

BESE METAL ve PLASTİK Ltd.Şti.
Organize Sanayi Bölgesi 6.Cad. No:19 KAYSERİ / TURKEY
T: +90 352 321 22 45 (Pbx)
F: +90 352 321 24 69
web: www.mywin.com.tr



Teknik Bilgiler ve Montaj Katalođu

PVC Window & Door Systems

**Profile Dimensions
Mounting Techniques**

Bu tanıtım materyali 1000 Adet olarak KOSGEB desteđi ile
10/03/2007 tarihinde hazırlanmıřtır/bastırılmıřtır.

This advertisement material is prepared/published as 1000
pieces in 10/03/2007 by the financial support of KOSGEB.





PVC Window & Door Systems

**Teknik Bilgiler
ve
Montaj Katalođu**

**Profile Dimensions
Mounting Techniques**



PVC Window & Door Systems

PVC Window & Door Systems

Hello,

We are witnessing the fact that the world is getting smaller each day with the increase in the knowledge of the sectors and the developments in innovations.

Bese Metal is operating at the construction sector since 1996 at its 4000m² enclosed area facilities equipped with latest technology.

Bese Metal has achieved “**UNCONDITIONAL CUSTOMER SATISFACTION**” without making a concession from **quality**, with its shelf profiles, inner and outer doorframes, joinery profiles, shutter gutters, support sheet profiles for PVC joinery and all kinds of open profile production. As a leading firm of the sector, **Bese Metal** is enjoying its well-earned pride for the level of quality and customer portfolio achieved.

In April 2005, **Bese Metal** started to produce PVC Window and Door systems, under the same structural organization and same principles with the brand of “**mywin**”, and is aiming to become one of the trademarks in this sector as well.

Bese Metal has achieved to combine reliability and aesthetics and to present these products to the customers with the help of its experienced staff and the right material choices for PVC profiles manufactured at European Standards under the “**mywin**” brand. Our objective is to become a worldwide brand, which heeds consumer satisfaction and embraces continuous innovations.

Respectfully,

mywin

Merhaba,

Sektörlerin sahip olduğu bilgi birikimi çoğaldıkça ve yenilikler geliştikçe dünyanın küçüldüğünü görmekteyiz.

Bese Metal, küçülen bu dünyada 1996 yılında 4000 m² kapalı alan üzerine en son teknolojiye sahip tesislerinde inşaat sektörüne hizmet vermektedir.

Bese Metal, raf profilleri, iç ve dış kapı kasaları, doğramalık profiller, kepenk olukları, PVC doğrama içi destek sacı profilleri ve her türlü açık profil imalatı ile kendine prensip edindiği **KALİTE** den taviz vermeyerek "**MUTLAK MÜŞTERİ MEMNUNİYETİ**" ni gerçekleştirmiştir. Sektörün öncülerinden olan **Bese Metal** ulaştığı bu kalite ve müşteri portföyü ile haklı gururunu yaşamaktadır.

Bese Metal, 2005 yılı Nisan ayı itibariyle aynı çatı altında, konusunda yabancı olmadığı ve hizmet ettiği PVC Pencere ve Kapı Sistemi sektörüne "**mywin**" markası adı altında PVC Pencere ve Kapı Sistemini aynı görüş ve prensiplerle sektöre yeni bir marka olma yolunda faaliyetlerine başlamıştır.

Bese Metal, "**mywin**" markası adı altında Avrupa standartlarında üretilen PVC profillerde, konusunda deneyimli kadrosu ve doğru malzeme seçiminde kendini geliştirerek, profillerde güveninirliğini ve estetiği bir araya getirmeyi başarmış ve kullanıcının beğenisine sunmuştur.

Amaç; sürekli kalite anlayışıyla son teknoloji ile kurduğu tesislerinde, daima kaliteli profil üretmek, rekabeti fiyatla değil kalitede aramak, sürekli yenilik anlayışını benimsemek ve tüketici memnuniyetine önem veren dünya çapında bir marka olmaktır.

Saygılarımızla,

mywin



PVC Window & Door Systems



www.mywin.com.tr



S-624

serisi profilleri

series profiles

S-624 KASA PROFİLİ
Ürün Kodu / Product Code: 624.11.00.0
S-624 FRAME PROFILE

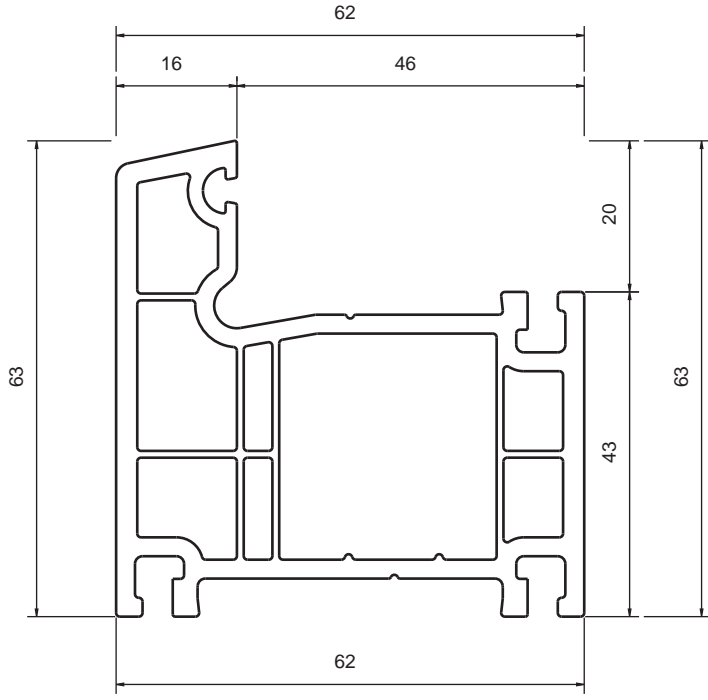

Ölçek 1/1 Scale



www.mywin.com.tr

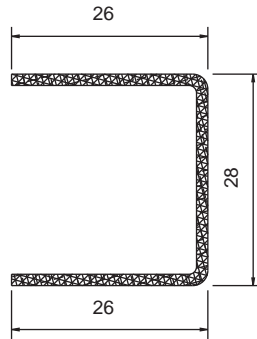

BESE METAL ve PLASTİK
teknik dökümanlarda değişiklik
yapma hakkını saklı tutar.
reserves the right to make any
modifications on technical
documents.

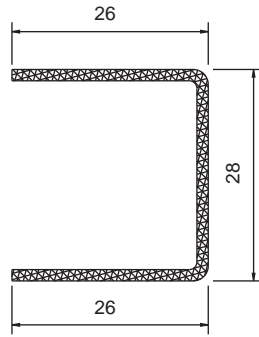
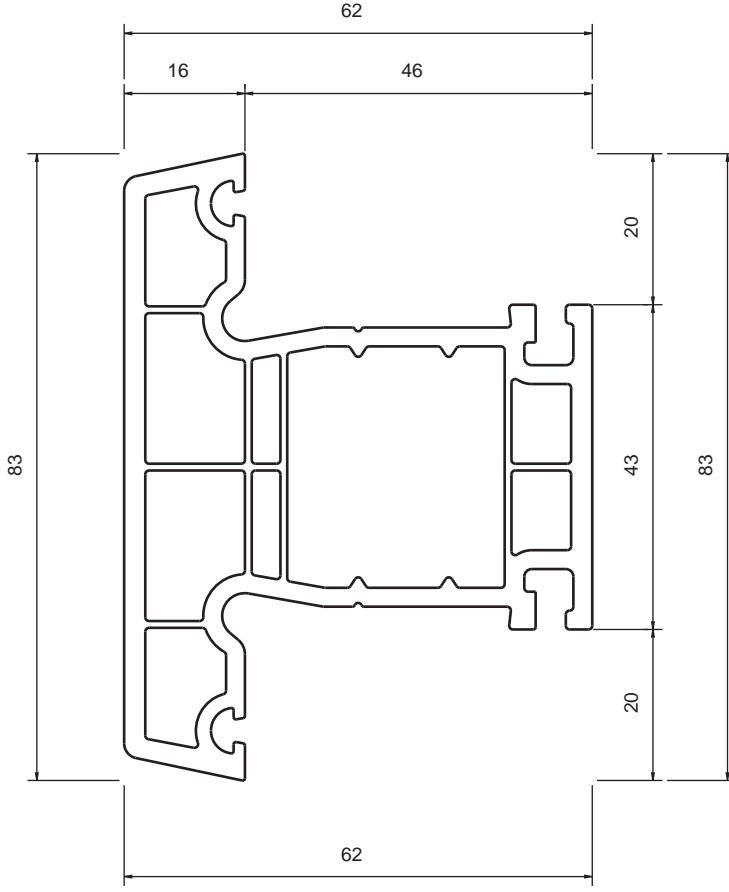

S-624 ORTA KAYIT PROFİLÝ
Ürün Kodu / Product Code: 624.21.00.0
S-624 MULLION PROFILE

Ölçek 1/1 Scale



www.mywin.com.tr

BESE METAL ve PLASTİK
teknik dökümanlarda değışiklik
yapma hakkını saklı tutar.
reserves the right to make any
modifications on technical
documents.

S-624 KANAT PROFİLİ
Ürün Kodu / Product Code: 624.31.00.0
S-624 SASH PROFILE

Ölçek 1/1 Scale



www.mywin.com.tr

BESE METAL ve PLASTİK
teknik dökümanlarda değişiklik
yapma hakkını saklı tutar.
reserves the right to make any
modifications on technical
documents.

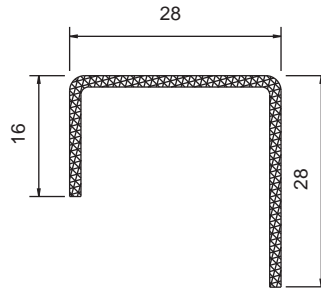
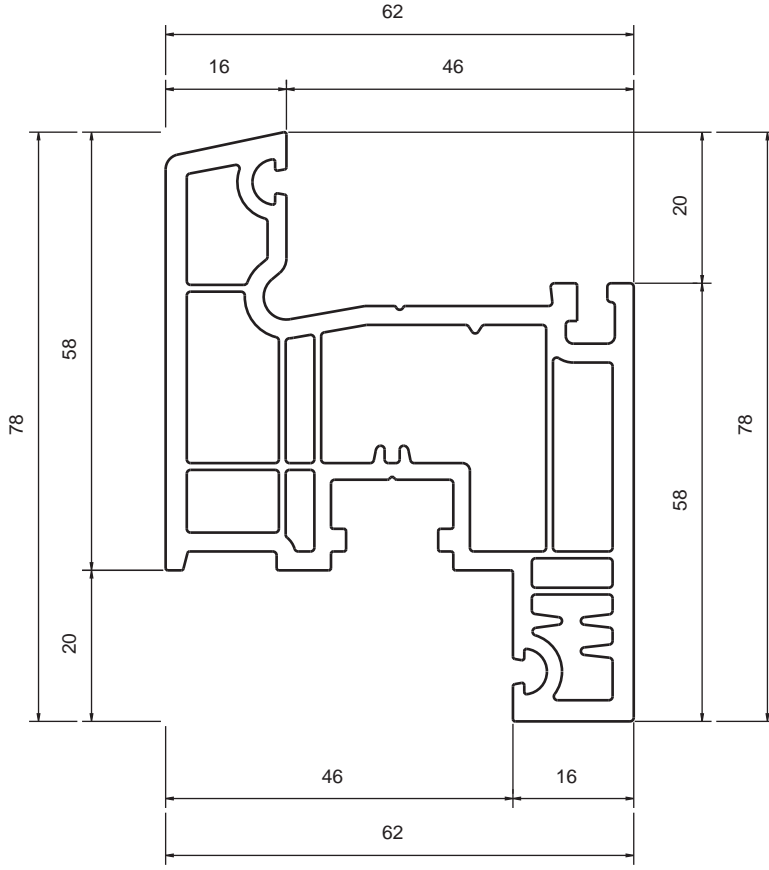

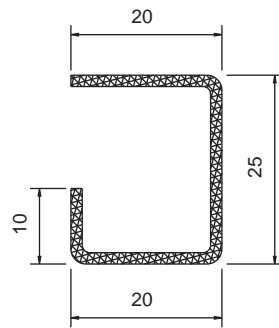
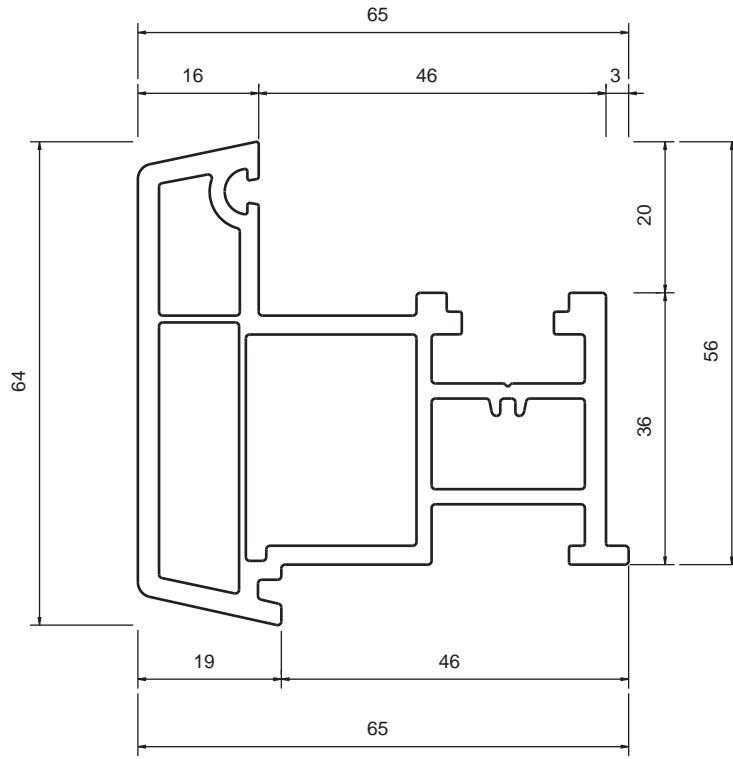

S-624 HAREKETLÝ ORTA KAYIT PROFÝLÝ
Ürün Kodu / Product Code: 624.61.00.0
S-624 MOVING MULLION PROFILE

Ölçek 1/1 Scale



www.mywin.com.tr

BESE METAL ve PLASTİK
teknik dökümanlarda değışiklik
yapma hakkını saklı tutar.
reserves the right to make any
modifications on technical
documents.

S-624 İÇE AÇILIM KAPI KANAT PROFİLİ

Ürün Kodu / Product Code: 624.41.00.0

S-624 IN SIDE DOOR SASH PROFILE

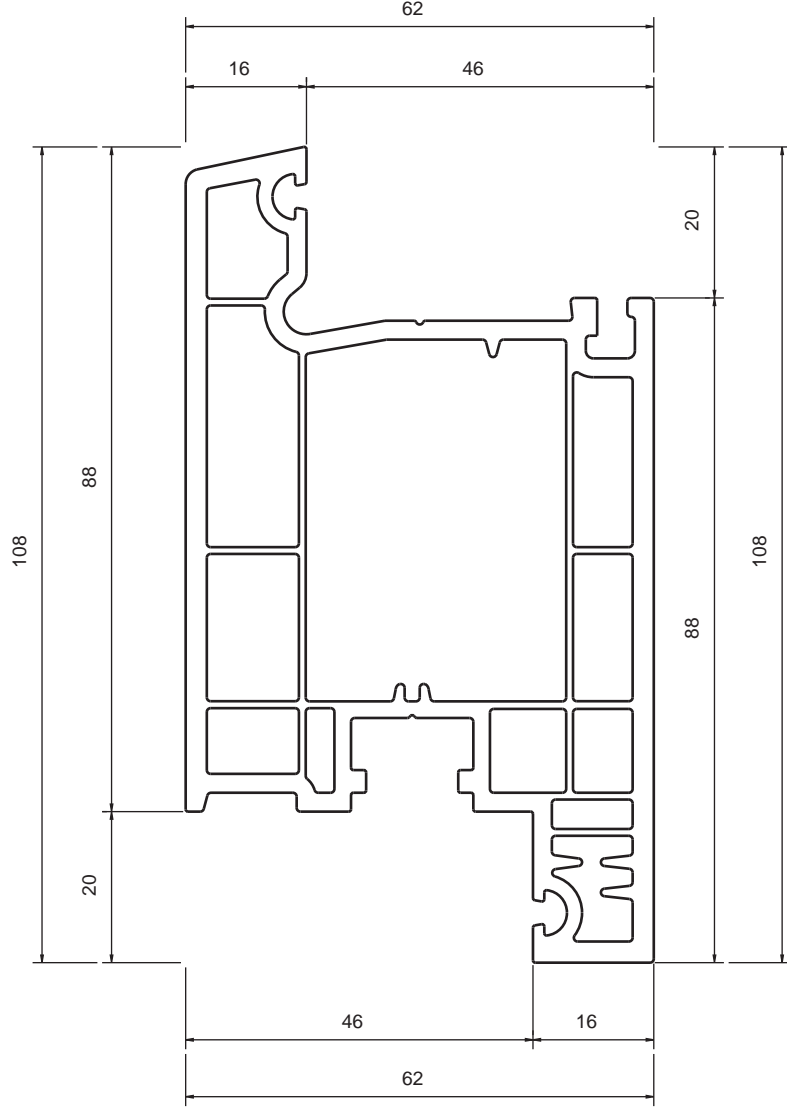

Ölçek 1/1 Scale



www.mywin.com.tr

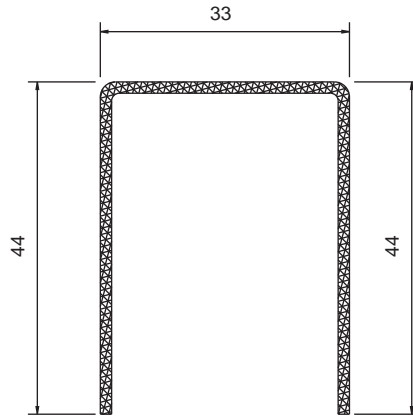

BESE METAL ve PLASTİK
teknik dokümanlarda değişiklik
yapma hakkını saklı tutar.
reserves the right to make any
modifications on technical
documents.

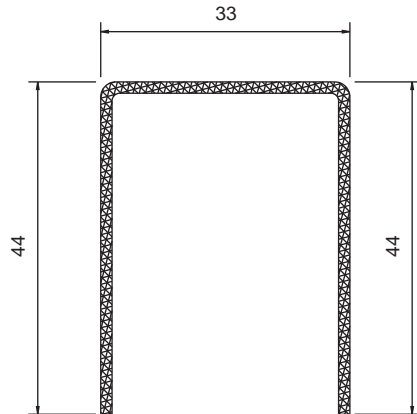
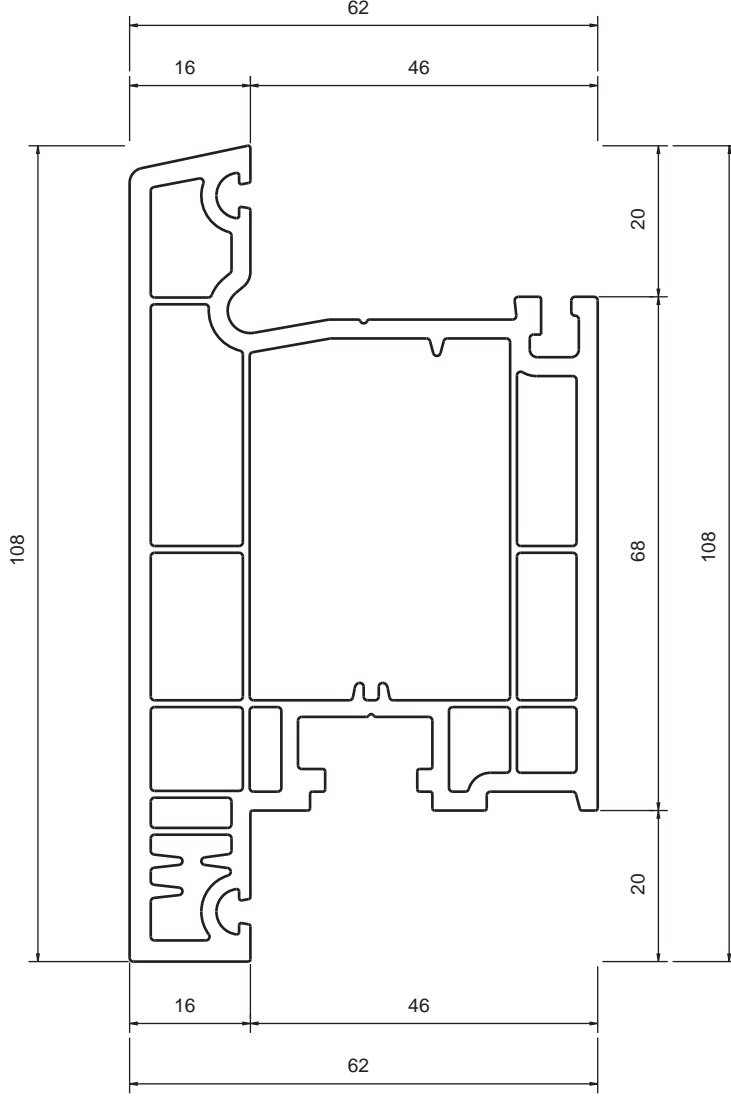

S-624 DİPA AÇILIM KAPI KANAT PROFİLİ
Ürün Kodu / Product Code: 624.42.00.0
S-624 OUT SIDE DOOR SASH PROFILE

Ölçek 1/1 Scale



www.mywin.com.tr

BESE METAL ve PLASTİK
teknik dökümanlarda değişiklik
yapma hakkını saklı tutar.
reserves the right to make any
modifications on technical
documents.

S-624 4mm TEK CAM ÇİTASI
Ürün Kodu / Product Code: 624.51.00.0
S-624 SINGLE GLASS BEAT 4mm

Ölçek 1/1 Scale



www.mywin.com.tr

BESE METAL ve PLASTİK
teknik dokümanlarda değişiklik
yapma hakkını saklı tutar.
reserves the right to make any
modifications on technical
documents.

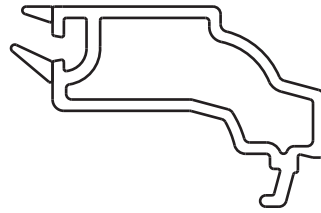
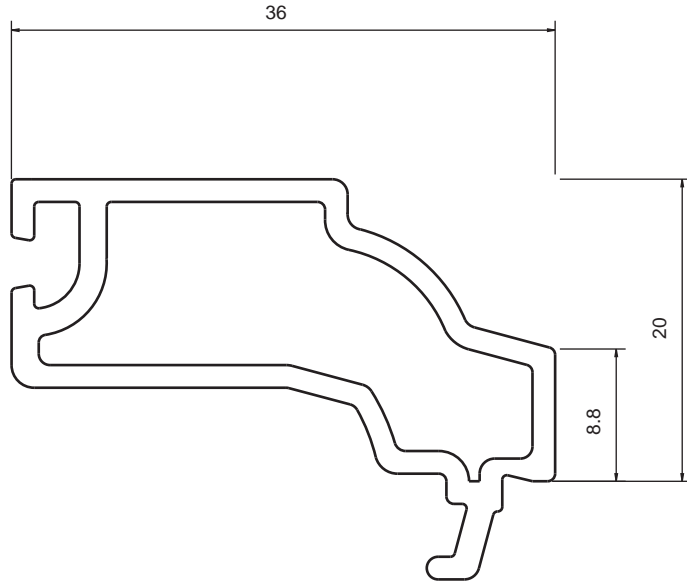
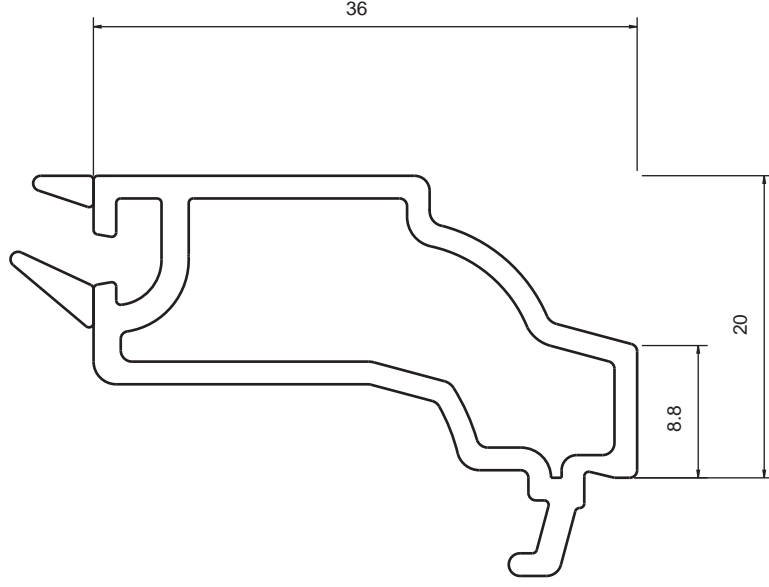

Ölçek 1/1 Scale

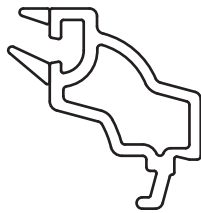
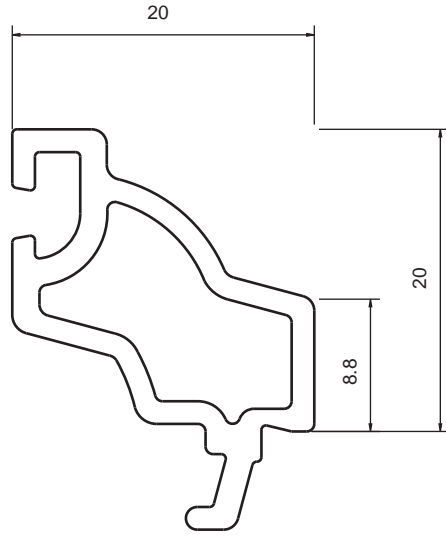
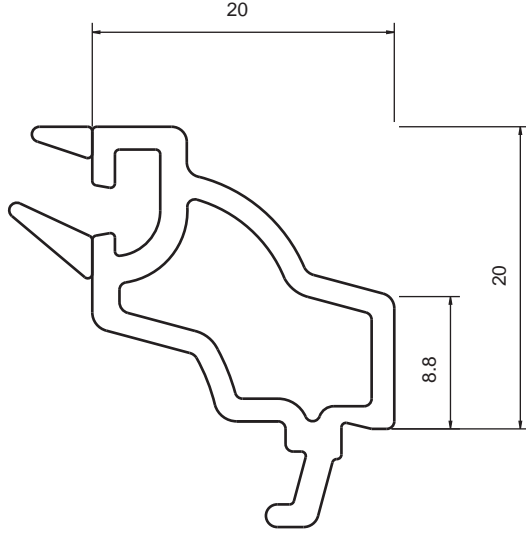

Ölçek 1/1 Scale

S-624 20mm ISICAM ÇİTASI
Ürün Kodu / Product Code: 624.52.00.0
S-624 DOUBLE GLASS BEAT 20mm

Ölçek 1/1 Scale



www.mywin.com.tr

BESE METAL ve PLASTİK
teknik dökümanlarda değişiklik
yapma hakkını saklı tutar.
reserves the right to make any
modifications on technical
documents.

S-624 24mm ISICAM ÇITASI
Ürün Kodu / Product Code: 624.53.00.0
S-624 DOUBLE GLASS BEAT 24mm

Ölçek 1/1 Scale



www.mywin.com.tr

BESE METAL ve PLASTİK
teknik dökümanlarda değişiklik
yapma hakkını saklı tutar.
reserves the right to make any
modifications on technical
documents.

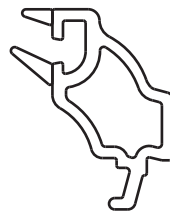
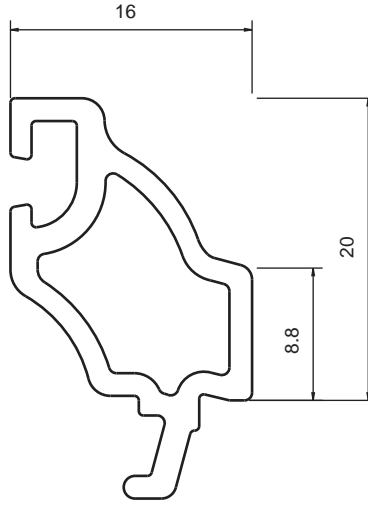
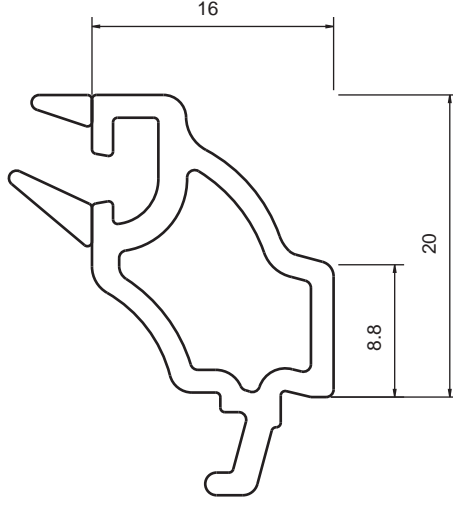

Ölçek 1/1 Scale

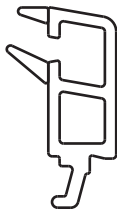
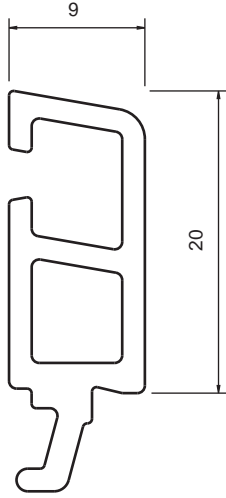
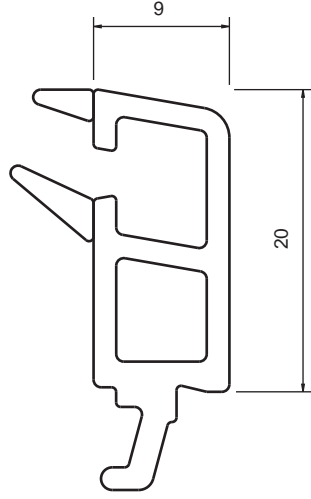

Ölçek 1/1 Scale

S-624 30mm ÜÇLÜ ISICAM ÇITASI
Ürün Kodu / Product Code: 624.54.00.0
S-624 TRIPLE GLASS BEAT 30mm

Ölçek 1/1 Scale

mywin[®]
PVC Window & Door Systems

www.mywin.com.tr

BESE METAL ve PLASTİK
teknik dökümanlarda değişiklik
yapma hakkını saklı tutar.
reserves the right to make any
modifications on technical
documents.

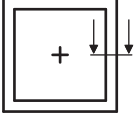

S-624 KASA & 4mm TEK CAM ÇITASI BİRLEŞİM DETAYI

S-624 FRAME & SINGLE GLASS BEAT 4mm APPLICATION DETAIL

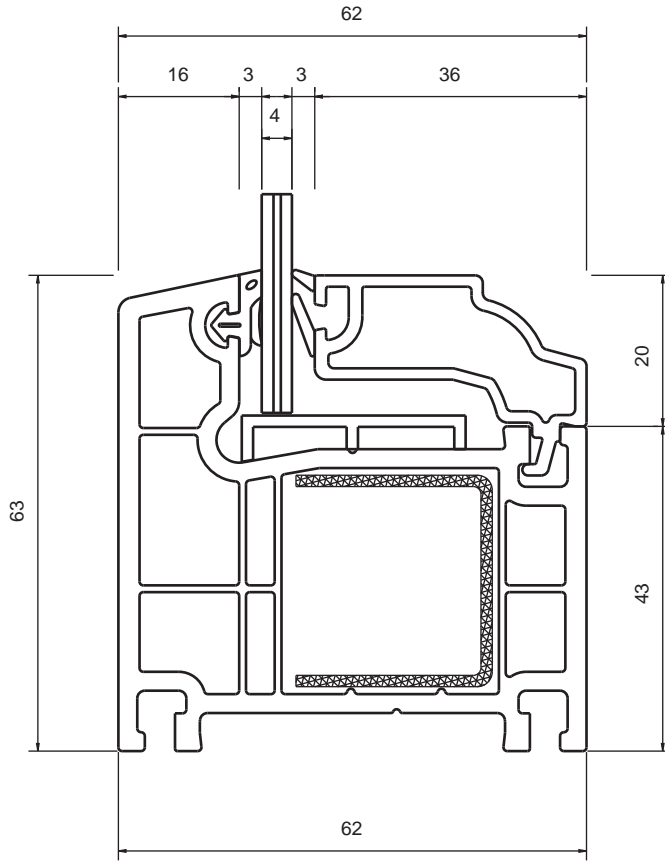

Ölçek 1/1 Scale



www.mywin.com.tr

BESE METAL ve PLASTİK
teknik dokümanlarda değişiklik
yapma hakkını saklı tutar.
reserves the right to make any
modifications on technical
documents.

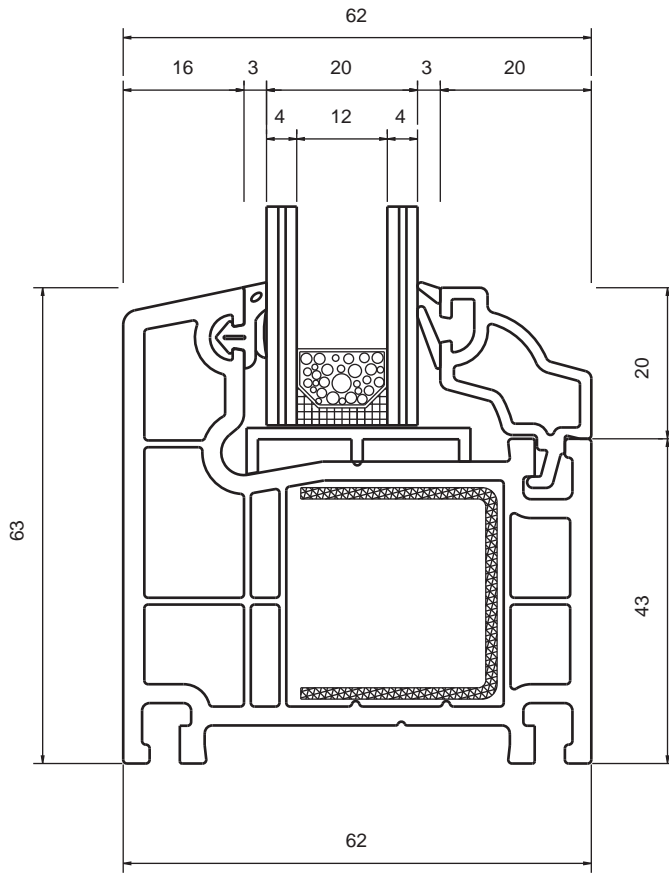
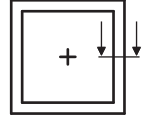

S-624 KASA & 20mm ISICAM CAM ÇITASI BİRLEŞİM DETAYI
S-624 FRAME & DOUBLE GLASS BEAT 20mm APPLICATION DETAIL

Ölçek 1/1 Scale



www.mywin.com.tr

BESE METAL ve PLASTİK
teknik dökümanlarda değişiklik
yapma hakkını saklı tutar.
reserves the right to make any
modifications on technical
documents.

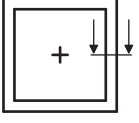

S-624 KASA & 24mm ISICAM CAM ÇITASI BİRLEŞİM DETAYI
S-624 FRAME & DOUBLE GLASS BEAT 24mm APPLICATION DETAIL

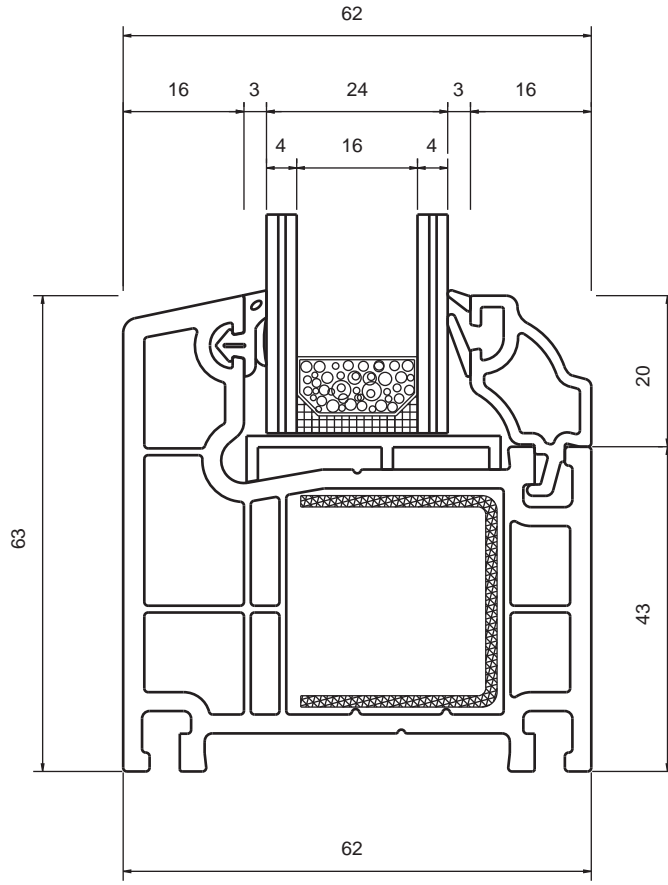

Ölçek 1/1 Scale



www.mywin.com.tr

BESE METAL ve PLASTİK
teknik dökümanlarda değişiklik
yapma hakkını saklı tutar.
reserves the right to make any
modifications on technical
documents.

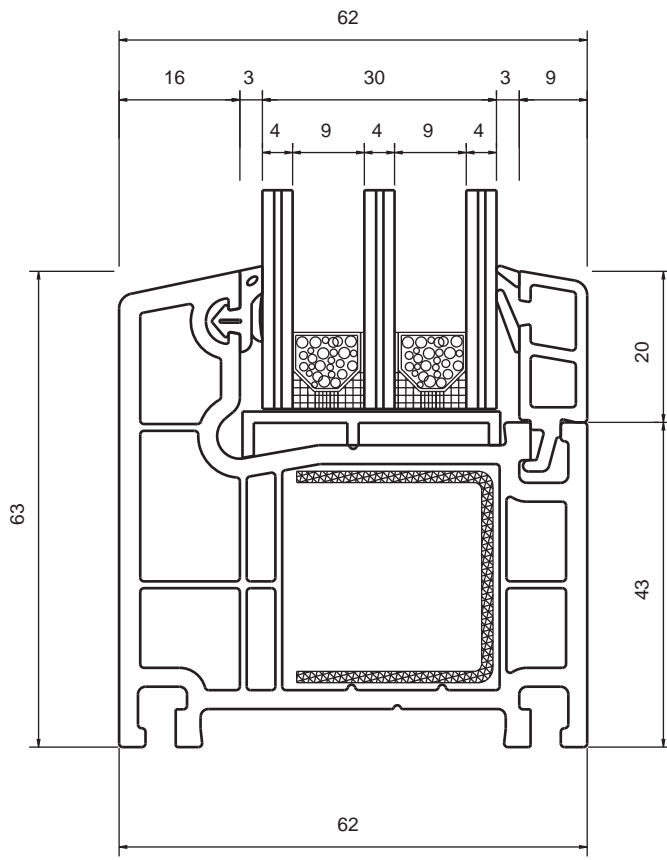
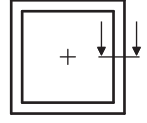

S-624 KASA & 30mm ÜÇLÜ ISICAM CAM ÇITASI BİRLEŞİM DETAYI
S-624 FRAME & TRIPLE GLASS BEAT 30mm APPLICATION DETAIL

Ölçek 1/1 Scale



www.mywin.com.tr

BESE METAL ve PLASTİK
teknik dökümanlarda değişiklik
yapma hakkını saklı tutar.
reserves the right to make any
modifications on technical
documents.

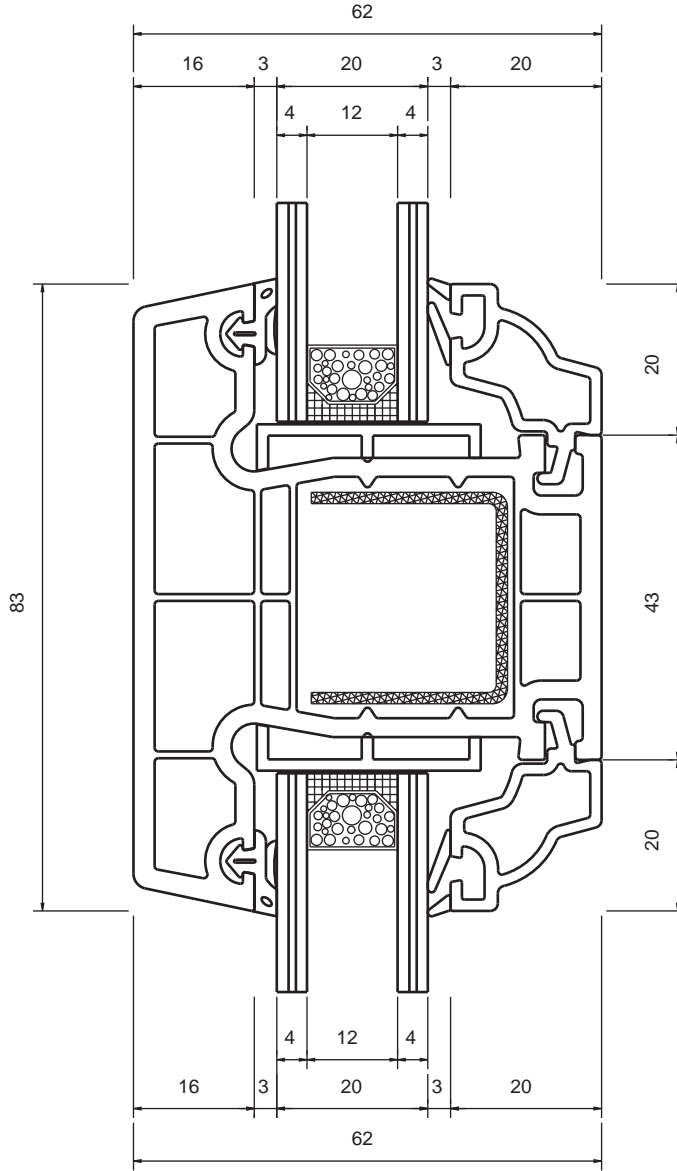
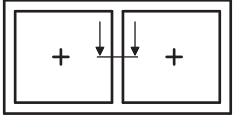

S-624 ORTA KAYIT & 20mm ISICAM ÇITASI BİRLEŞİM DETAYI

S-624 MULLION & DOUBLE GLASS BEAT 20mm APPLICATION DETAIL

Ölçek 1/1 Scale



www.mywin.com.tr

BESE METAL ve PLASTİK
teknik dökümanlarda değişiklik
yapma hakkını saklı tutar.
reserves the right to make any
modifications on technical
documents.

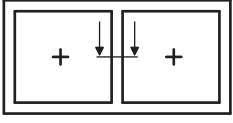

S-624 ORTA KAYIT & 24mm ISICAM ÇITASI BİRLEŞİM DETAYI

S-624 MULLION & DOUBLE GLASS BEAT 24mm APPLICATION DETAIL

Ölçek 1/1 Scale



www.mywin.com.tr

BESE METAL ve PLASTİK
teknik dokümanlarda değişiklik
yapma hakkını saklı tutar.
reserves the right to make any
modifications on technical
documents.

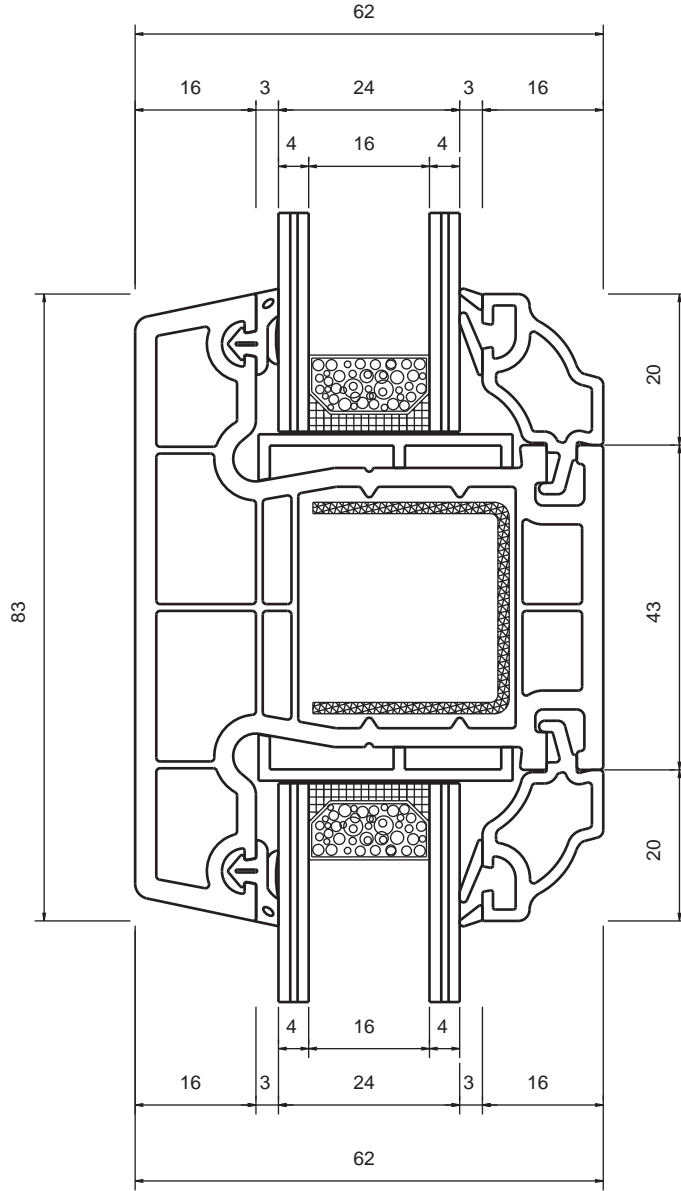

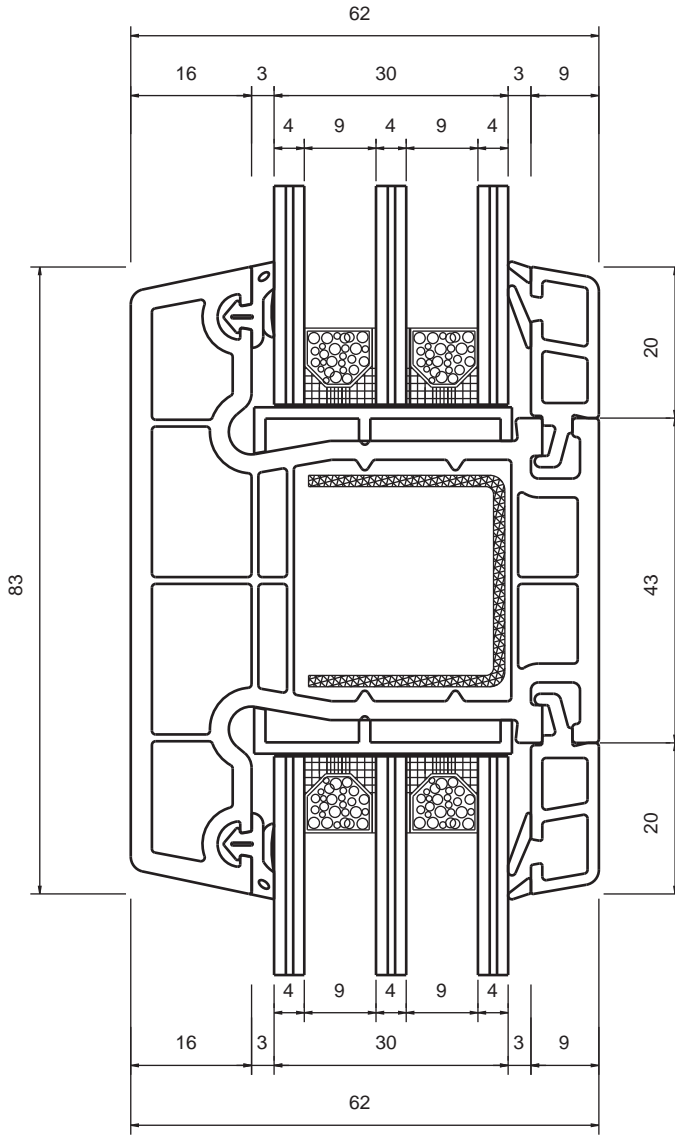
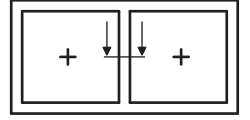

**S-624 ORTA KAYIT & 30mm ÜÇLÜ ISICAM ÇITASI
BİRLEŞİM DETAYI**
S-624 MULLION & TRIPLE GLASS BEAT 30mm APPLICATION DETAIL

Ölçek 1/1 Scale



www.mywin.com.tr

BESE METAL ve PLASTİK
teknik dökümanlarda değişiklik
yapma hakkını saklı tutar.
reserves the right to make any
modifications on technical
documents.

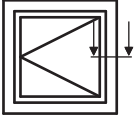

S-624 KASA & S-624 KANAT BİRLEŞİM DETAYI

S-624 FRAME & S-624 SASH APPLICATION DETAIL

Ölçek 1/1 Scale

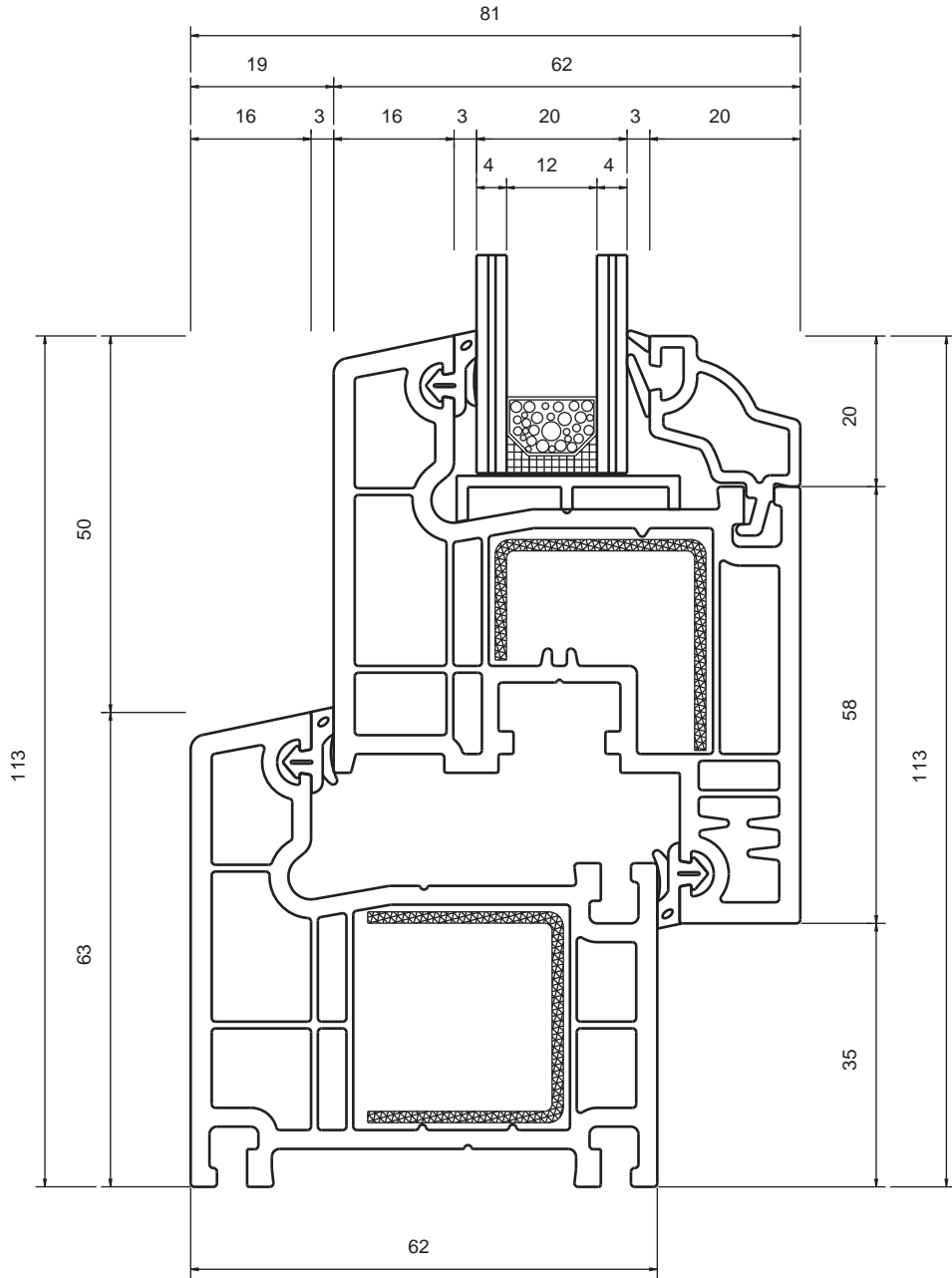

www.mywin.com.tr

BESE METAL ve PLASTİK
teknik dokümanlarda değişiklik
yapma hakkını saklı tutar.
reserves the right to make any
modifications on technical
documents.

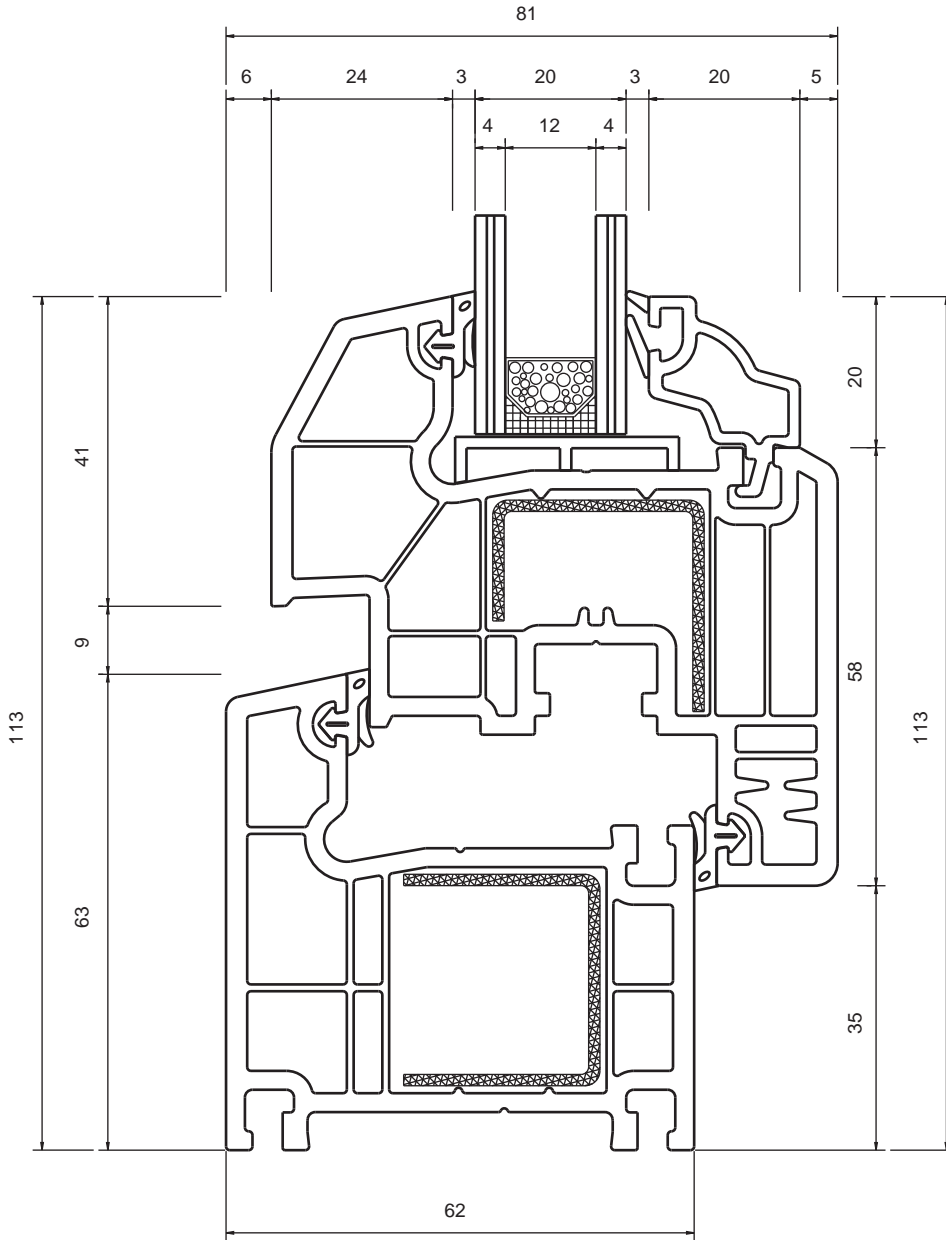
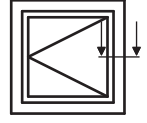

S-624 KASA & S-705 DAMLALIKLI KANAT BİRLEŞİM DETAYI

S-624 FRAME & S-705 DRAINER SASH APPLICATION DETAIL

Ölçek 1/1 Scale



www.mywin.com.tr

BESE METAL ve PLASTİK
teknik dökümanlarda değişiklik
yapma hakkını saklı tutar.
reserves the right to make any
modifications on technical
documents.

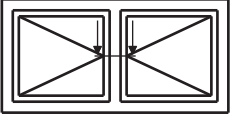

**S-624 KANAT & S-624 ORTA KAYIT & S-624 KANAT
BİRLEŞİM DETAYI**
S-624 SASH & S-624 MULLION & S-624 SASH APPLICATION DETAIL

Ölçek 1/1 Scale



www.mywin.com.tr

BESE METAL ve PLASTİK
teknik dokümanlarda değişiklik
yapma hakkını saklı tutar.
reserves the right to make any
modifications on technical
documents.

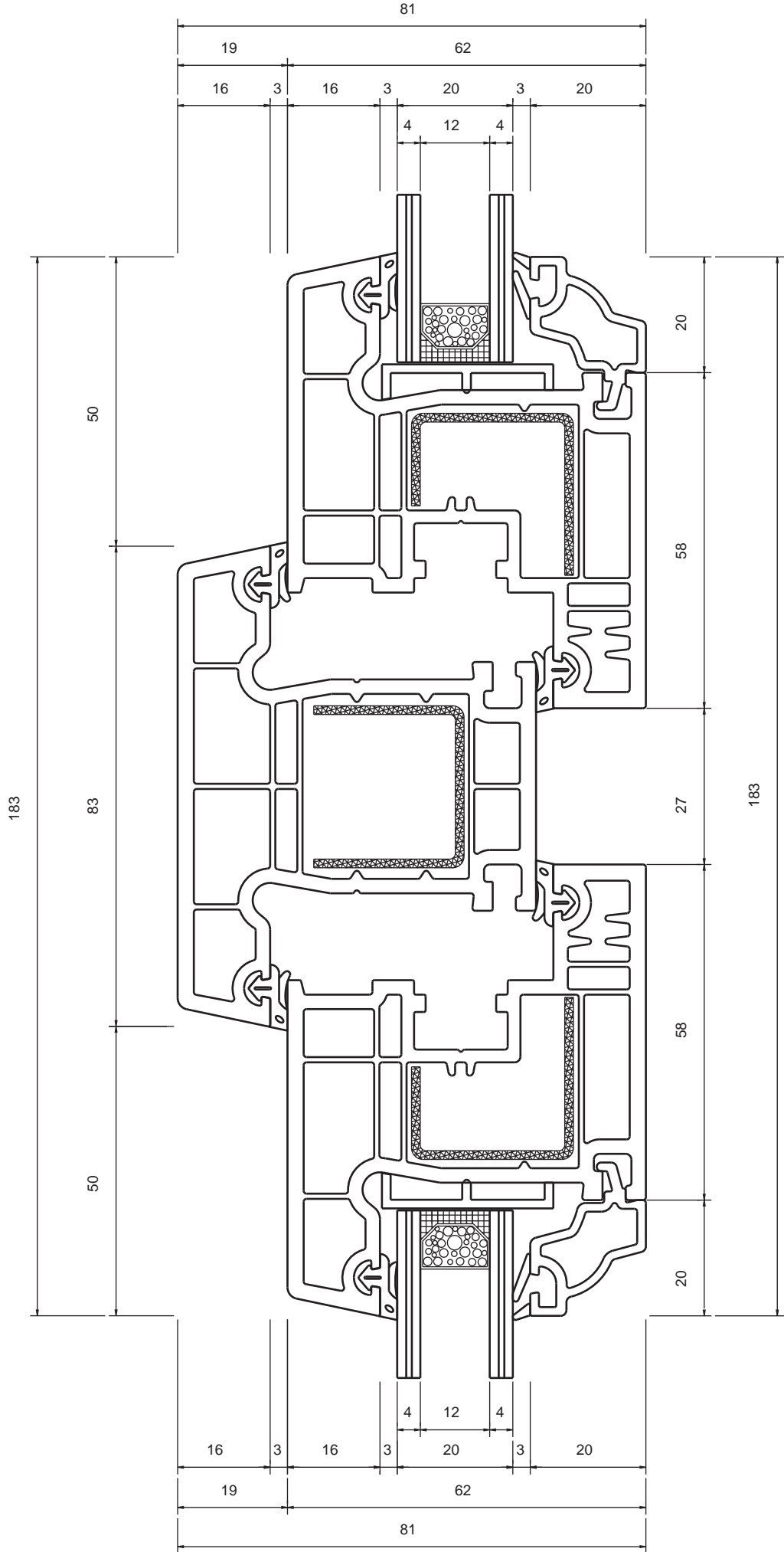

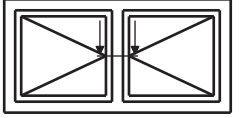
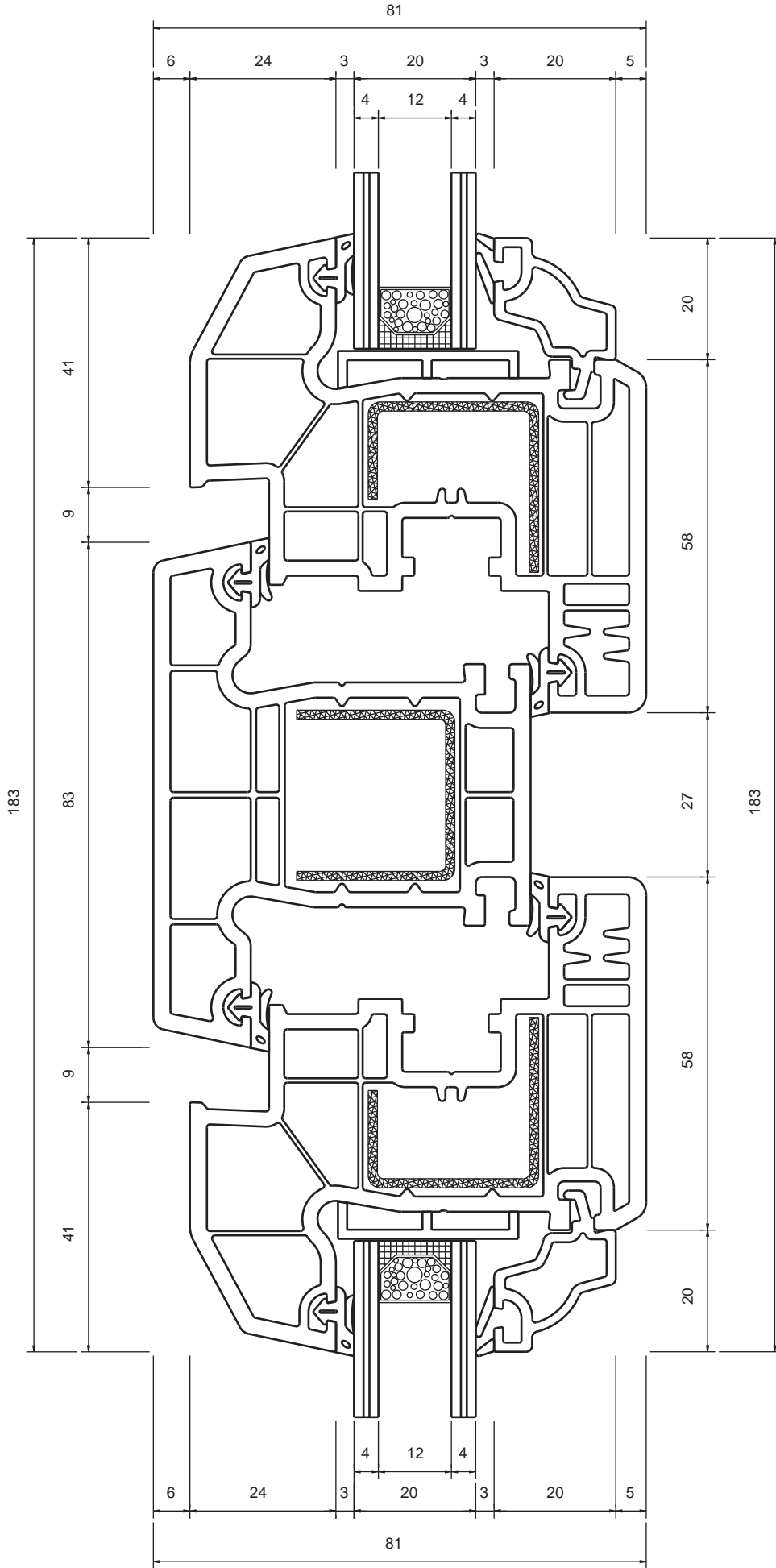

**S-705 DAMLALIKLI KANAT & S-624 ORTA KAYIT &
S-705 DAMLALIKLI KANAT BİRLEŞİM DETAYI
S-705 DRAINER SASH & S-624 MULLION & S-705 DRAINER SASH APPLICATION DETAIL**

Ölçek 1/1 Scale



www.mywin.com.tr

BESE METAL ve PLASTİK
teknik dökümanlarda değişiklik
yapma hakkını saklı tutar.
reserves the right to make any
modifications on technical
documents.

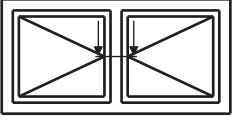

**S-624 KANAT & S-624 HAREKETLÝ ORTA KAYIT &
S-624 KANAT BÝRLEÞM DETAYI**

S-624 SASH & S-624 MOVING MULLION & S-624 SASH APPLICATION DETAIL

Ölçek 1/1 Scale



www.mywin.com.tr

BESE METAL ve PLASTİK
teknik dökümanlarda deęişiklik
yapma hakkını saklı tutar.
reserves the right to make any
modifications on technical
documents.

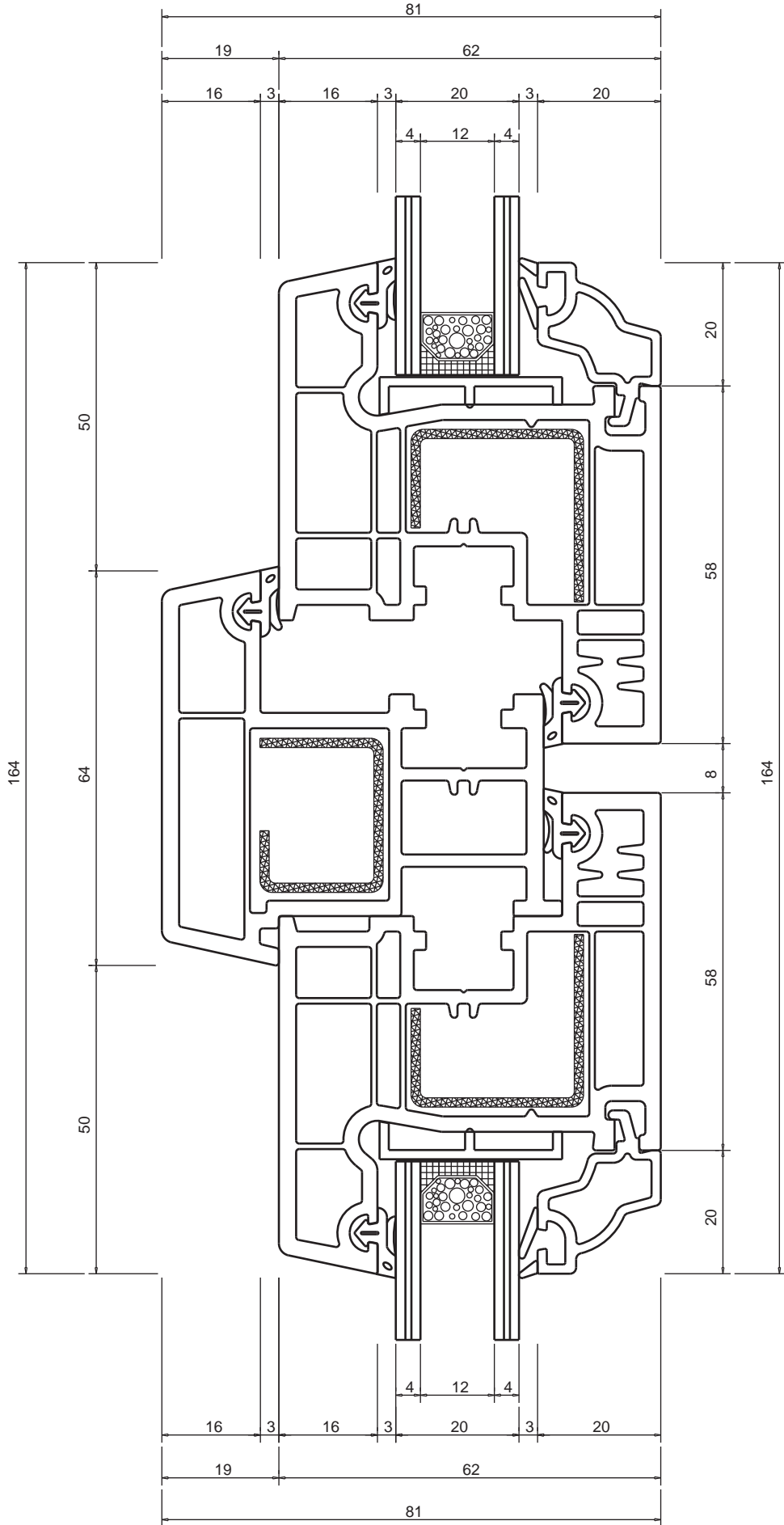

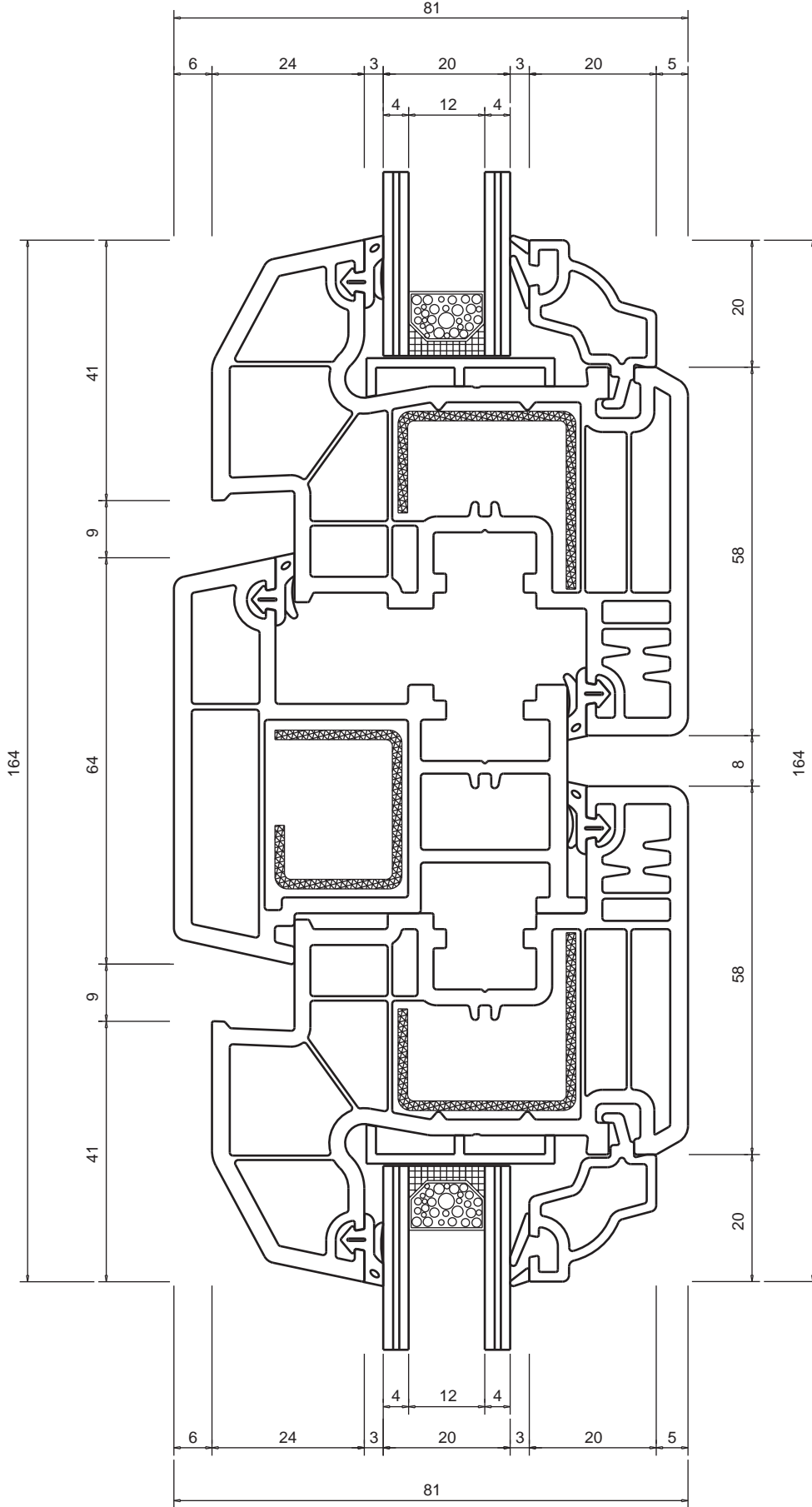
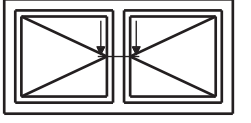

S-705 DAMLALIKLI KANAT & HAREKETLİ ORTA KAYIT &
S-705 DAMLALIKLI KANAT - BİRLEPİM DETAYI
S-705 DRAINER SASH & MOVING MULLION & S-705 DRAINER SASH
APPLICATION DETAIL

Ölçek 1/1 Scale



www.mywin.com.tr

BESE METAL ve PLASTİK
teknik dökümanlarda değışiklik
yapma hakkını saklı tutar.
reserves the right to make any
modifications on technical
documents.

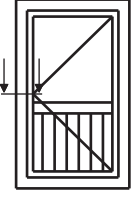

**S-624 KASA & S-624 İÇE AÇILIM KAPI KANAT
BİRLEŞİM DETAYI**
S-624 FRAME & S-624 IN SIDE DOOR SASH APPLICATION DETAIL

Ölçek 1/1 Scale

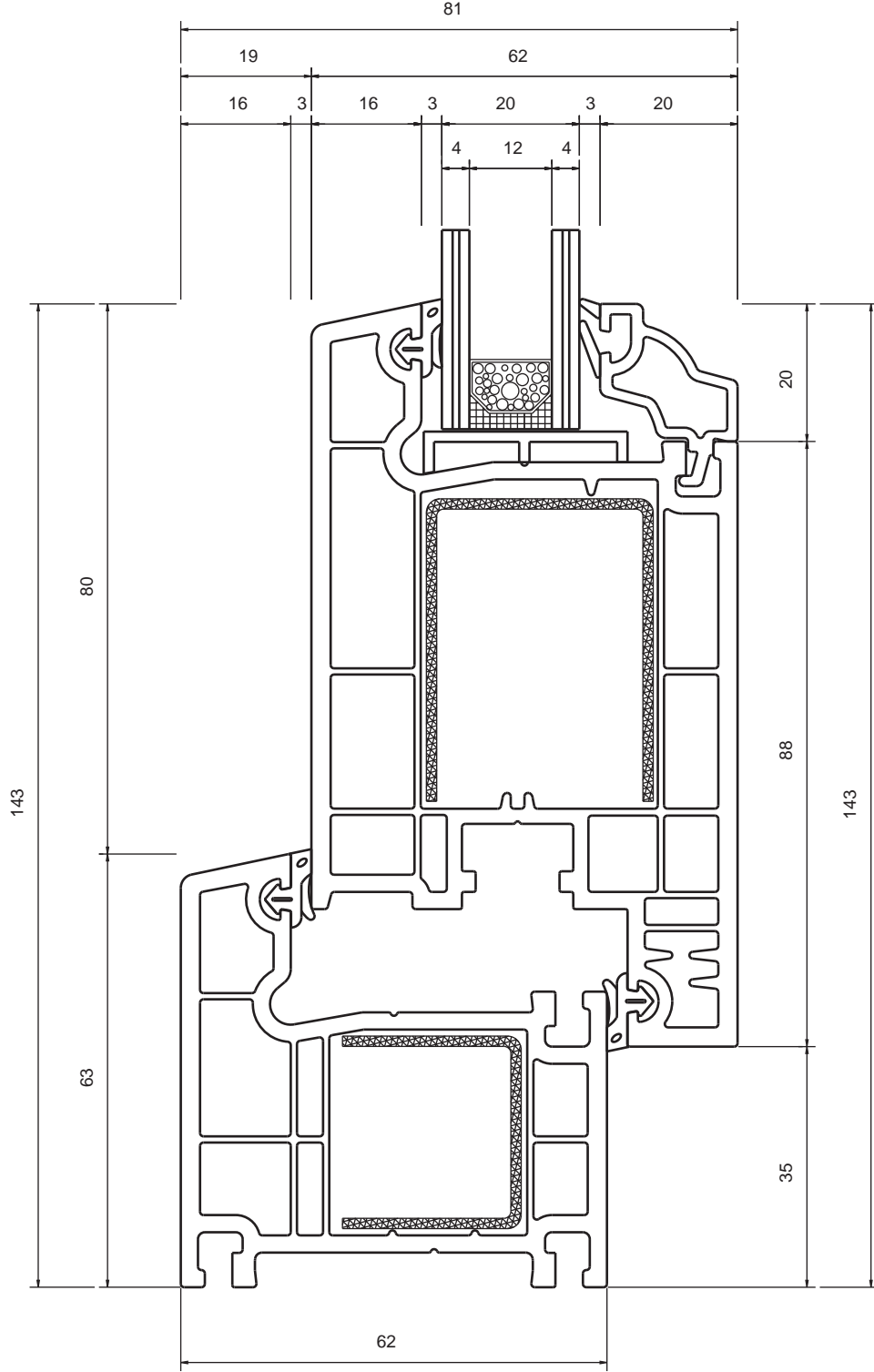

www.mywin.com.tr

BESE METAL ve PLASTİK
teknik dökümanlarda değişiklik
yapma hakkını saklı tutar.
reserves the right to make any
modifications on technical
documents.

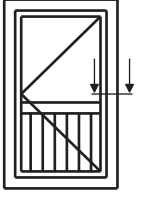
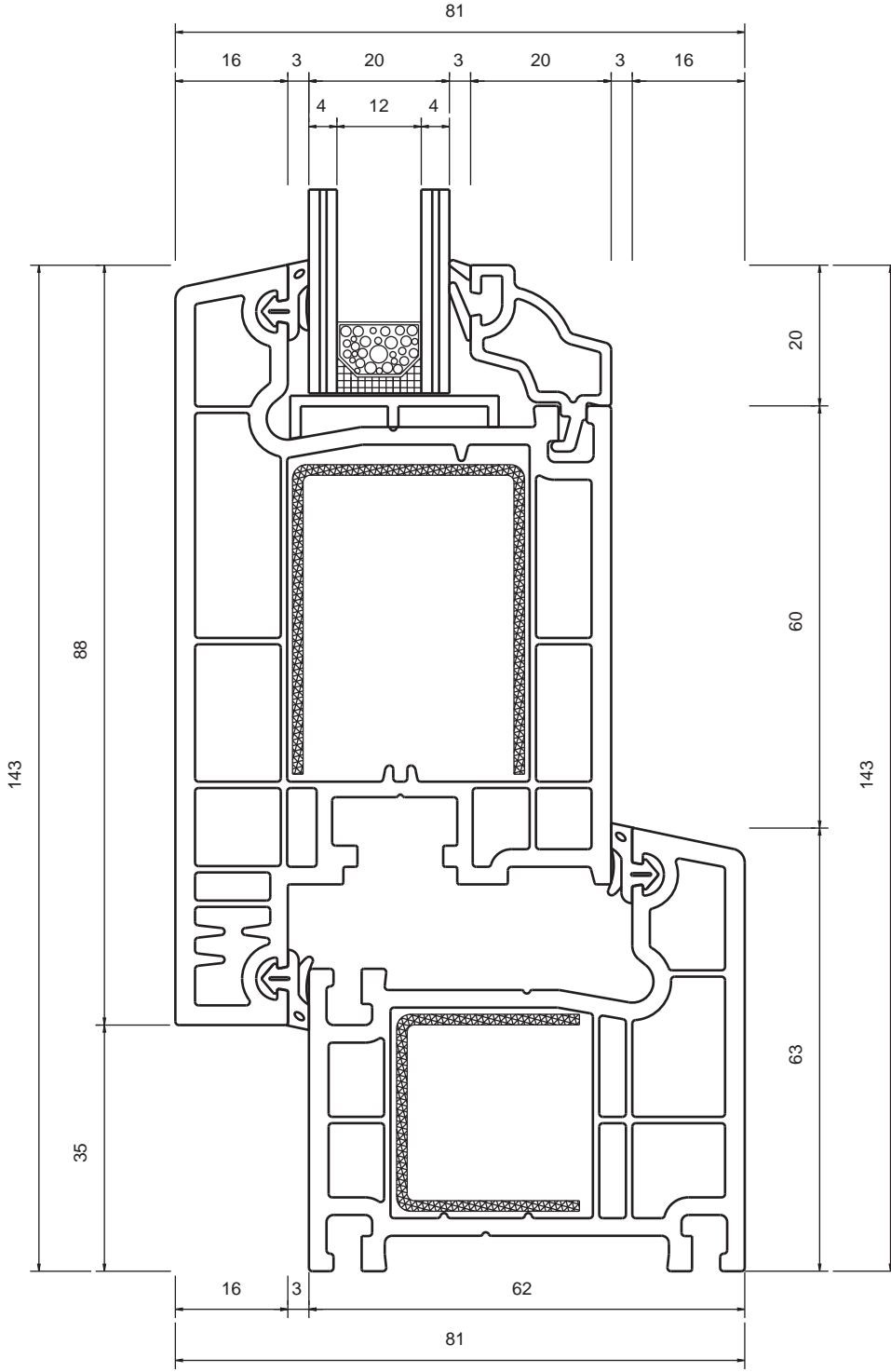

**S-624 KASA & S-624 DİPA AÇILIM KAPI KANAT
BİRLEŞİM DETAYI**
S-624 FRAME & S-624 OUT SIDE DOOR SASH APPLICATION DETAIL

Ölçek 1/1 Scale



www.mywin.com.tr

BESE METAL ve PLASTİK
teknik dökümanlarda değişiklik
yapma hakkını saklı tutar.
reserves the right to make any
modifications on technical
documents.

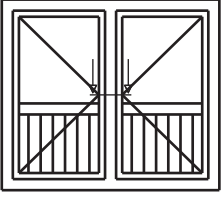

**S-624 İÇE AÇILIM KAPI KANAT & S-624 ORTA KAYIT &
S-624 İÇE AÇILIM KAPI KANAT BİRLEŞİM DETAYI**
S-624 IN SIDE DOOR SASH & S-624 MULLION & S-624 IN SIDE DOOR SASH
APPLICATION DETAIL

Ölçek 1/1 Scale



www.mywin.com.tr

BESE METAL ve PLASTİK
teknik dokümanlarda değişiklik
yapma hakkını saklı tutar.
reserves the right to make any
modifications on technical
documents.

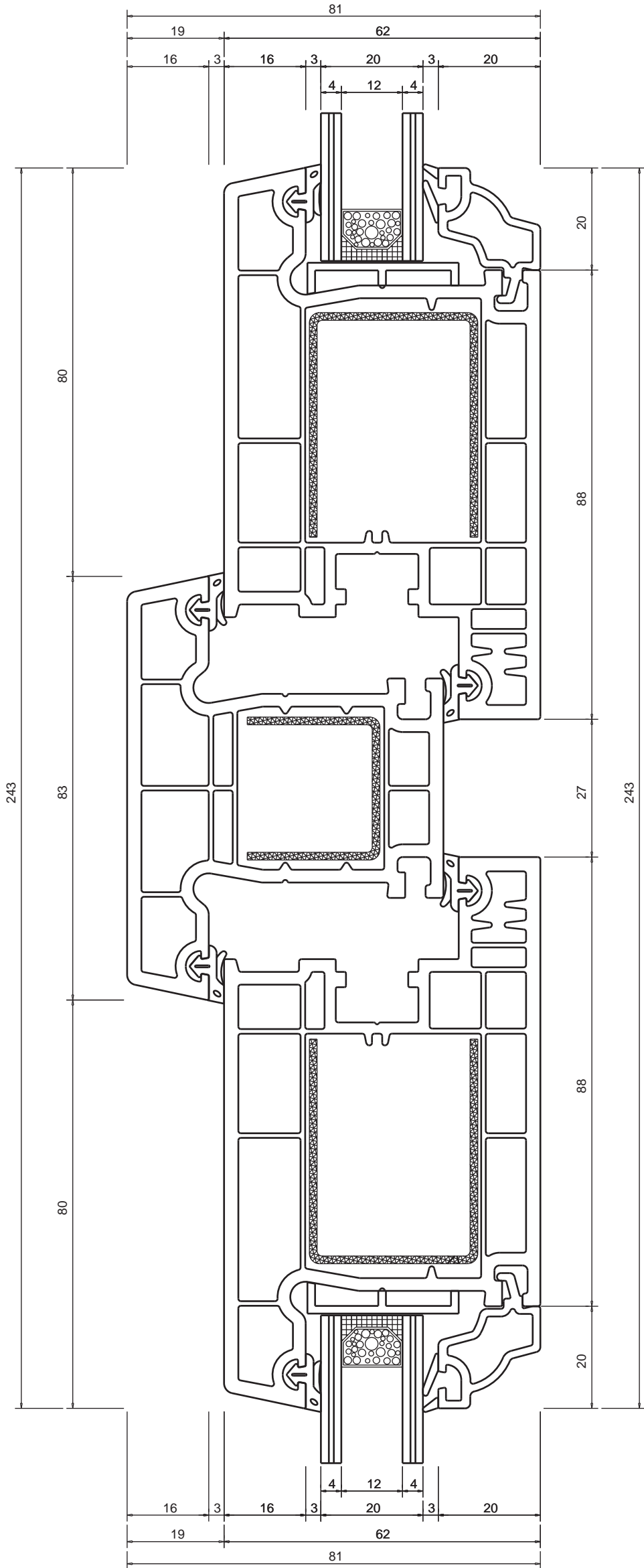

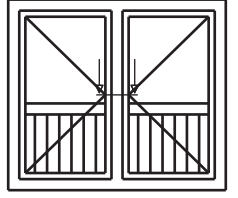
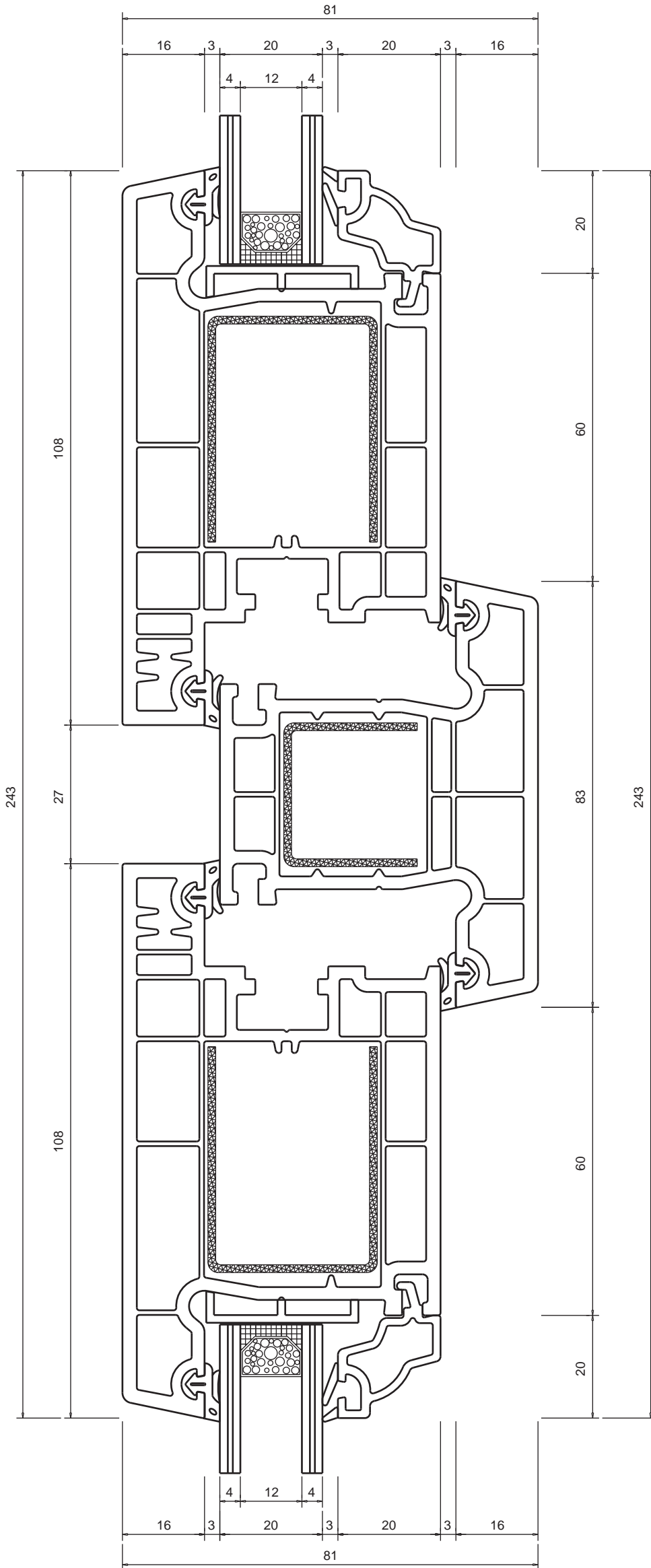

**S-624 DİPA AÇILIM KAPI KANAT & S-624 ORTA KAYIT &
S-624 DİPA AÇILIM KAPI KANAT BİRLEŞİM DETAYI**
S-624 OUT SIDE DOOR SASH & MULLION & S-624 OUT SIDE DOOR SASH
APPLICATION DETAIL

Ölçek 1/1 Scale



www.mywin.com.tr

BESE METAL ve PLASTİK
teknik dökümanlarda değişiklik
yapma hakkını saklı tutar.
reserves the right to make any
modifications on technical
documents.

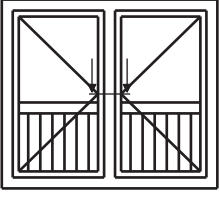

**S-624 İÇE AÇILIM KAPI KANAT & S-624 HAREKETLİ ORTA KAYIT &
S-624 İÇE AÇILIM KAPI KANAT BİRLEŞİM DETAYI
S-624 IN SIDE DOOR SASH & S-624 MOVING MULLION &
S-624 IN SIDE DOOR SASH APPLICATION DETAIL**

Ölçek 1/1 Scale



www.mywin.com.tr

BESE METAL ve PLASTİK
teknik dökümanlarda değişiklik
yapma hakkını saklı tutar.
reserves the right to make any
modifications on technical
documents.

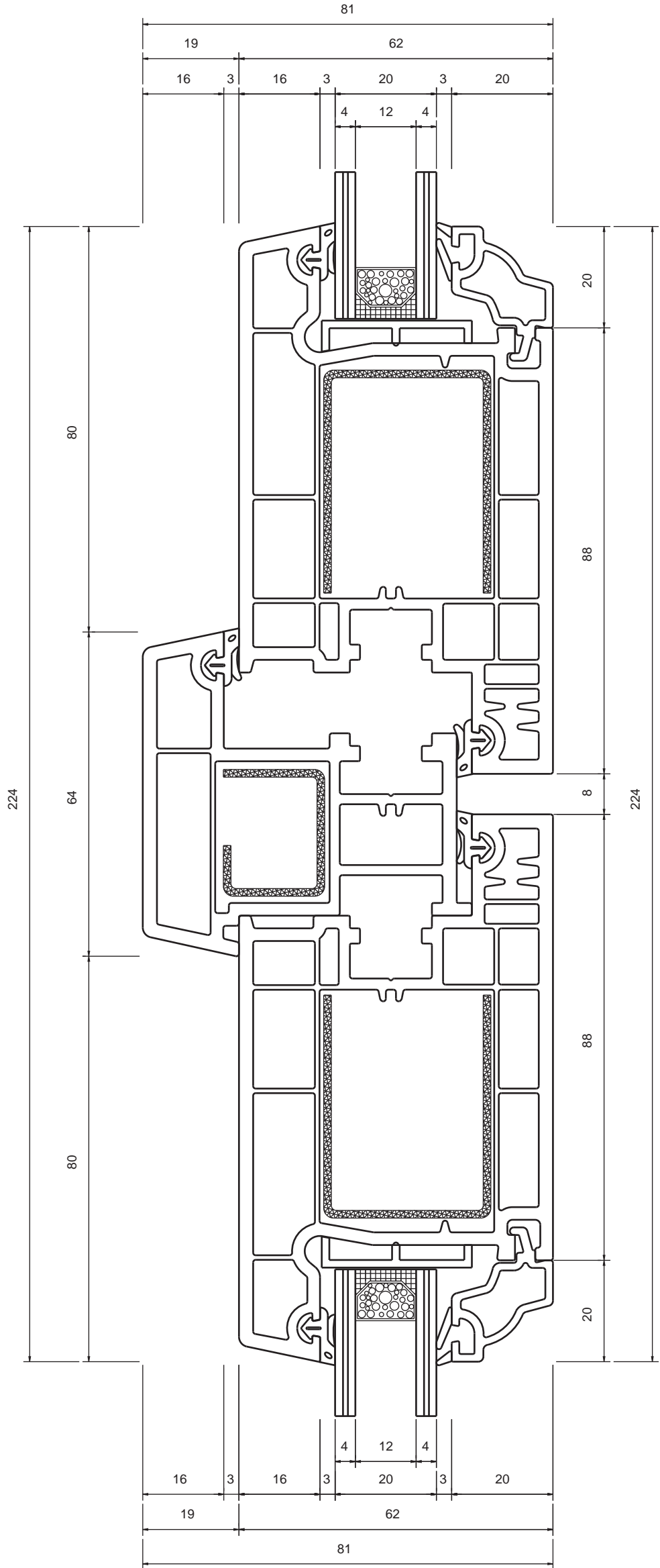

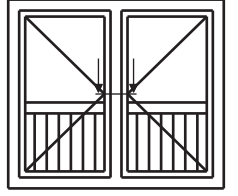
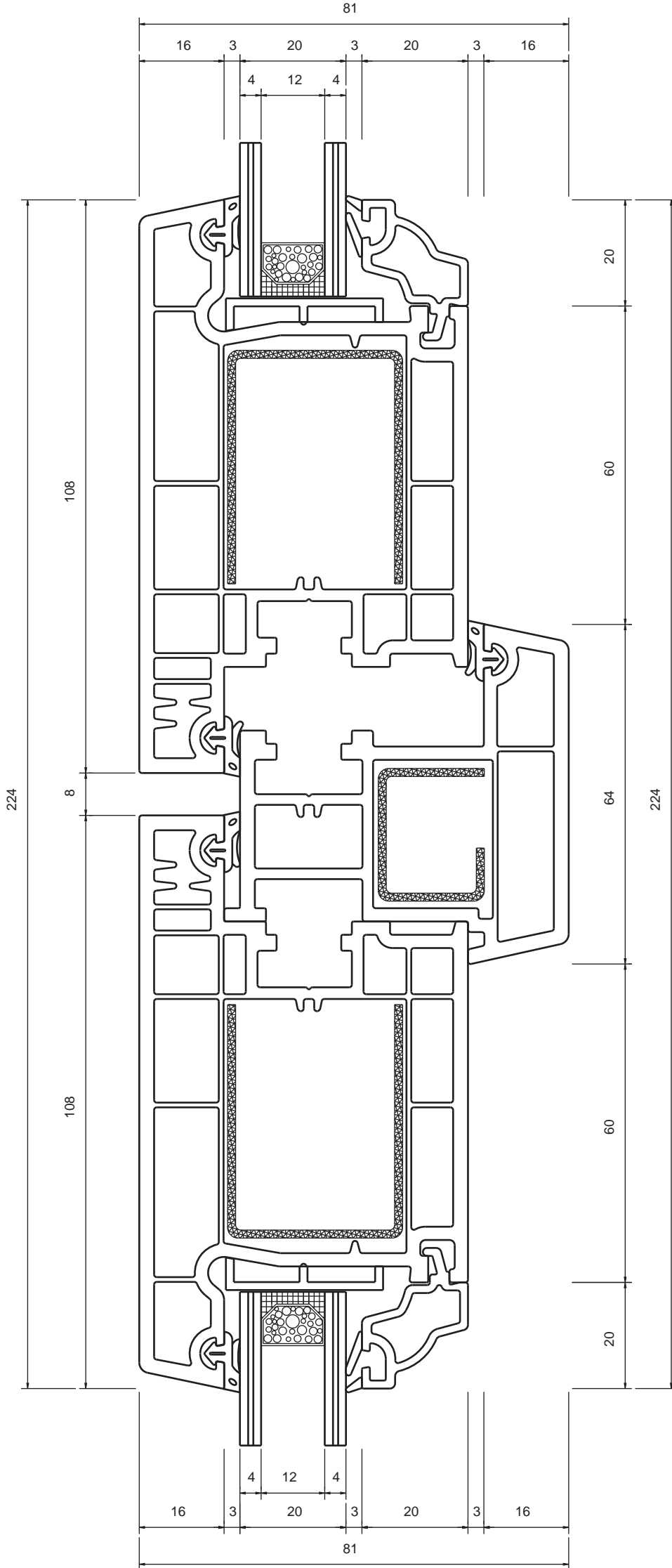

S-624 DİPA AÇILIM KAPI KANAT & S-624 HAREKETLİ ORTA KAYIT &
S-624 DİPA AÇILIM KAPI KANAT BİRLEŞİM DETAYI
S-624 OUT SIDE DOOR SASH & S-624 MOVING MULLION &
S-624 OUT SIDE DOOR SASH APPLICATION DETAIL

Ölçek 1/1 Scale

mywin[®]
PVC Window & Door Systems

www.mywin.com.tr

BESE METAL ve PLASTİK
teknik dökümanlarda değişiklik
yapma hakkını saklı tutar.
reserves the right to make any
modifications on technical
documents.

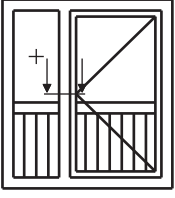

**S-624 ORTA KAYIT & S-624 İÇE AÇILIM KAPI KANAT
BİRLEŞİM DETAYI**
S-624 MULLION & S-624 IN SIDE DOOR SASH APPLICATION DETAIL

Ölçek 1/1 Scale



www.mywin.com.tr

BESE METAL ve PLASTİK
teknik dökümanlarda değişiklik
yapma hakkını saklı tutar.
reserves the right to make any
modifications on technical
documents.

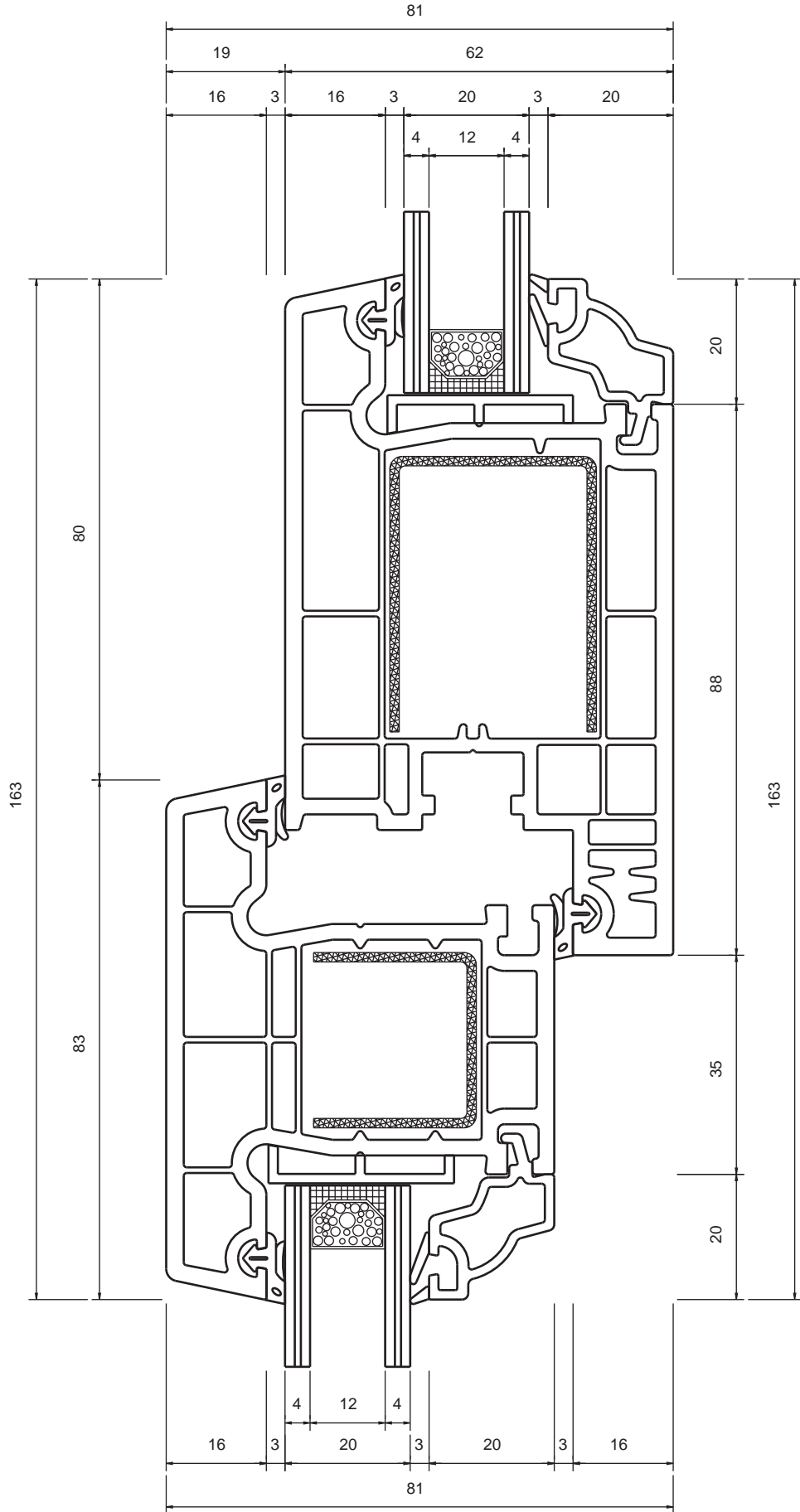

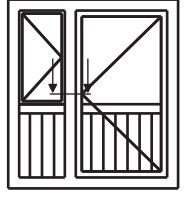
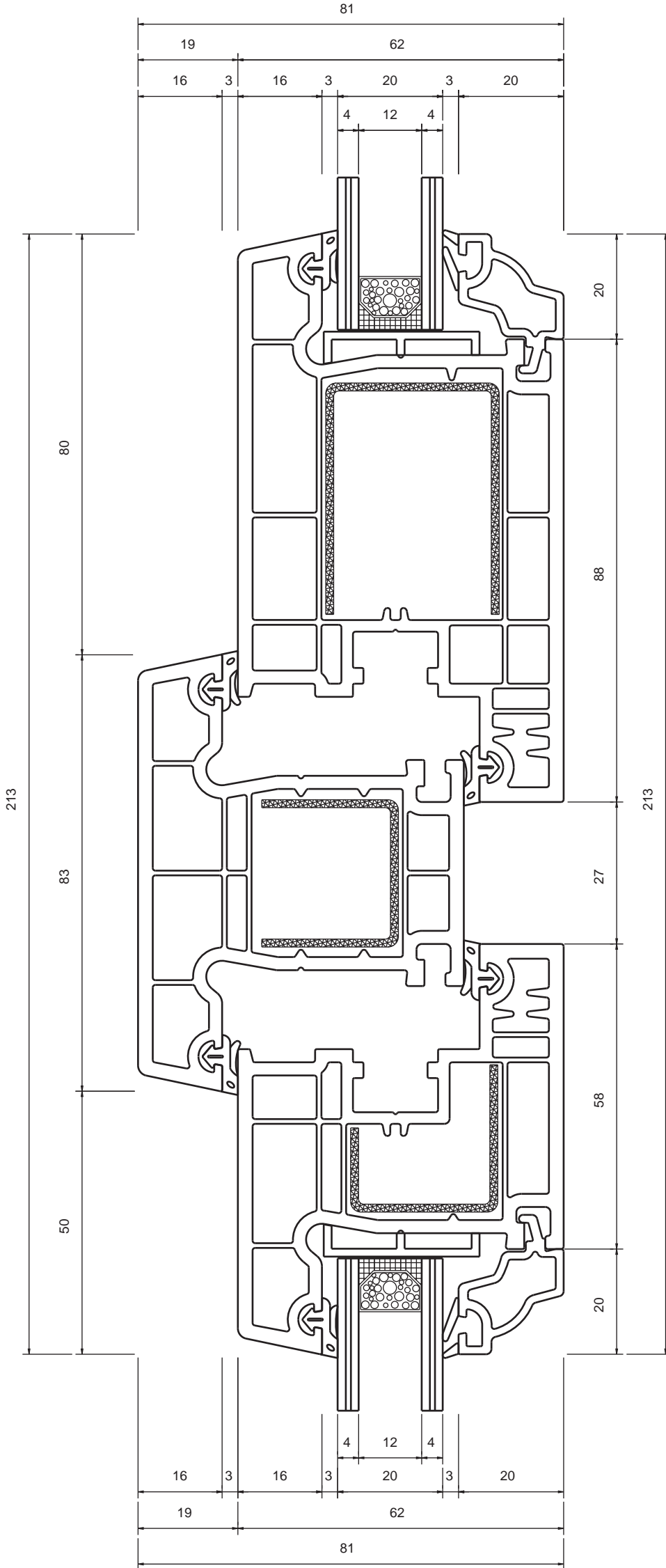

**S-624 KANAT & S-624 ORTA KAYIT &
S-624 İÇE AÇILIM KAPI KANAT BİRLEŞİM DETAYI**
S-624 SASH & S-624 MULLION & S-624 IN SIDE DOOR SASH APPLICATION DETAIL

Ölçek 1/1 Scale



www.mywin.com.tr

BESE METAL ve PLASTİK
teknik dökümanlarda değişiklik
yapma hakkını saklı tutar.
reserves the right to make any
modifications on technical
documents.

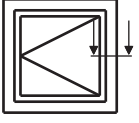

S-624 MONTAJ DETAYI

S-624 MOUNTING DETAIL

Ölçek 1/1 Scale



www.mywin.com.tr

BESE METAL ve PLASTİK
teknik dökümanlarda değişiklik
yapma hakkını saklı tutar.
reserves the right to make any
modifications on technical
documents.

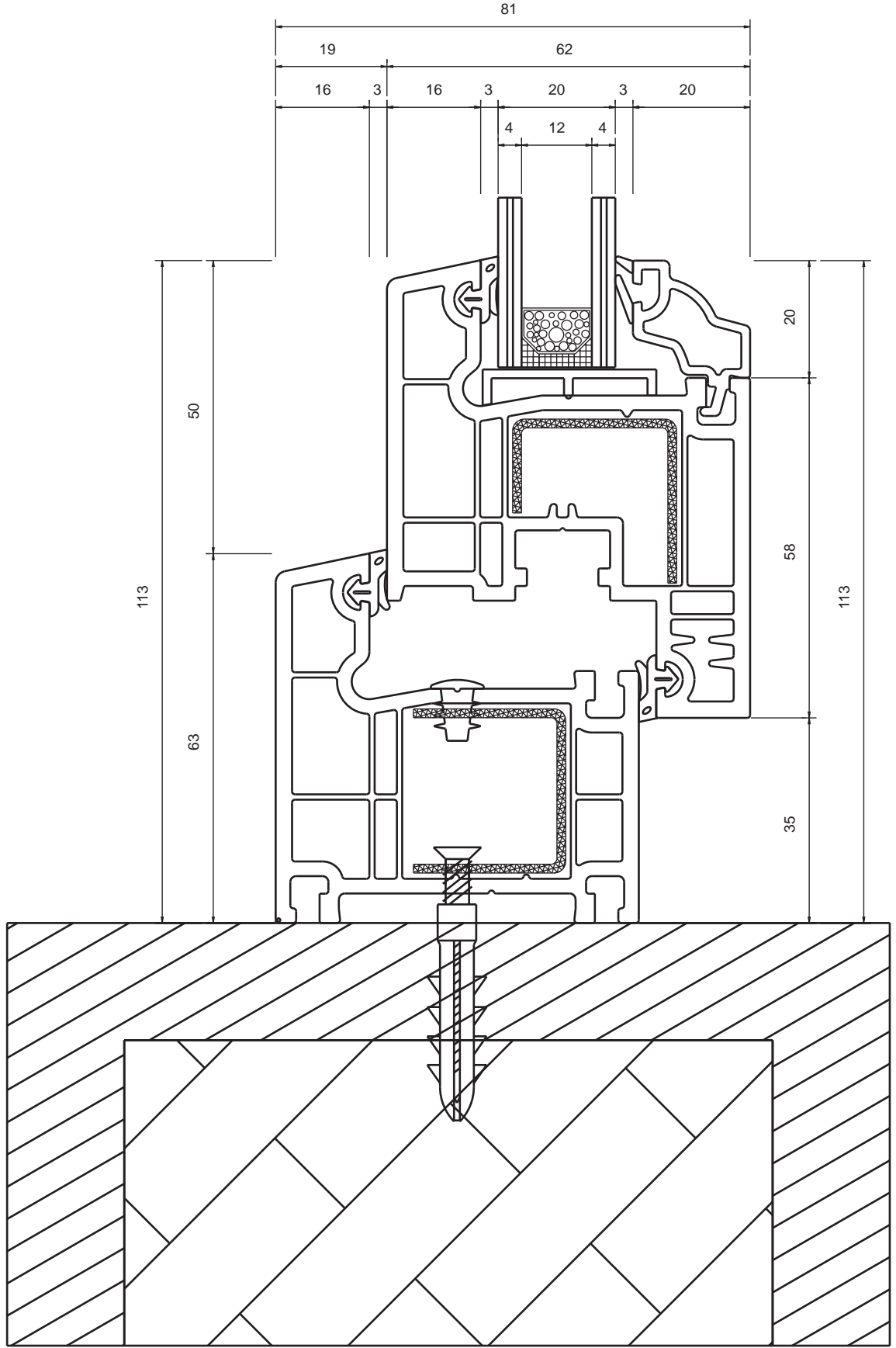

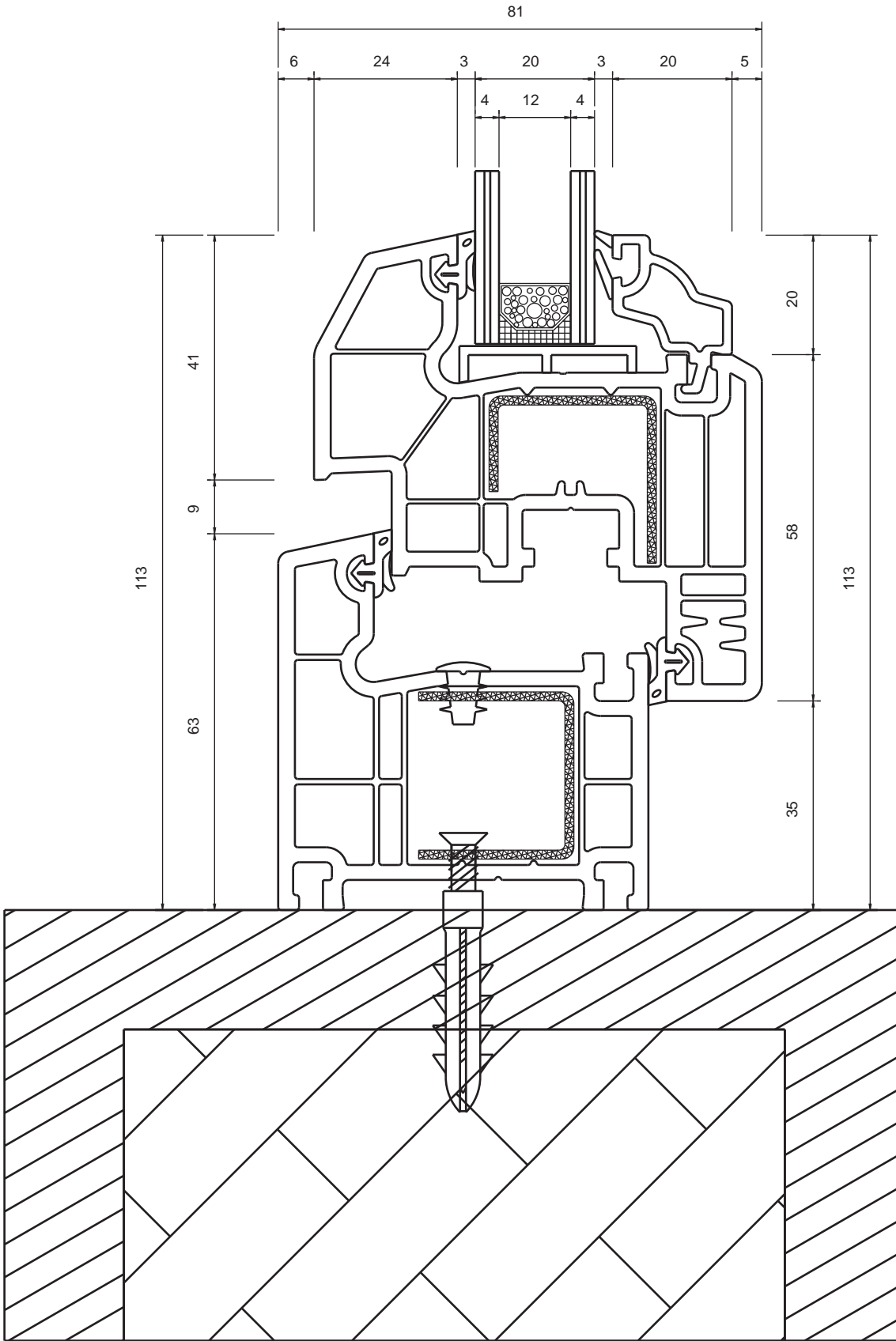
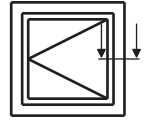

S-624 MONTAJ DETAYI

S-624 MOUNTING DETAIL

Ölçek 1/1 Scale



www.mywin.com.tr

BESE METAL ve PLASTİK
teknik dökümanlarda değişiklik
yapma hakkını saklı tutar.
reserves the right to make any
modifications on technical
documents.

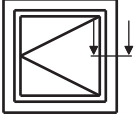

S-624 MONTAJ DETAYI

S-624 MOUNTING DETAIL

Ölçek 1/1 Scale



www.mywin.com.tr

BESE METAL ve PLASTİK
teknik dökümanlarda değişiklik
yapma hakkını saklı tutar.
reserves the right to make any
modifications on technical
documents.

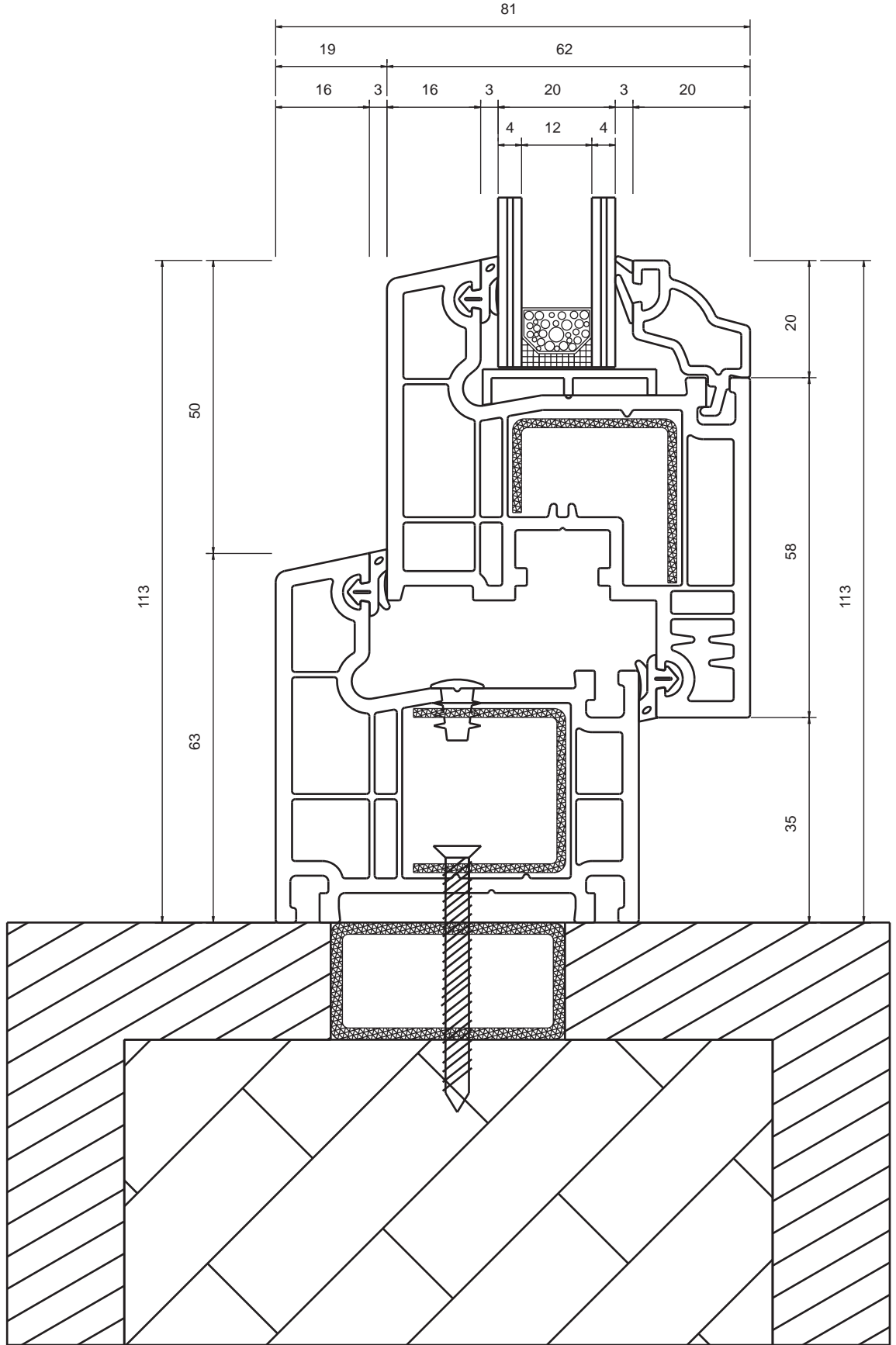

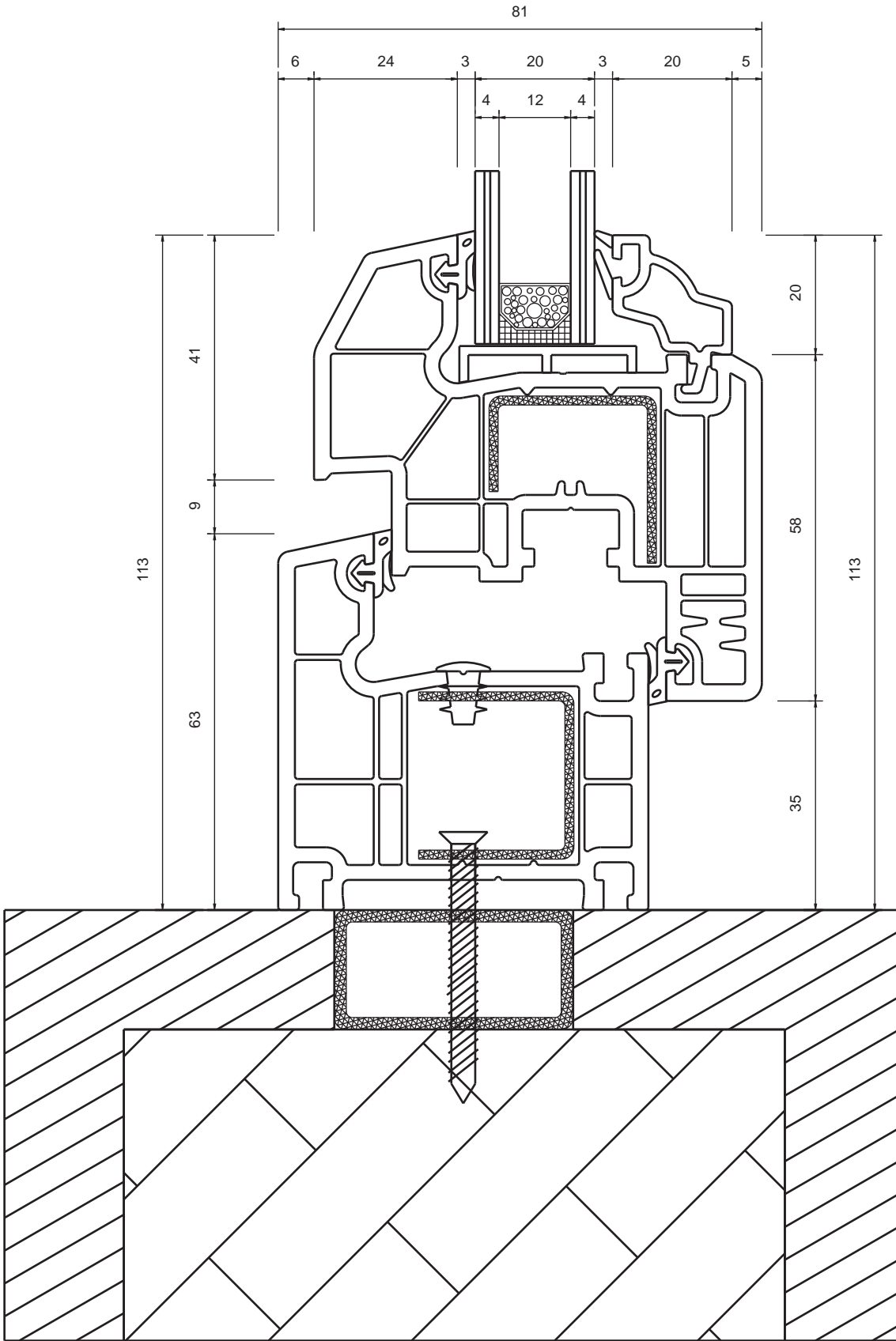
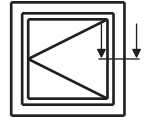

S-624 MONTAJ DETAYI

S-624 MOUNTING DETAIL

Ölçek 1/1 Scale



www.mywin.com.tr

BESE METAL ve PLASTİK
teknik dökümanlarda değişiklik
yapma hakkını saklı tutar.
reserves the right to make any
modifications on technical
documents.

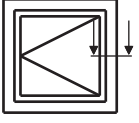

S-624 MONTAJ DETAYI

S-624 MOUNTING DETAIL

Ölçek 1/1 Scale



www.mywin.com.tr

BESE METAL ve PLASTİK
teknik dökümanlarda değişiklik
yapma hakkını saklı tutar.
reserves the right to make any
modifications on technical
documents.

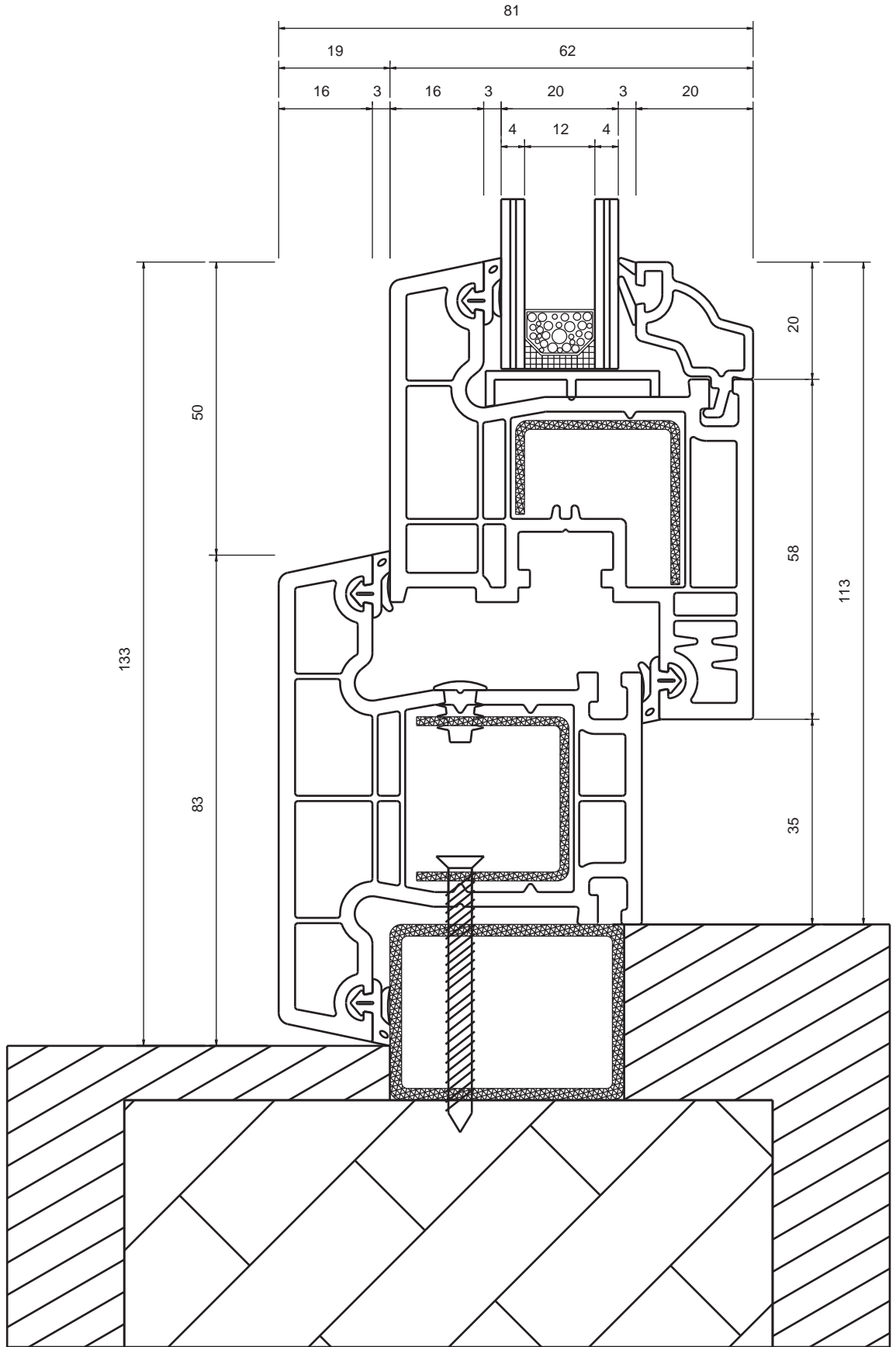

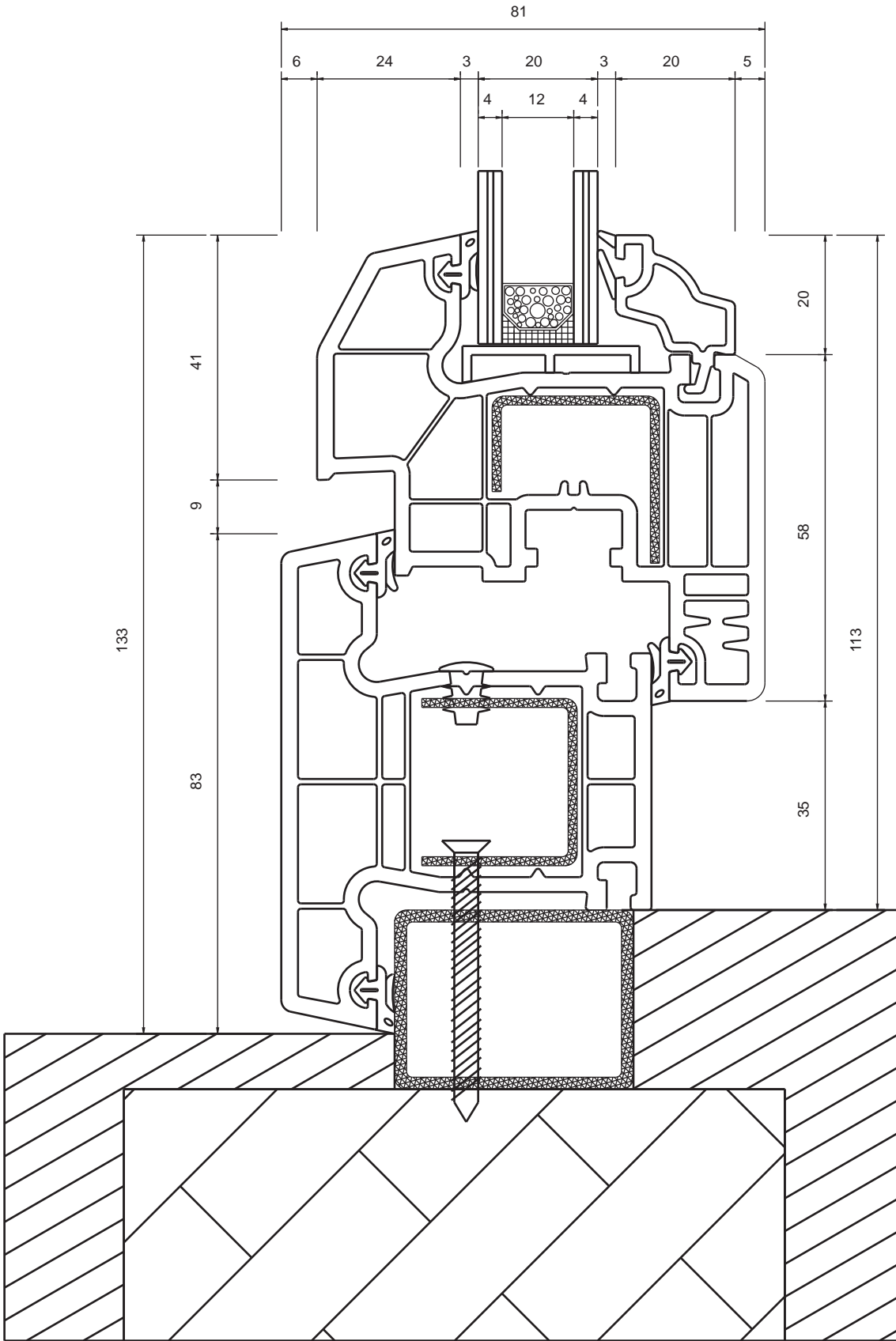
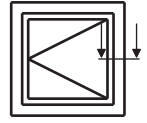

S-624 MONTAJ DETAYI

S-624 MOUNTING DETAIL

Ölçek 1/1 Scale



www.mywin.com.tr

BESE METAL ve PLASTİK
teknik dökümanlarda değişiklik
yapma hakkını saklı tutar.
reserves the right to make any
modifications on technical
documents.

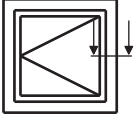

S-624 MONTAJ DETAYI

S-624 MOUNTING DETAIL

Ölçek 1/1 Scale



www.mywin.com.tr

BESE METAL ve PLASTİK
teknik dökümanlarda değişiklik
yapma hakkını saklı tutar.
reserves the right to make any
modifications on technical
documents.

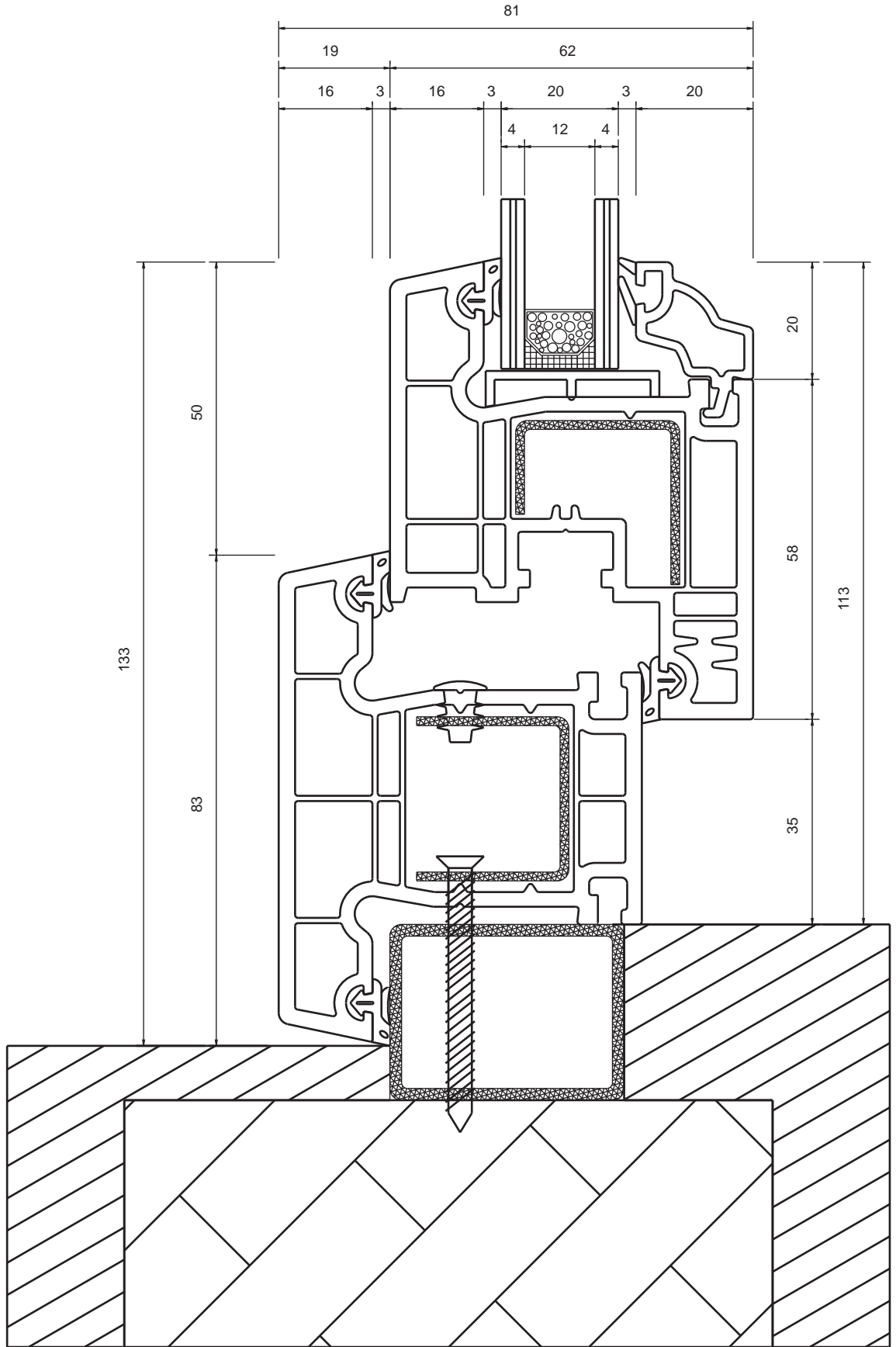

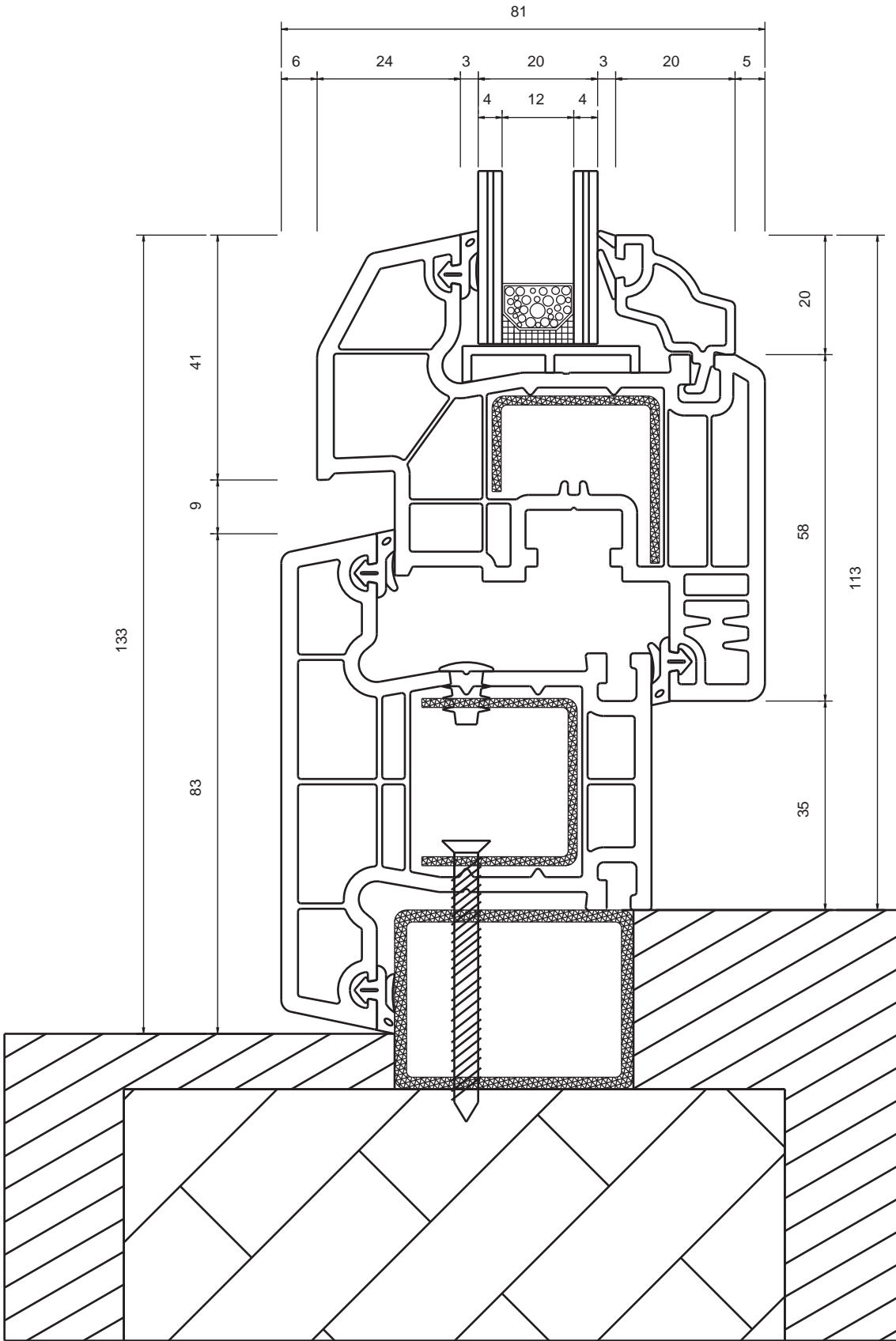
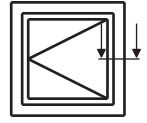

S-624 MONTAJ DETAYI

S-624 MOUNTING DETAIL

Ölçek 1/1 Scale



www.mywin.com.tr

BESE METAL ve PLASTİK
teknik dökümanlarda değişiklik
yapma hakkını saklı tutar.
reserves the right to make any
modifications on technical
documents.

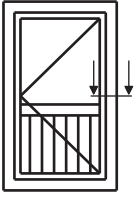

S-624 MONTAJ DETAYI

S-624 MOUNTING DETAIL

Ölçek 1/1 Scale



PVC Window & Door Systems

www.mywin.com.tr

BESE METAL ve PLASTİK
teknik dokümanlarda değişiklik
yapma hakkını saklı tutar.
reserves the right to make any
modifications on technical
documents.

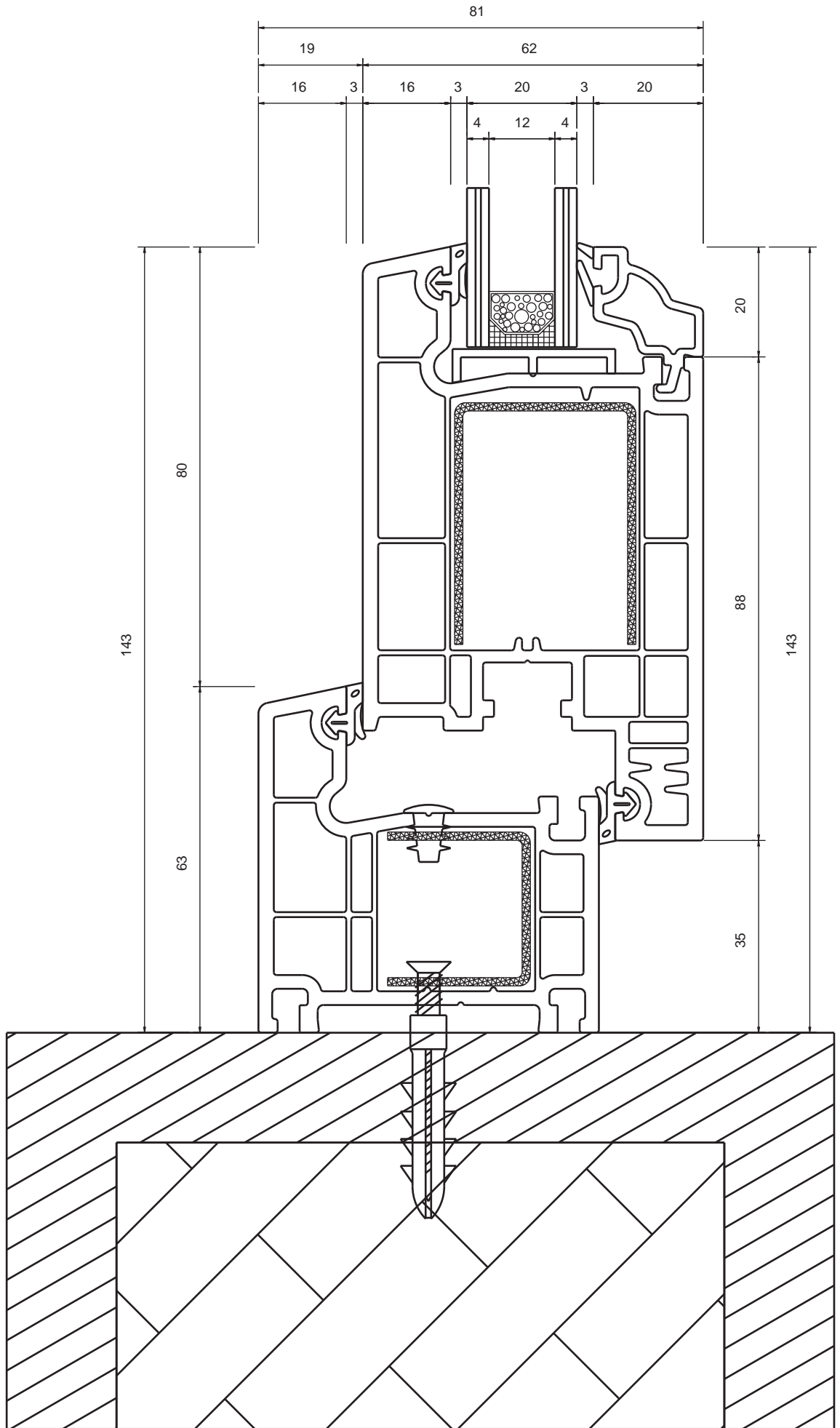

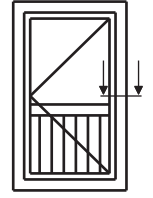
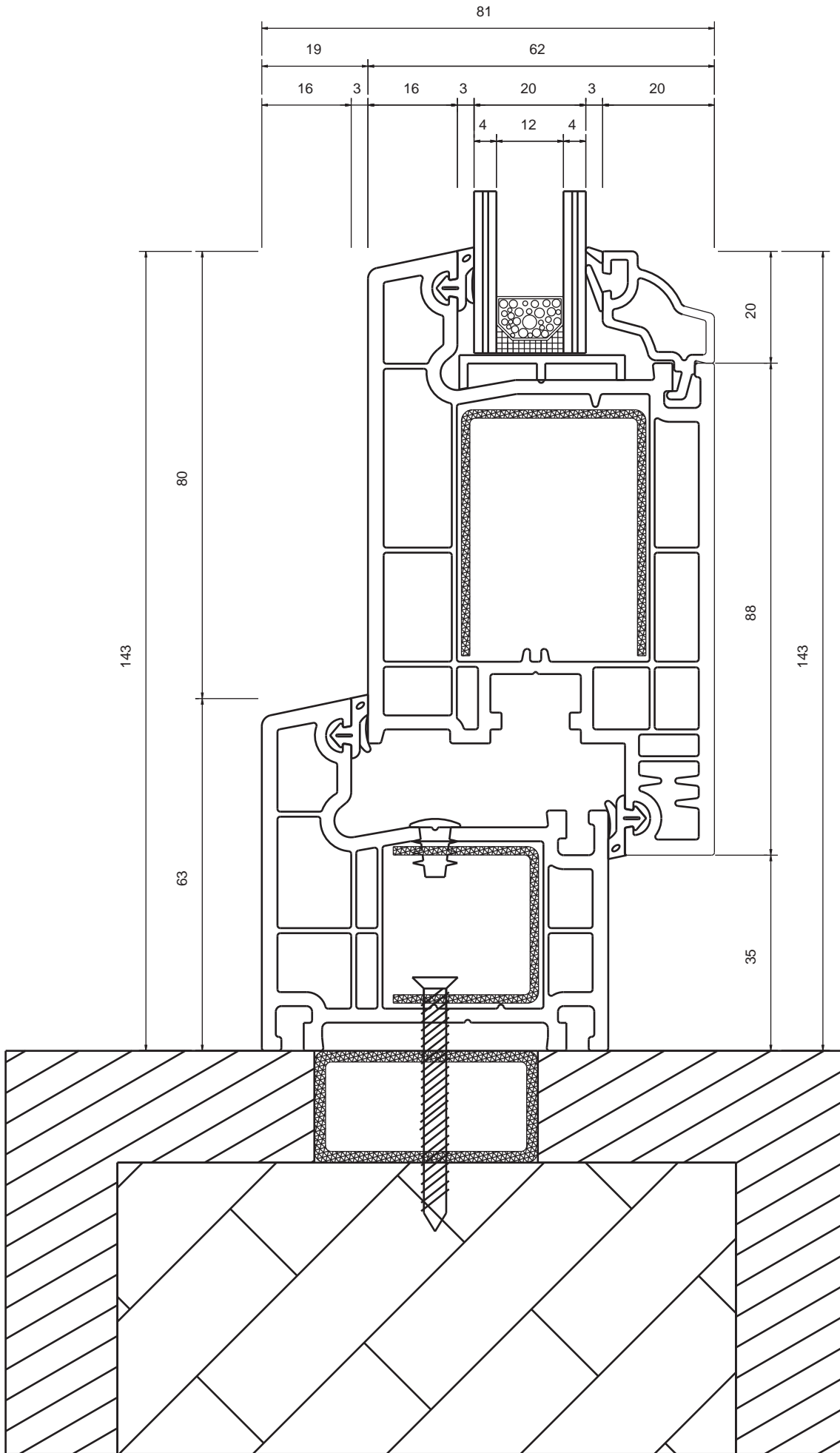

S-624 MONTAJ DETAYI

S-624 MOUNTING DETAIL

Ölçek 1/1 Scale



www.mywin.com.tr

BESE METAL ve PLASTİK
teknik dökümanlarda değişiklik
yapma hakkını saklı tutar.
reserves the right to make any
modifications on technical
documents.

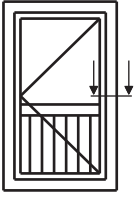

S-624 MONTAJ DETAYI

S-624 MOUNTING DETAIL

Ölçek 1/1 Scale



www.mywin.com.tr

BESE METAL ve PLASTİK
teknik dökümanlarda değişiklik
yapma hakkını saklı tutar.
reserves the right to make any
modifications on technical
documents.

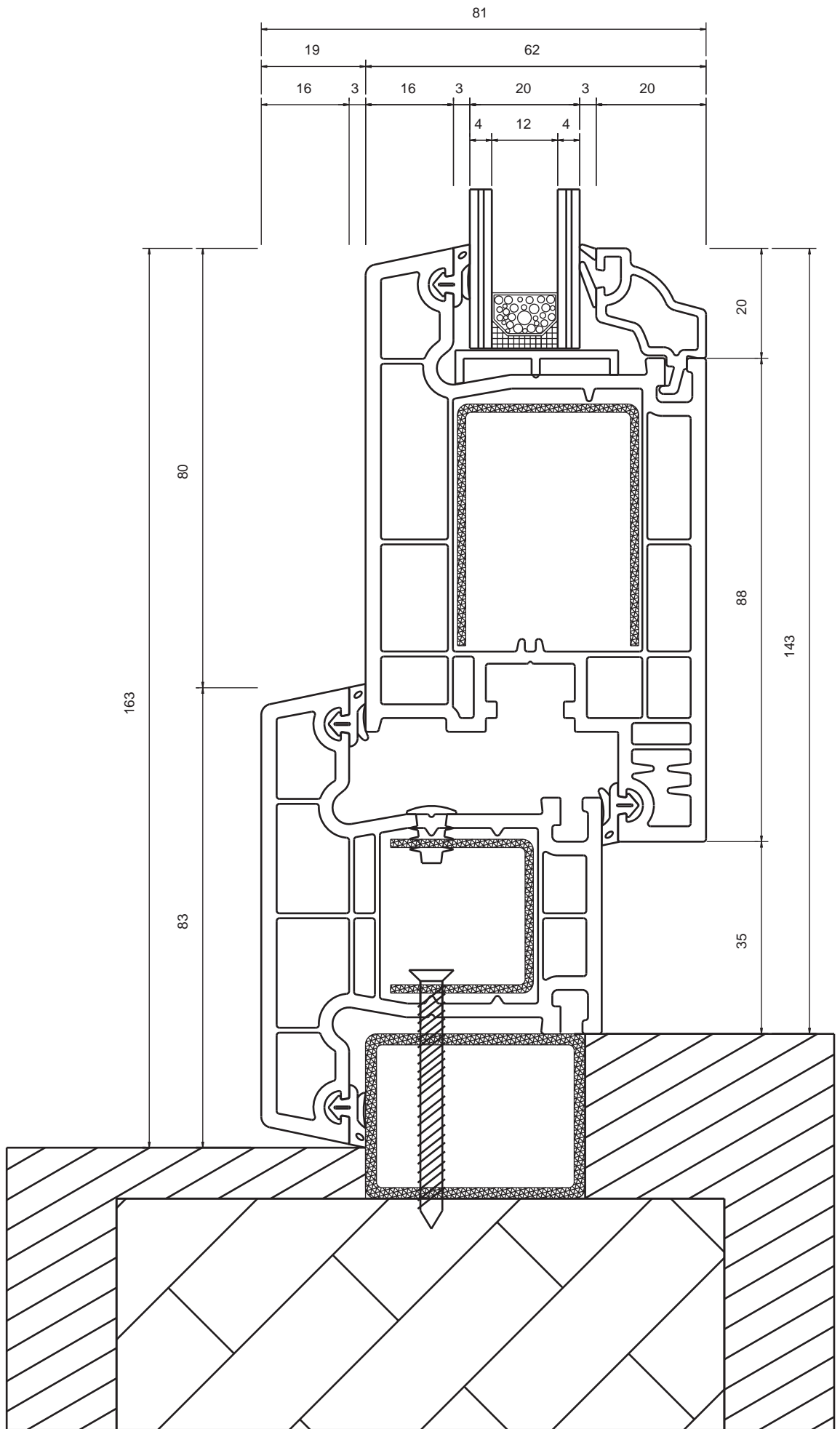

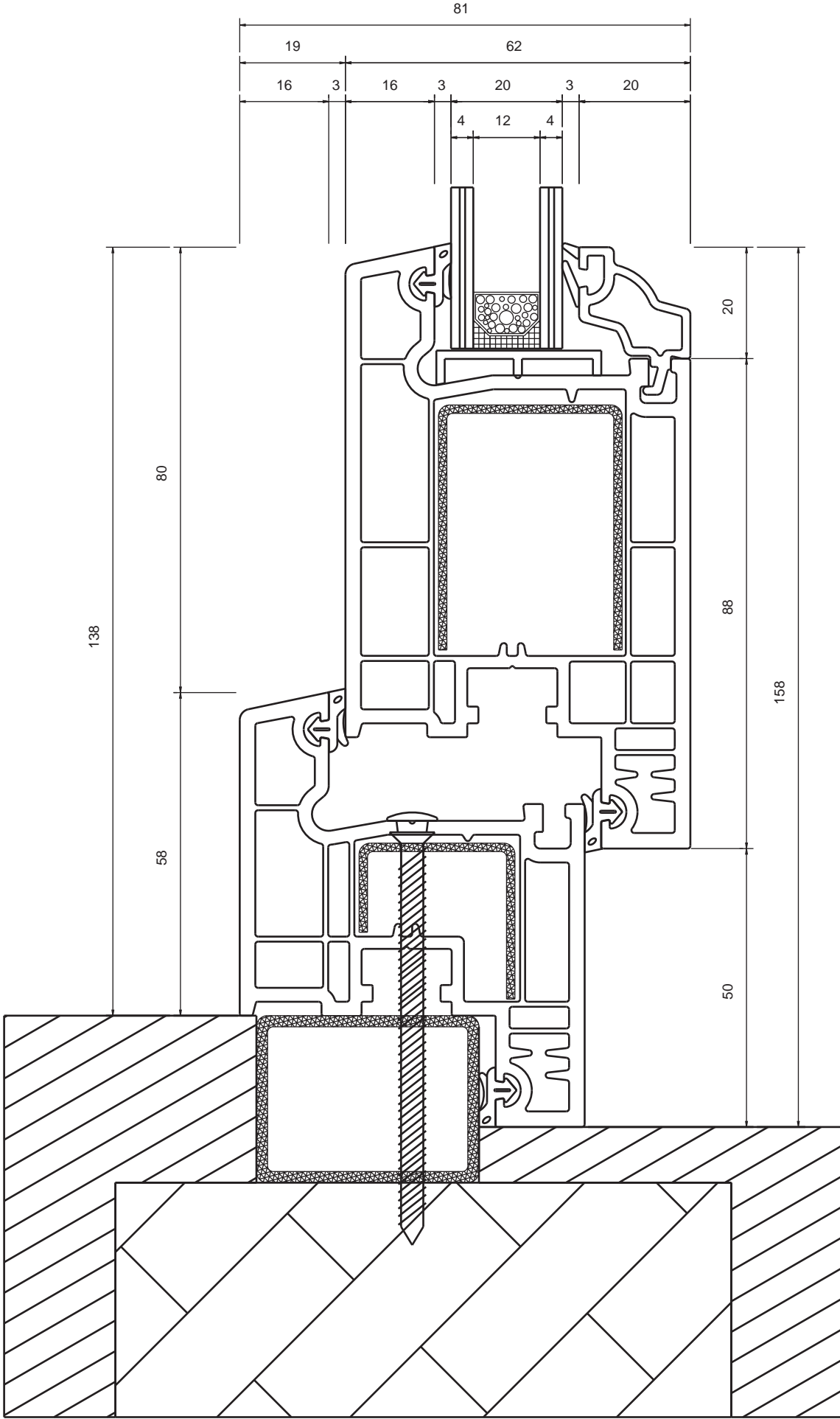
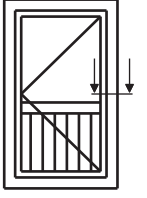

S-624 MONTAJ DETAYI

S-624 MOUNTING DETAIL

Ölçek 1/1 Scale



www.mywin.com.tr

BESE METAL ve PLASTİK
teknik dökümanlarda değişiklik
yapma hakkını saklı tutar.
reserves the right to make any
modifications on technical
documents.

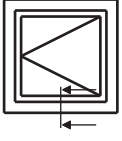

S-624 SU TAHLİYE DETAYI

S-624 WATER DRAINAGE DETAIL

Ölçek 1/1 Scale



PVC Window & Door Systems

www.mywin.com.tr

BESE METAL ve PLASTİK
teknik dokümanlarda değişiklik
yapma hakkını saklı tutar.
reserves the right to make any
modifications on technical
documents.

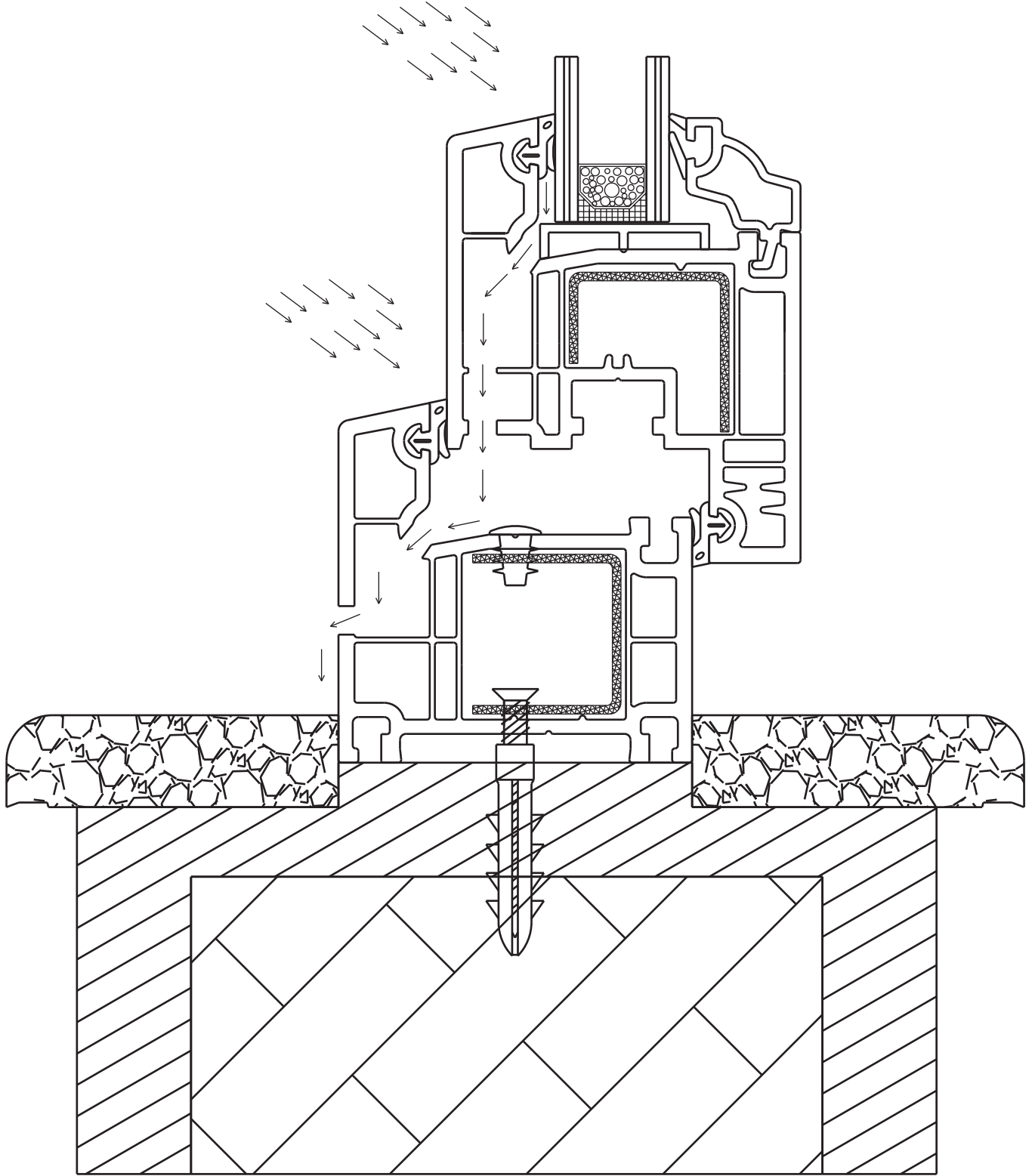

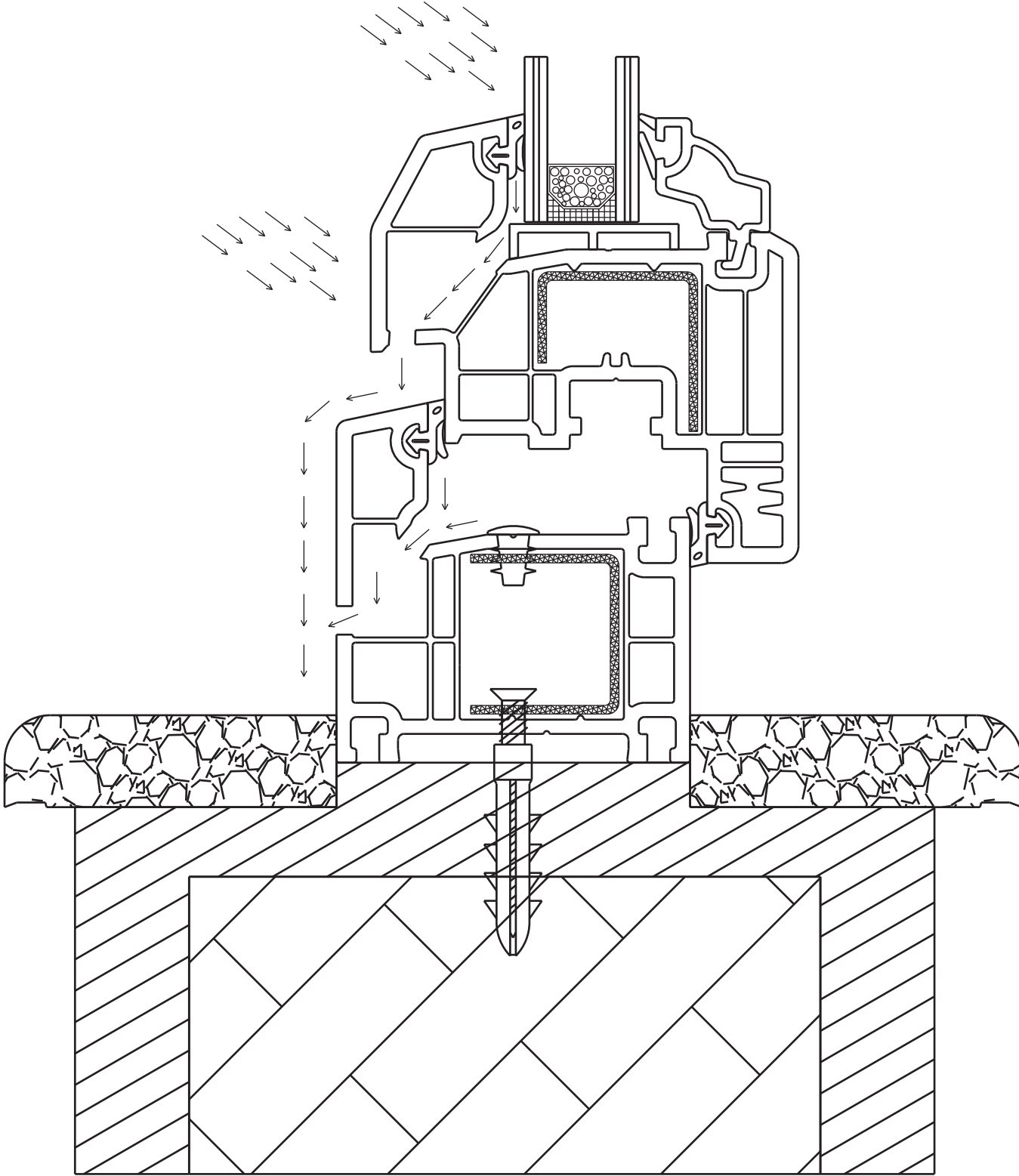
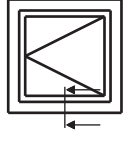

S-624 SU TAHLİYE DETAYI
S-624 WATER DRAINAGE DETAIL

Ölçek 1/1 Scale



www.mywin.com.tr

BESE METAL ve PLASTİK
teknik dökümanlarda değişiklik
yapma hakkını saklı tutar.
reserves the right to make any
modifications on technical
documents.

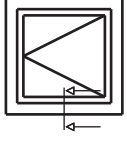

S-624 SU TAHLİYE DETAYI

S-624 WATER DRAINAGE DETAIL

Ölçek 1/1 Scale



www.mywin.com.tr

BESE METAL ve PLASTİK
teknik dokümanlarda değişiklik
yapma hakkını saklı tutar.
reserves the right to make any
modifications on technical
documents.

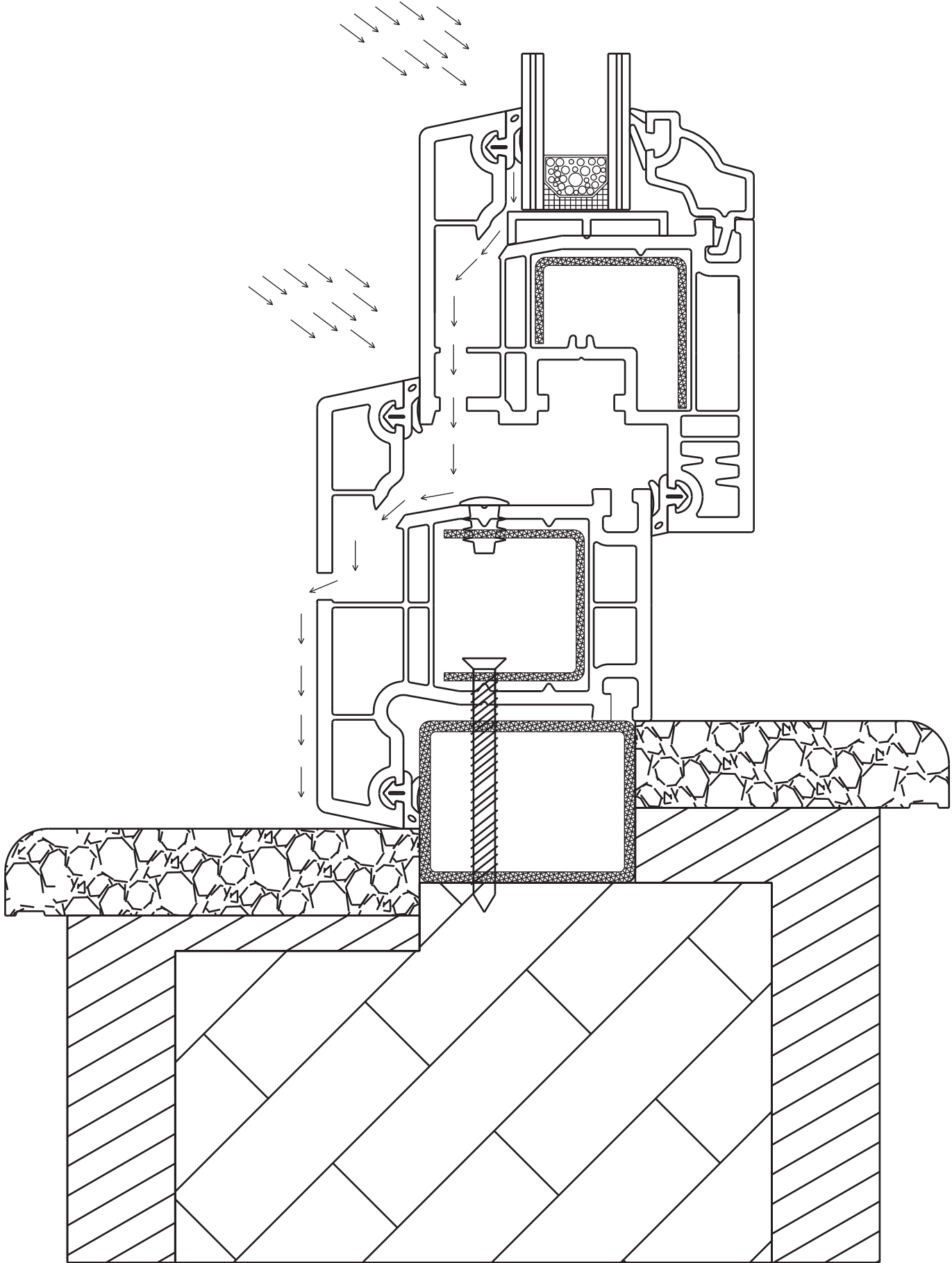

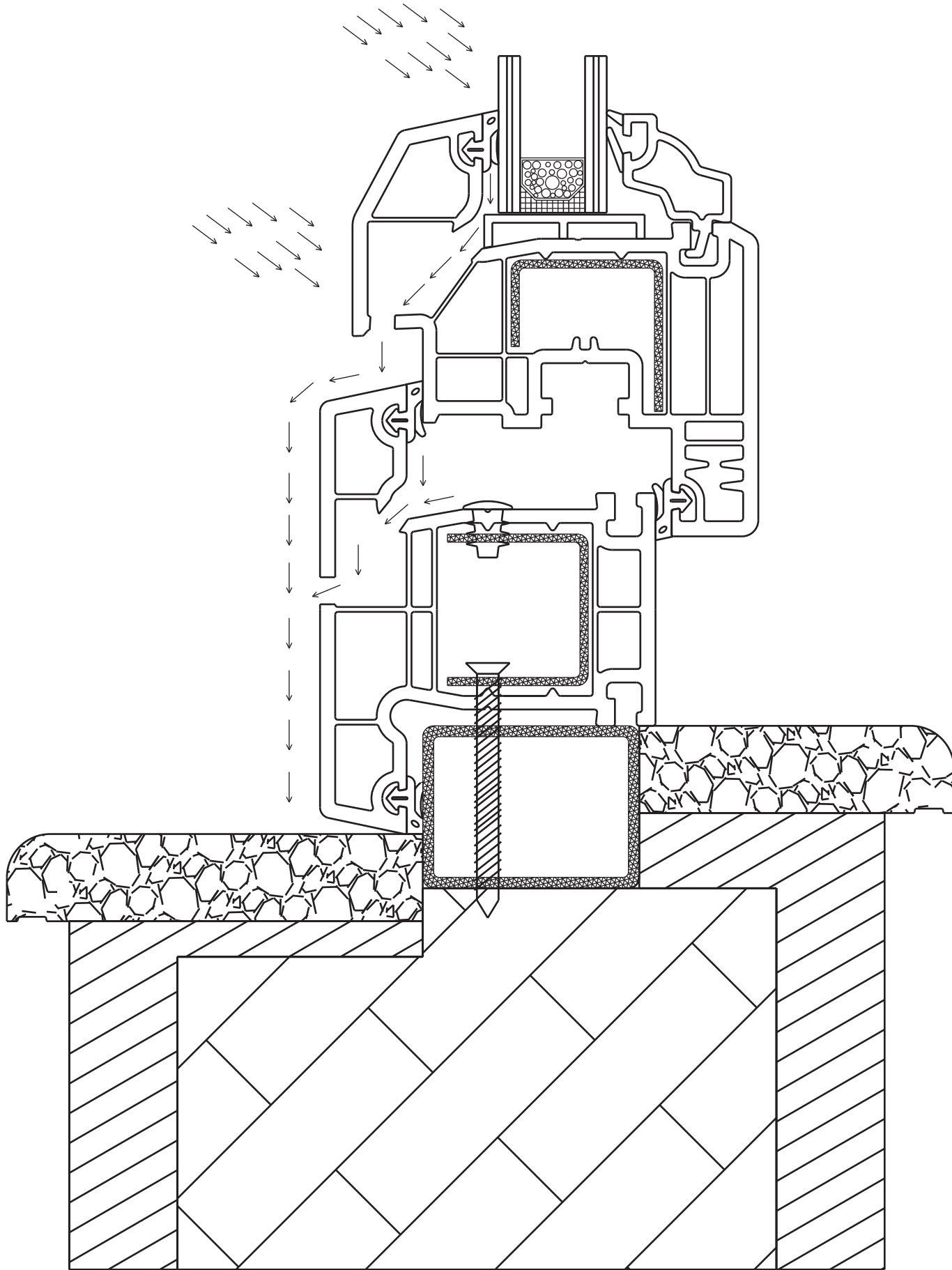
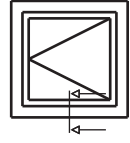

S-624 SU TAHLİYE DETAYI

S-624 WATER DRAINAGE DETAIL

Ölçek 1/1 Scale



www.mywin.com.tr

BESE METAL ve PLASTİK
teknik dökümanlarda değişiklik
yapma hakkını saklı tutar.
reserves the right to make any
modifications on technical
documents.

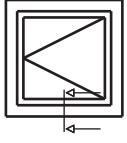

S-624 SU TAHLİYE DETAYI

S-624 WATER DRAINAGE DETAIL

Ölçek 1/1 Scale



www.mywin.com.tr

BESE METAL ve PLASTİK
teknik dökümanlarda değişiklik
yapma hakkını saklı tutar.
reserves the right to make any
modifications on technical
documents.

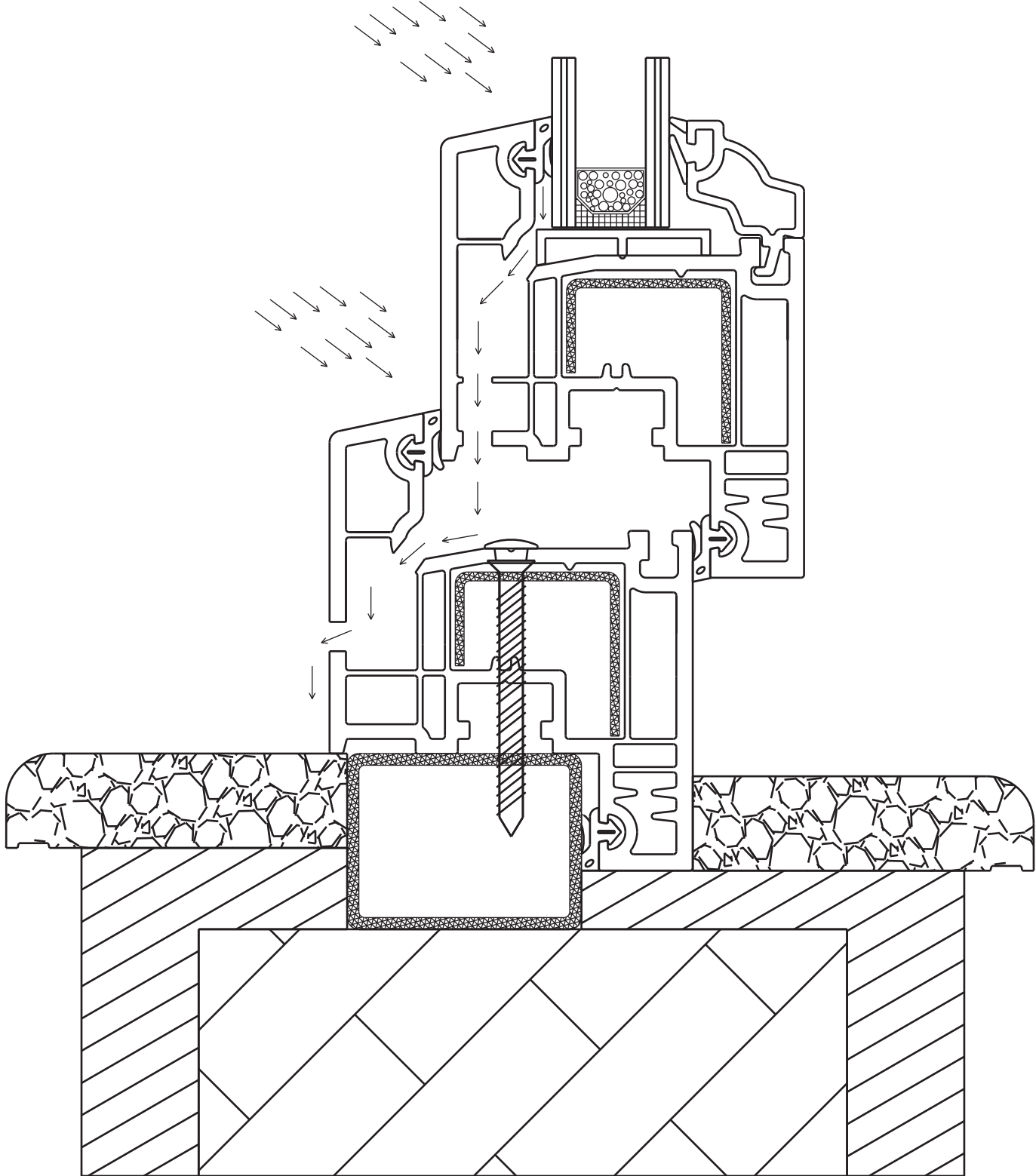

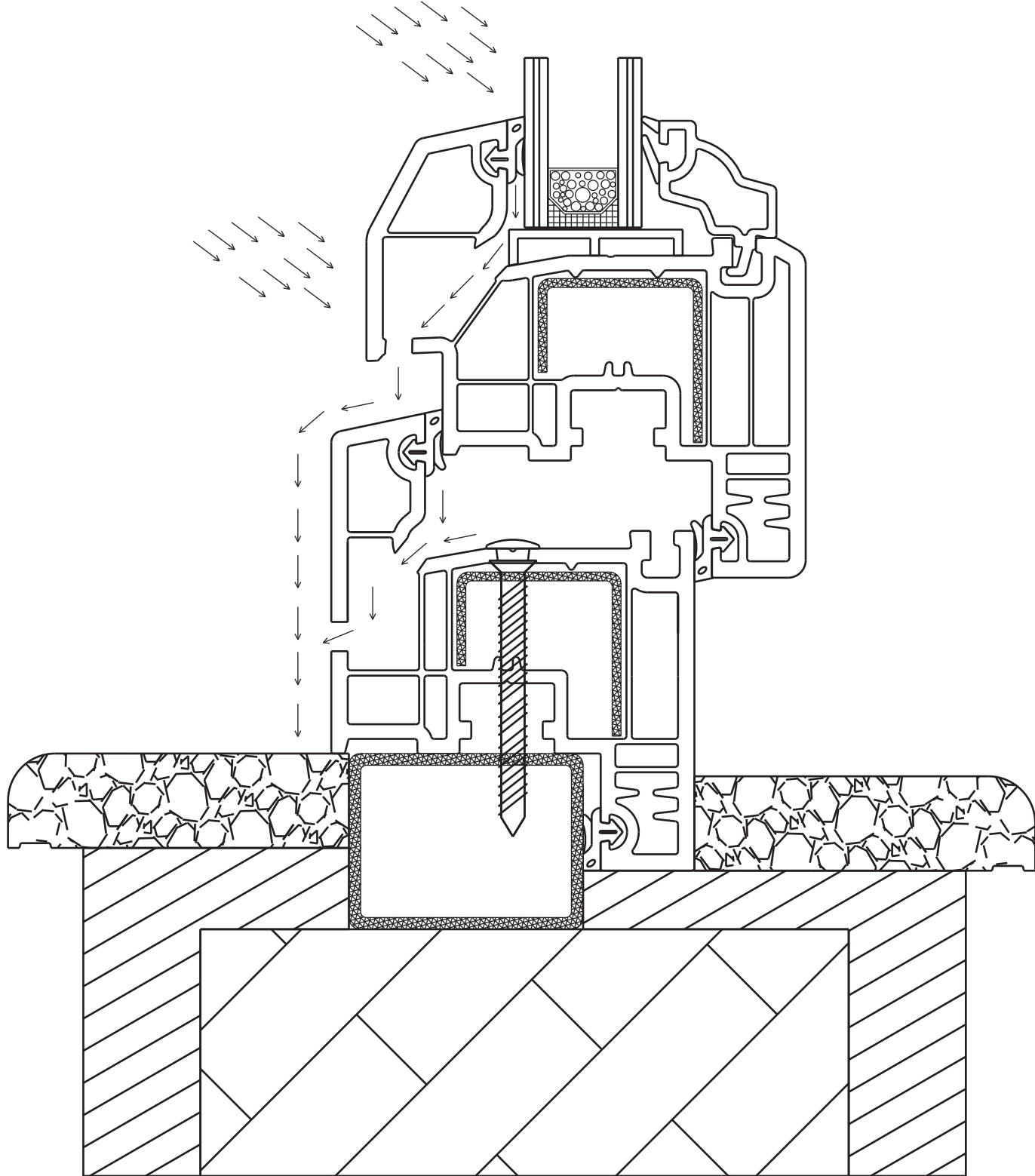
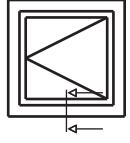

S-624 SU TAHLİYE DETAYI
S-624 WATER DRAINAGE DETAIL

Ölçek 1/1 Scale



www.mywin.com.tr

BESE METAL ve PLASTİK
teknik dökümanlarda değişiklik
yapma hakkını saklı tutar.
reserves the right to make any
modifications on technical
documents.

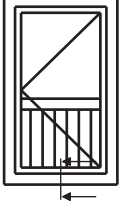

S-624 SU TAHLİYE DETAYI

S-624 WATER DRAINAGE DETAIL

Ölçek 1/1 Scale



PVC Window & Door Systems

www.mywin.com.tr

BESE METAL ve PLASTİK
teknik dokümanlarda değişiklik
yapma hakkını saklı tutar.
reserves the right to make any
modifications on technical
documents.

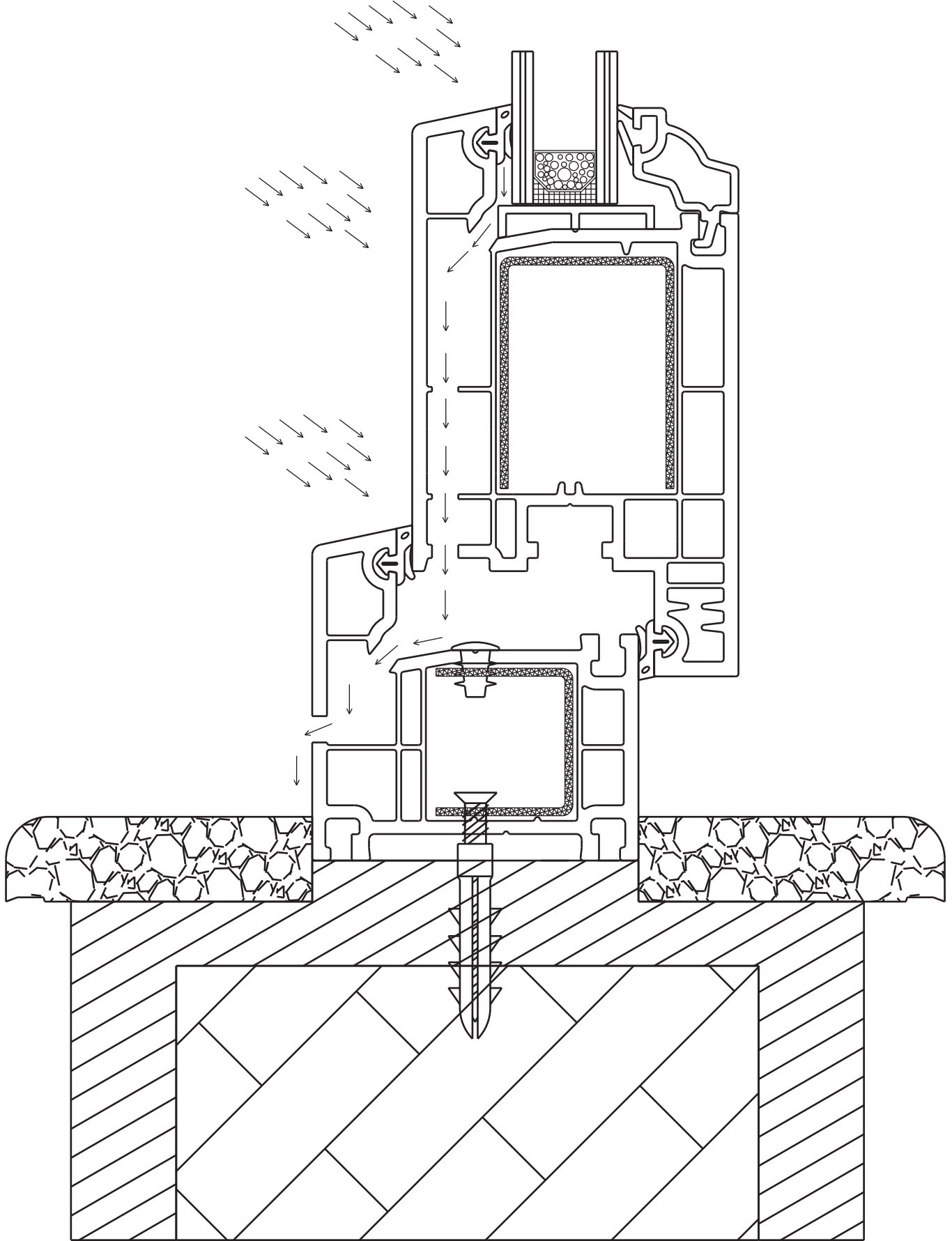

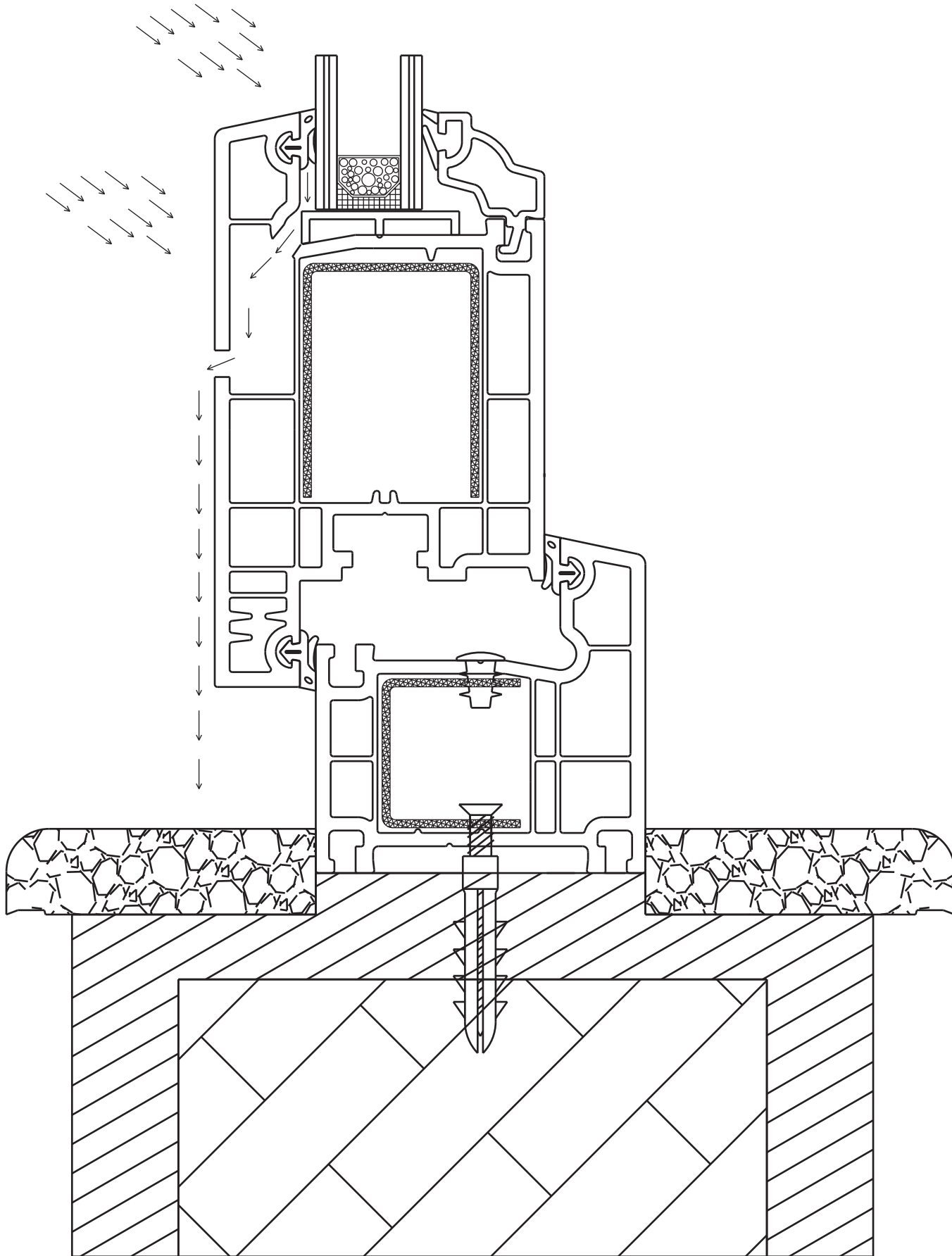
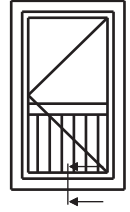

S-624 SU TAHLİYE DETAYI
S-624 WATER DRAINAGE DETAIL

Ölçek 1/1 Scale



www.mywin.com.tr

BESE METAL ve PLASTİK
teknik dökümanlarda değişiklik
yapma hakkını saklı tutar.
reserves the right to make any
modifications on technical
documents.

PVC Window & Door Systems



www.mywin.com.tr



S-705

serisi profilleri

series profiles

S-705 KASA PROFİLİ
Ürün Kodu / Product Code: 705.11.00.0
S-705 FRAME PROFILE

Ölçek 1/1 Scale



www.mywin.com.tr

BESE METAL ve PLASTİK
teknik dokümanlarda değişiklik
yapma hakkını saklı tutar.
reserves the right to make any
modifications on technical
documents.

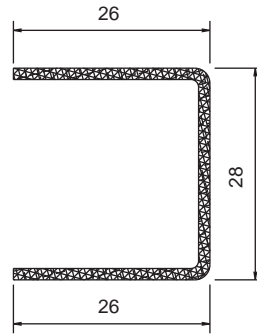
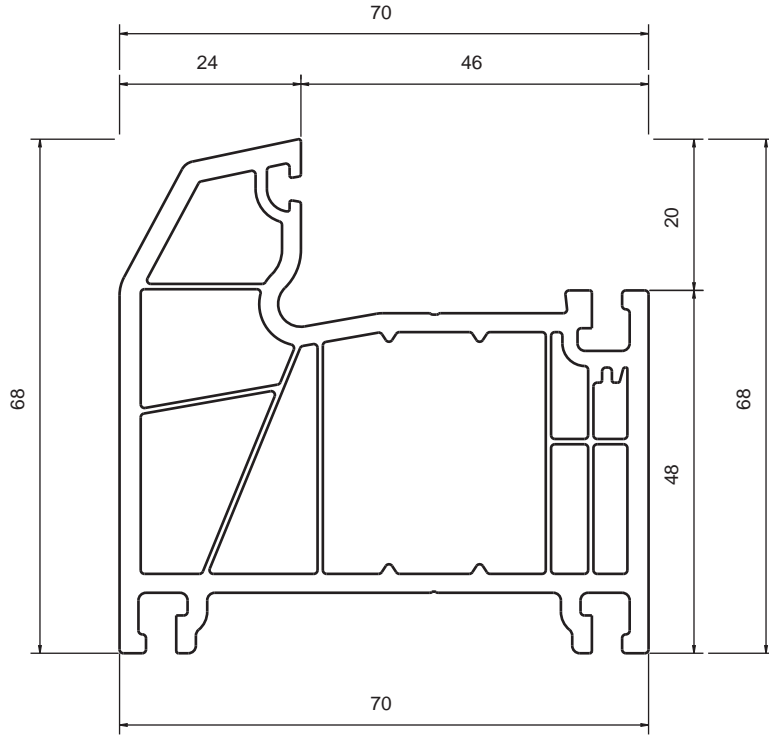

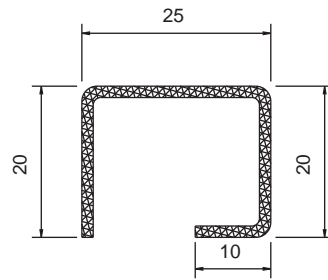
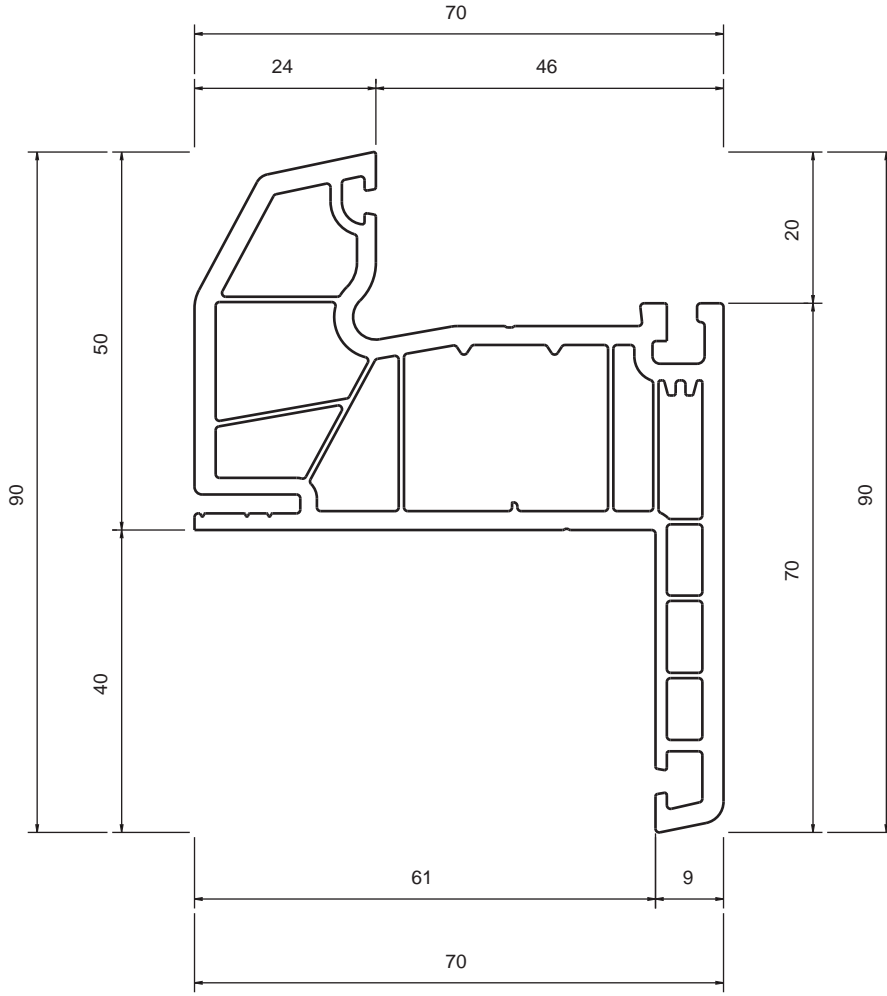

S-705 PERVAZLI KASA PROFİLİ
Ürün Kodu / Product Code: 705.13.00.0
S-705 FRAME WITH BORDER

Ölçek 1/1 Scale



www.mywin.com.tr

BESE METAL ve PLASTİK
teknik dökümanlarda değişiklik
yapma hakkını saklı tutar.
reserves the right to make any
modifications on technical
documents.

S-705 ORTA KAYIT PROFİLİ
Ürün Kodu / Product Code: 705.21.00.0
S-705 MULLION PROFILE

Ölçek 1/1 Scale



www.mywin.com.tr

BESE METAL ve PLASTİK
teknik dokümanlarda değişiklik
yapma hakkını saklı tutar.
reserves the right to make any
modifications on technical
documents.

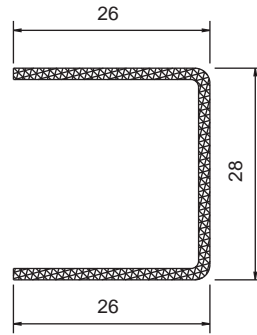
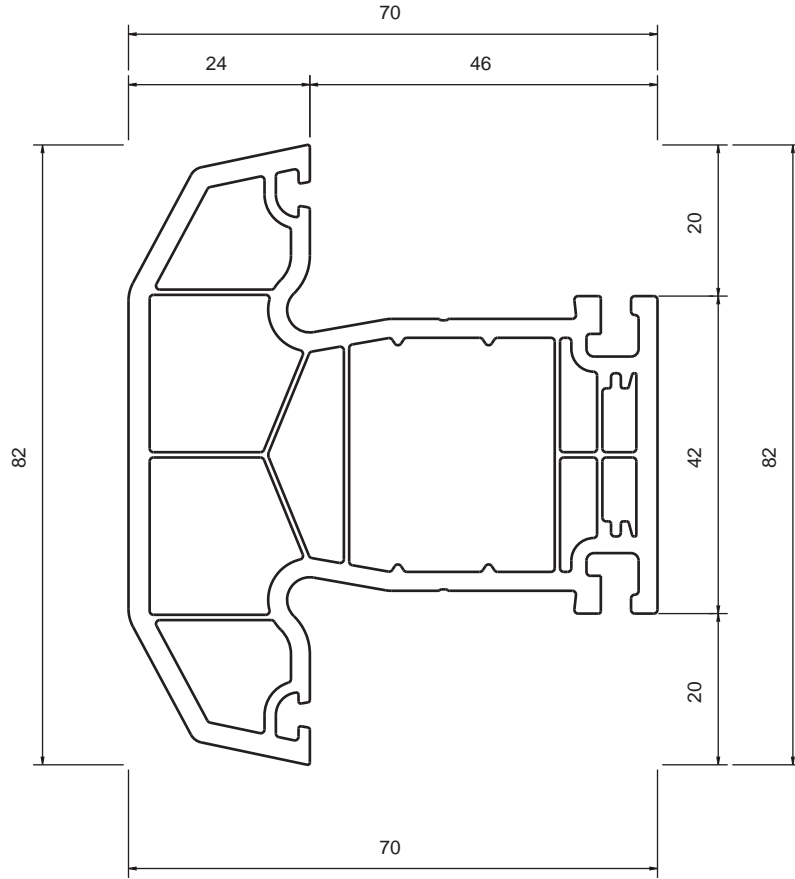

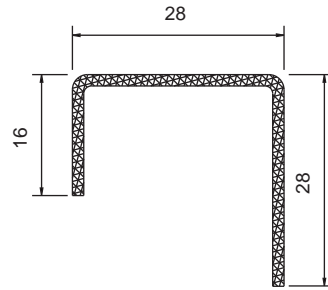
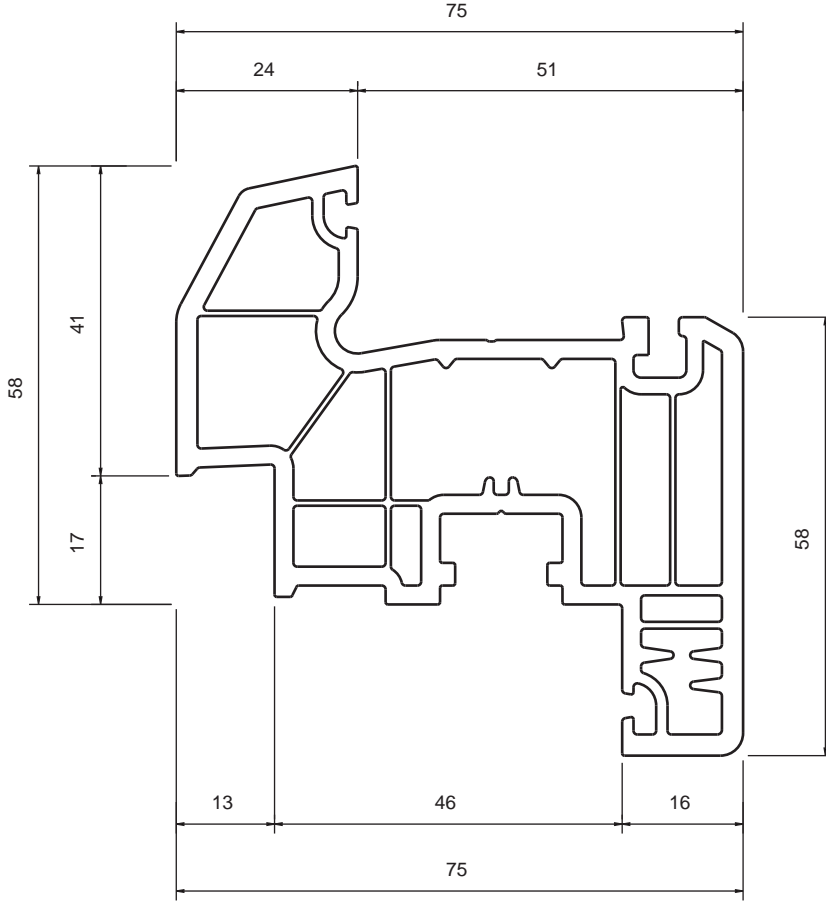

S-705 DAMLALIKLI KANAT PROFİLY
Ürün Kodu / Product Code: 705.31.00.0
S-705 DRAINER SASH PROFILE

Ölçek 1/1 Scale



www.mywin.com.tr

BESE METAL ve PLASTİK
teknik dökümanlarda değişiklik
yapma hakkını saklı tutar.
reserves the right to make any
modifications on technical
documents.

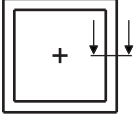

S-705 KASA & 4mm TEK CAM ÇITASI BİRLEŞİM DETAYI

S-705 FRAME & SINGLE GLASS BEAT 4mm APPLICATION DETAIL

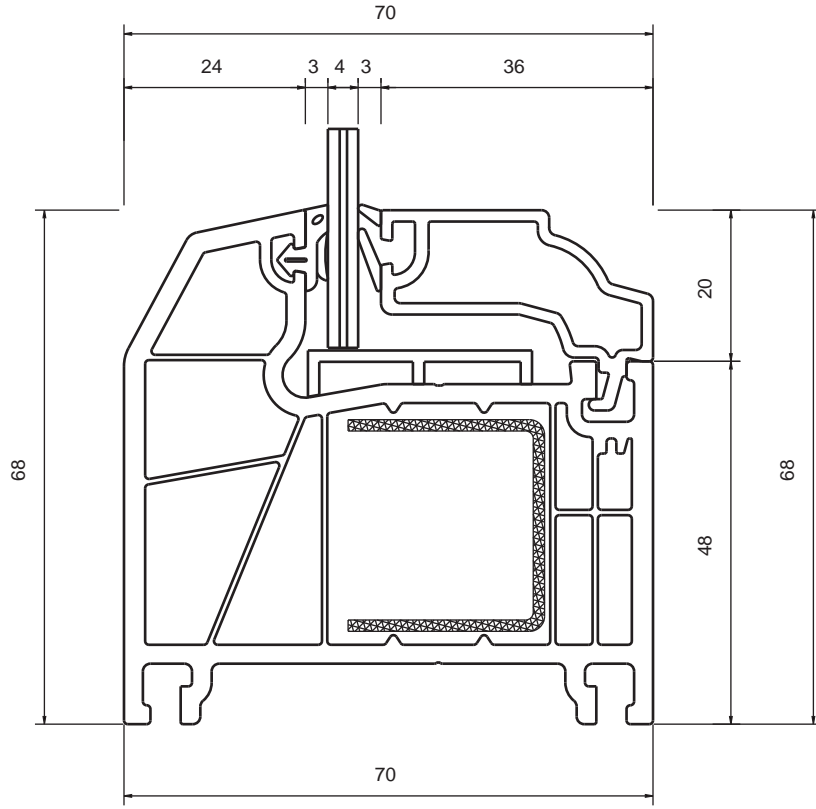

Ölçek 1/1 Scale



www.mywin.com.tr

BESE METAL ve PLASTİK
teknik dökümanlarda değişiklik
yapma hakkını saklı tutar.
reserves the right to make any
modifications on technical
documents.

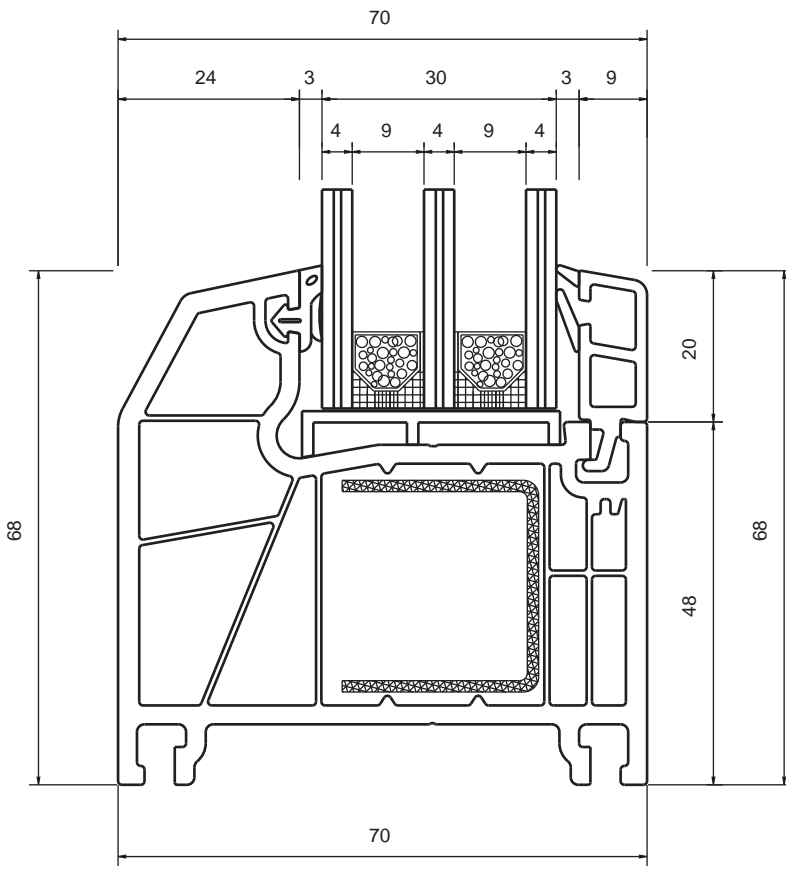
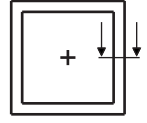

S-705 KASA & 30mm ÜÇLÜ CAM ÇITASI BİRLEŞİM DETAYI
S-705 FRAME & TRIPLE GLASS BEAT 30mm APPLICATION DETAIL

Ölçek 1/1 Scale



www.mywin.com.tr

BESE METAL ve PLASTİK
teknik dökümanlarda değişiklik
yapma hakkını saklı tutar.
reserves the right to make any
modifications on technical
documents.

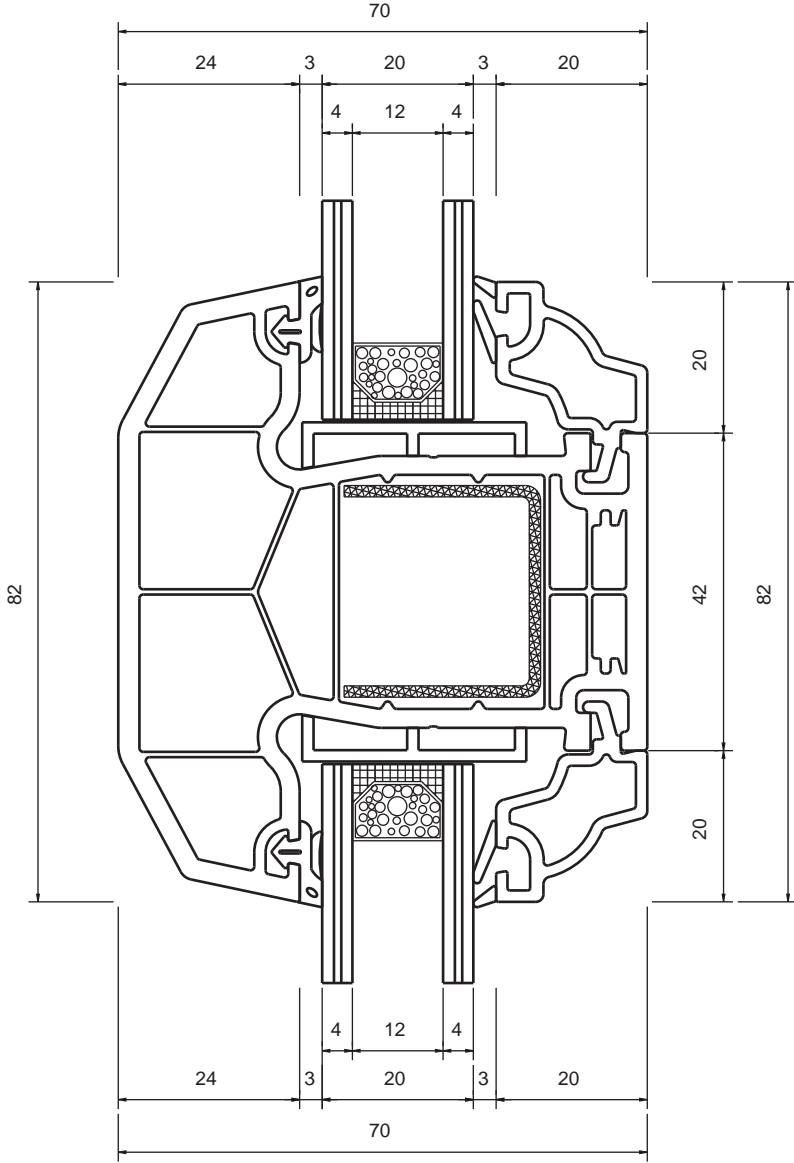
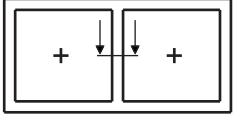

S-705 ORTA KAYIT & 20mm ÇİFT CAM ÇİTASI BİRLEŞİM DETAYI
S-705 MULLION & DOUBLE GLASS BEAT 20mm APPLICATION DETAIL

Ölçek 1/1 Scale



www.mywin.com.tr

BESE METAL ve PLASTİK
teknik dökümanlarda değişiklik
yapma hakkını saklı tutar.
reserves the right to make any
modifications on technical
documents.

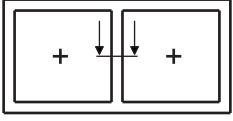

**S-705 ORTA KAYIT & 24mm ÇYFT CAM ÇITASI
BİRLEŞİM DETAYI**
S-705 MULLION & DOUBLE GLASS BEAT 24mm APPLICATION DETAIL

Ölçek 1/1 Scale

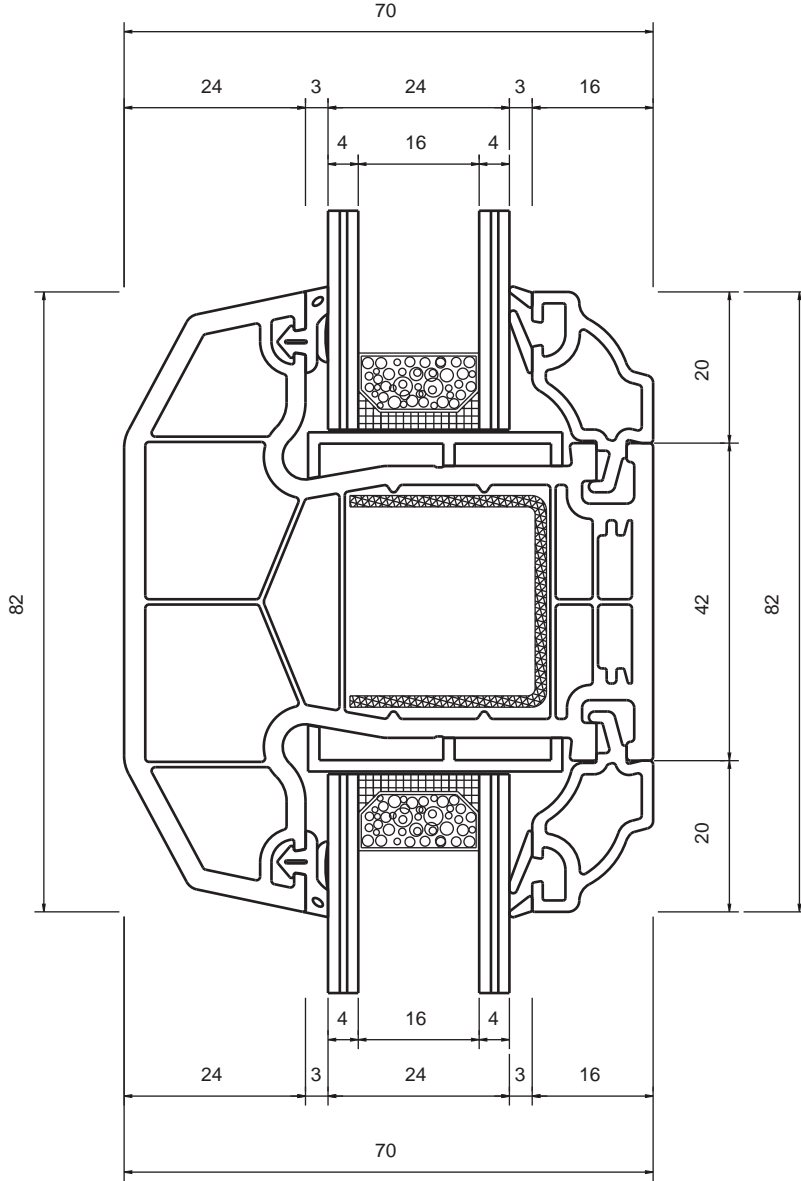

www.mywin.com.tr

BESE METAL ve PLASTİK
teknik dökümanlarda değişiklik
yapma hakkını saklı tutar.
reserves the right to make any
modifications on technical
documents.

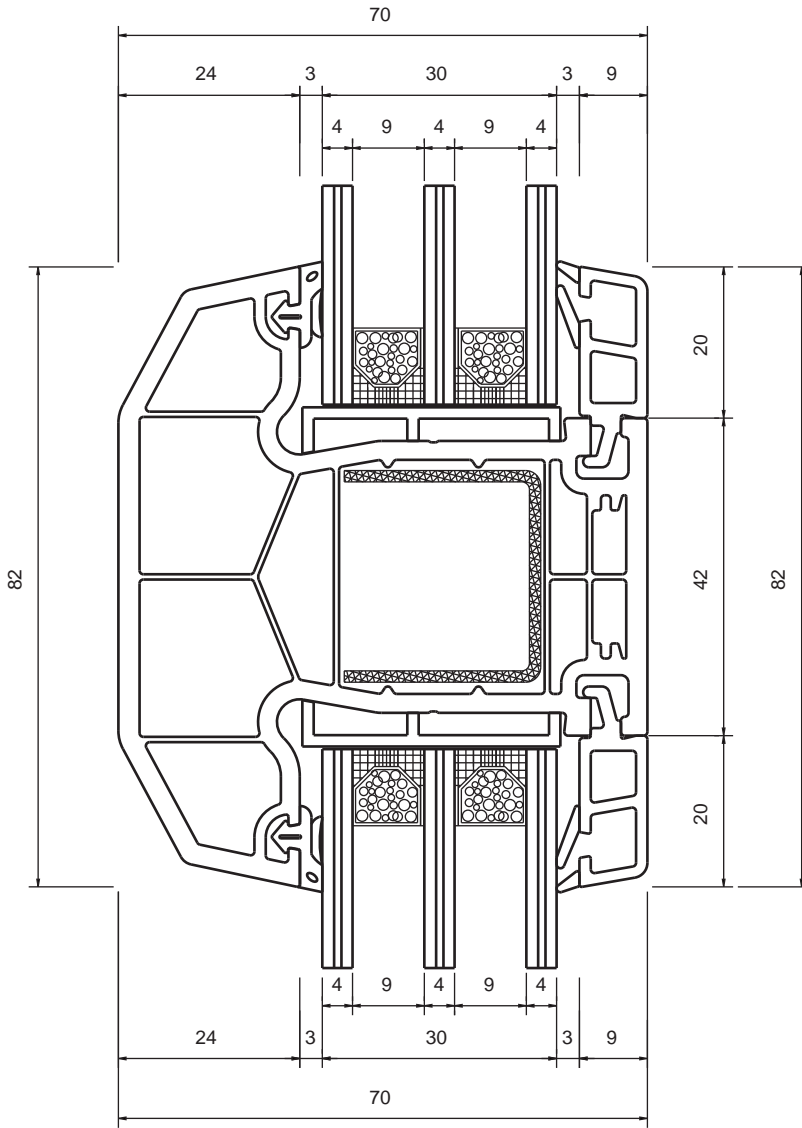
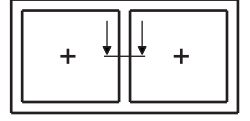

**S-705 ORTA KAYIT & 30mm ÜÇLÜ CAM ÇITASI
BİRLEŞİM DETAYI**
S-705 MULLION & TRIPLE GLASS BEAT 30mm APPLICATION DETAIL

Ölçek 1/1 Scale



www.mywin.com.tr

BESE METAL ve PLASTİK
teknik dökümanlarda değişiklik
yapma hakkını saklı tutar.
reserves the right to make any
modifications on technical
documents.

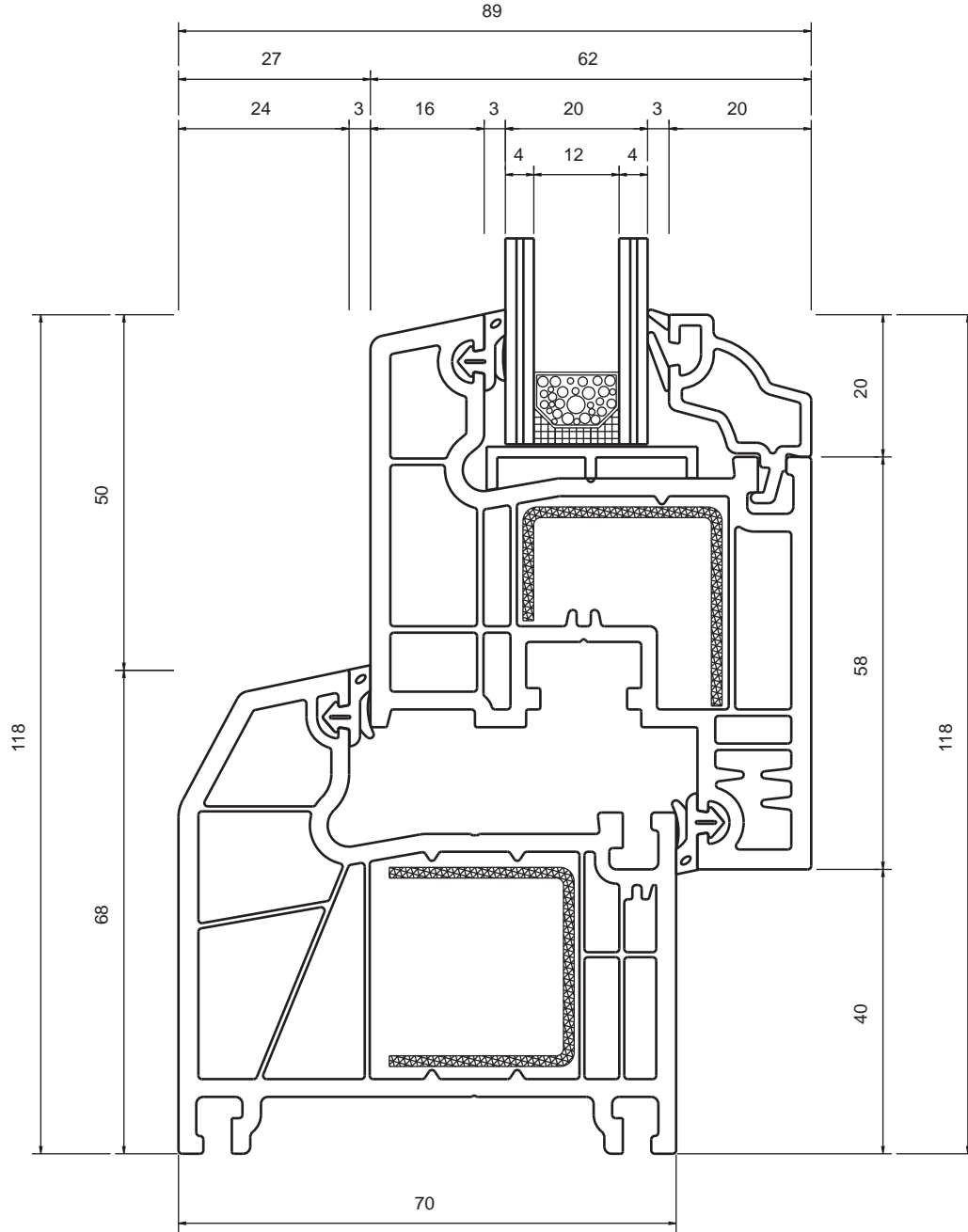
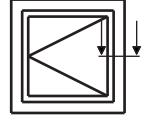

S-705 KASA & S-624 KANAT BİRLEŞİM DETAYI

S-705 FRAME & S-624 SASH APPLICATION DETAIL

Ölçek 1/1 Scale



www.mywin.com.tr

BESE METAL ve PLASTİK
teknik dökümanlarda değişiklik
yapma hakkını saklı tutar.
reserves the right to make any
modifications on technical
documents.

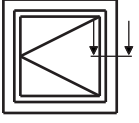

**S-705 PERVAZLI KASA & S-705 DAMLALIKLI KANAT
BİRLEŞİM DETAYI**
S-705 FRAME WITH BORDER & S-705 DRAINER SASH APPLICATION DETAIL

Ölçek 1/1 Scale



www.mywin.com.tr

BESE METAL ve PLASTİK
teknik dökümanlarda değişiklik
yapma hakkını saklı tutar.
reserves the right to make any
modifications on technical
documents.

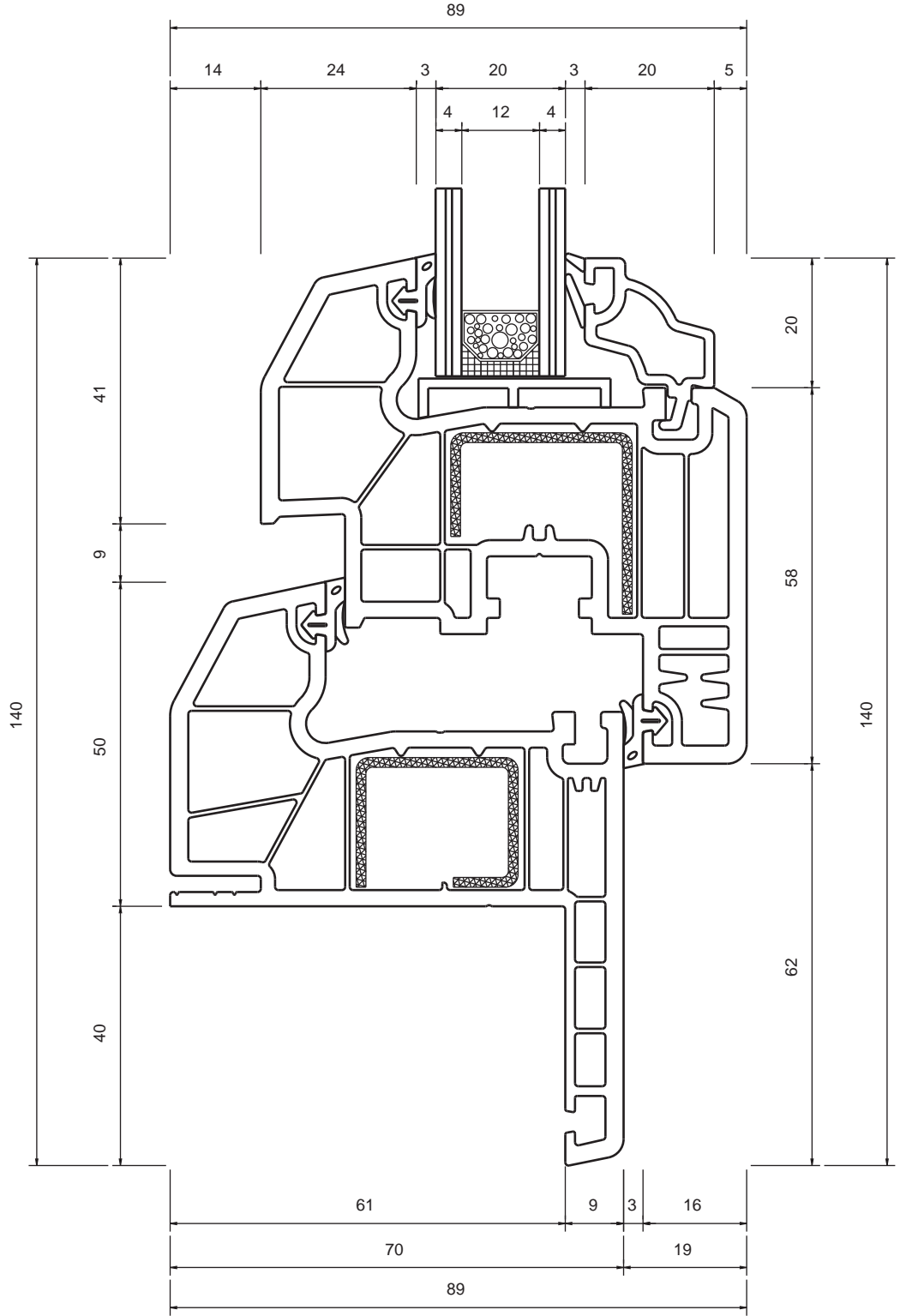

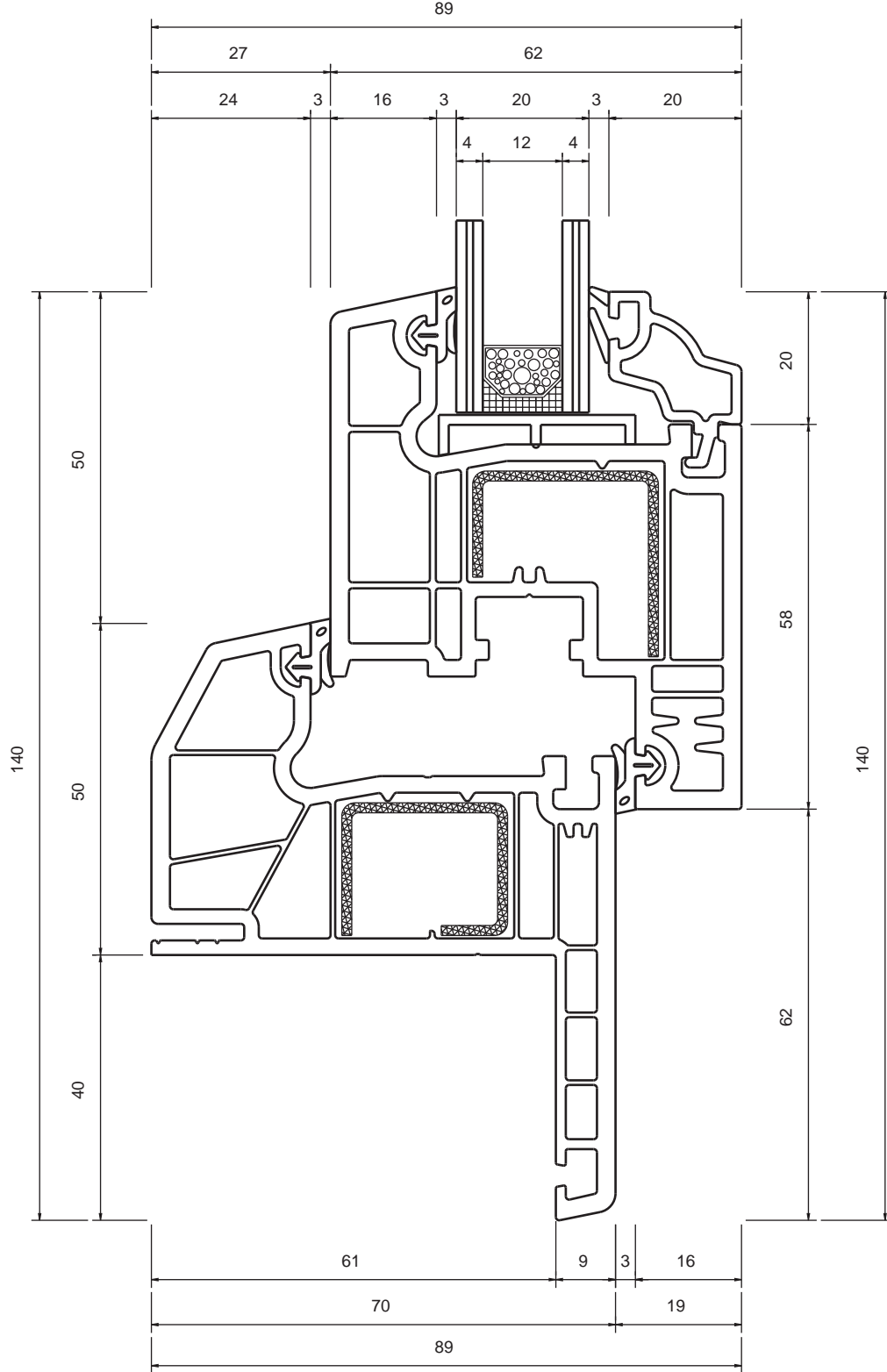
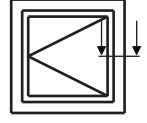

S-705 PERVAZLI KASA & S-624 KANAT BİRLEŞİM DETAYI

S-705 FRAME WITH BORDER & S-624 SASH APPLICATION DETAIL

Ölçek 1/1 Scale



www.mywin.com.tr

BESE METAL ve PLASTİK
teknik dökümanlarda değişiklik
yapma hakkını saklı tutar.
reserves the right to make any
modifications on technical
documents.

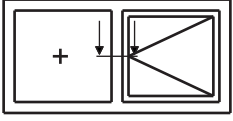

**S-705 ORTA KAYIT & S-705 DAMLALIKLI KANAT
BİRLEŞİM DETAYI**
S-705 MULLION & S-705 DRAINER SASH APPLICATION DETAIL

Ölçek 1/1 Scale



www.mywin.com.tr

BESE METAL ve PLASTİK
teknik dokümanlarda değişiklik
yapma hakkını saklı tutar.
reserves the right to make any
modifications on technical
documents.

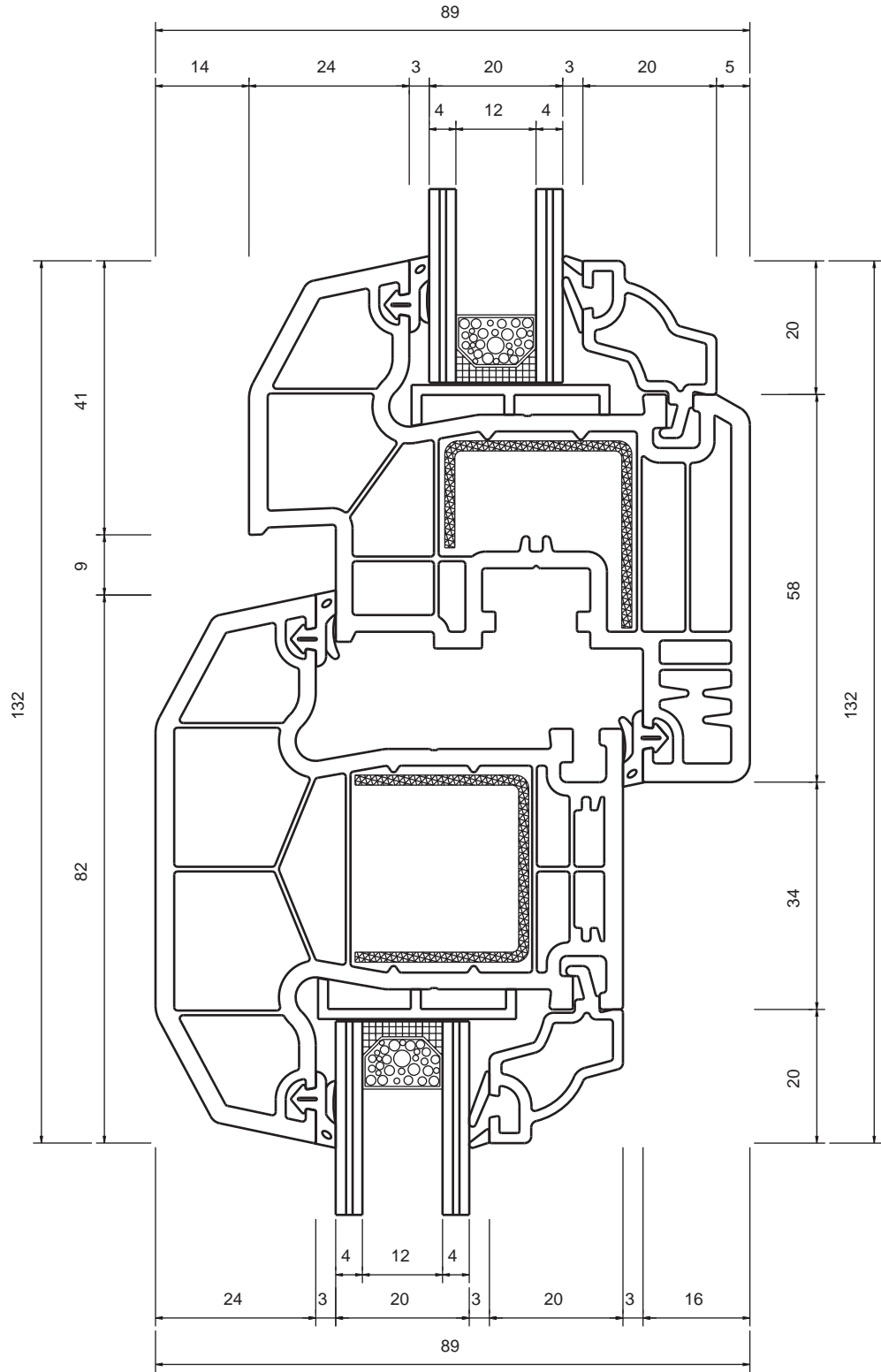

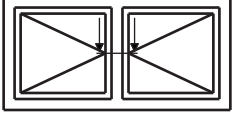

**S-705 DAMLALIKLI KANAT & S-705 ORTA KAYIT &
S-705 DAMLALIKLI KANAT BİRLEŞİM DETAYI**
S-705 DRAINER SASH & S-705 MULLION & S-705 DRAINER SASH
APPLICATION DETAIL

Ölçek 1/1 Scale



www.mywin.com.tr

BESE METAL ve PLASTİK
teknik dökümanlarda değişiklik
yapma hakkını saklı tutar.
reserves the right to make any
modifications on technical
documents.

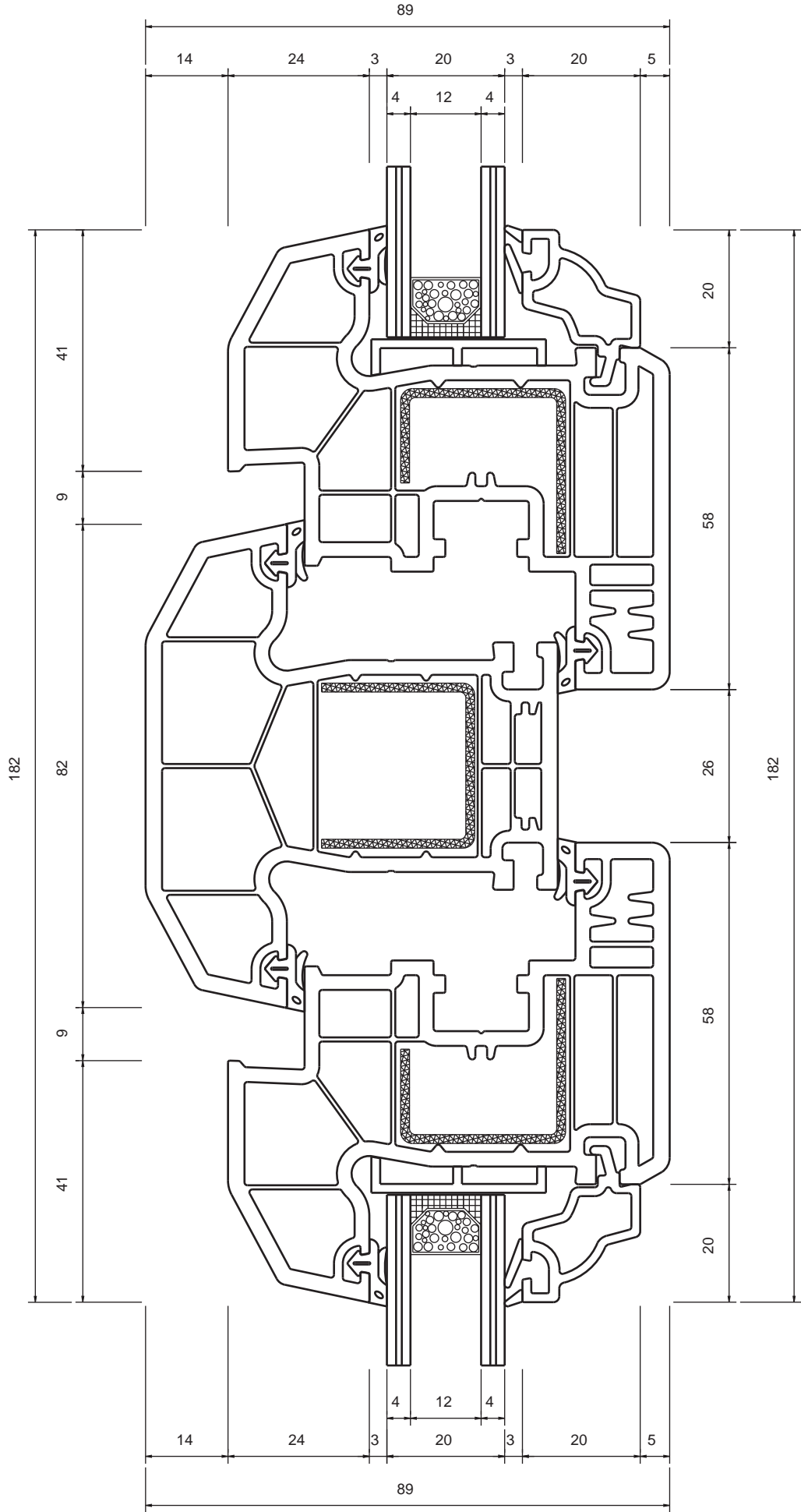

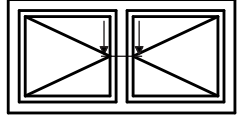
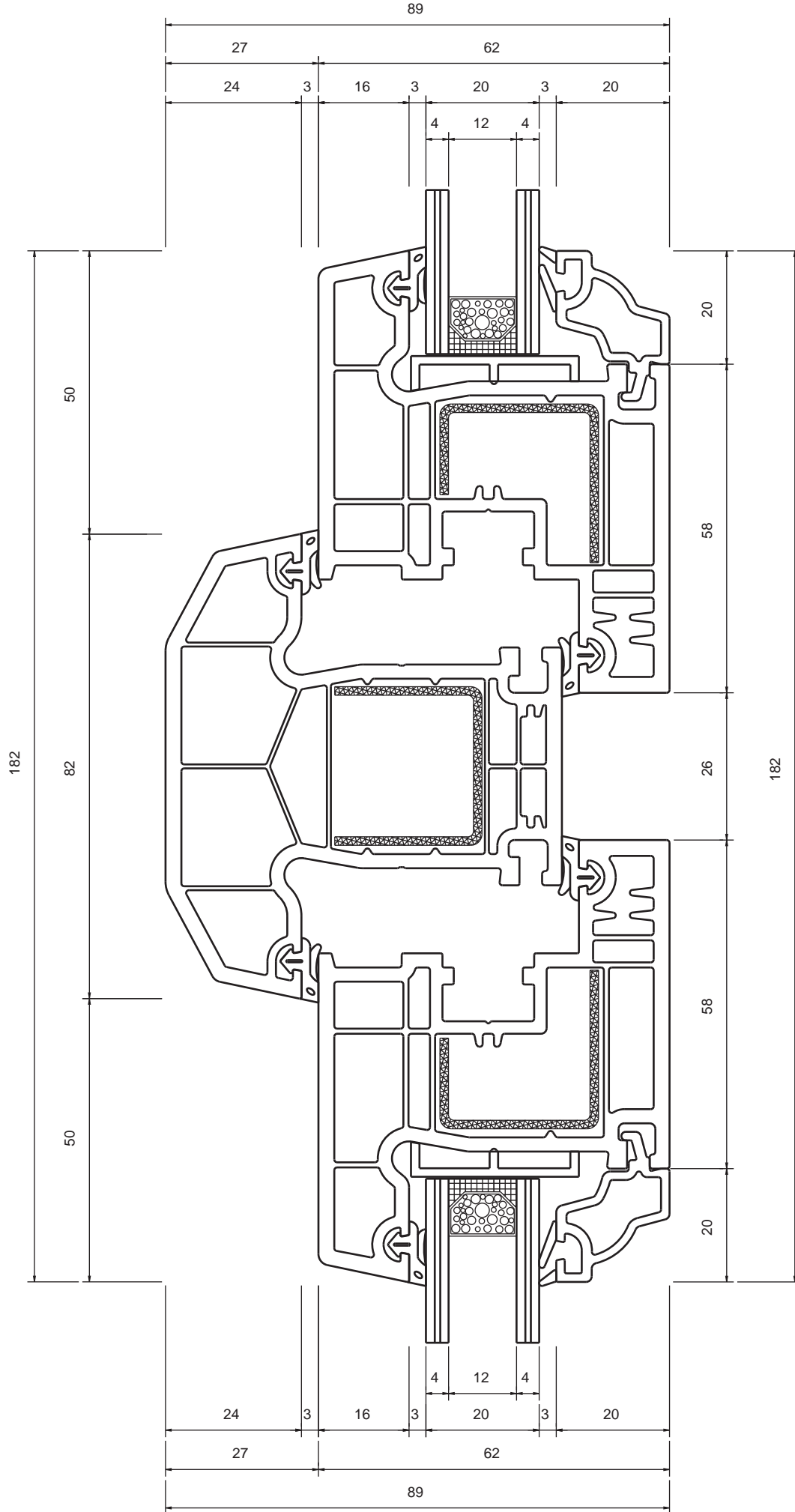

**S-624 KANAT & S-705 ORTA KAYIT & S-624 KANAT
BİRLEŞİM DETAYI**
S-624 SASH & S-705 MULLION & S-624 SASH APPLICATION DETAIL

Ölçek 1/1 Scale



www.mywin.com.tr

BESE METAL ve PLASTİK
teknik dökümanlarda değişiklik
yapma hakkını saklı tutar.
reserves the right to make any
modifications on technical
documents.

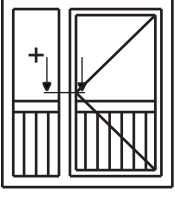

**S-705 ORTA KAYIT & S-624 İÇE AÇILIM KAPI KANAT
BİRLEŞİM DETAYI**
S-705 MULLION & S-624 IN SIDE DOOR SASH APPLICATION DETAIL

Ölçek 1/1 Scale



www.mywin.com.tr

BESE METAL ve PLASTİK
teknik dokümanlarda değişiklik
yapma hakkını saklı tutar.
reserves the right to make any
modifications on technical
documents.

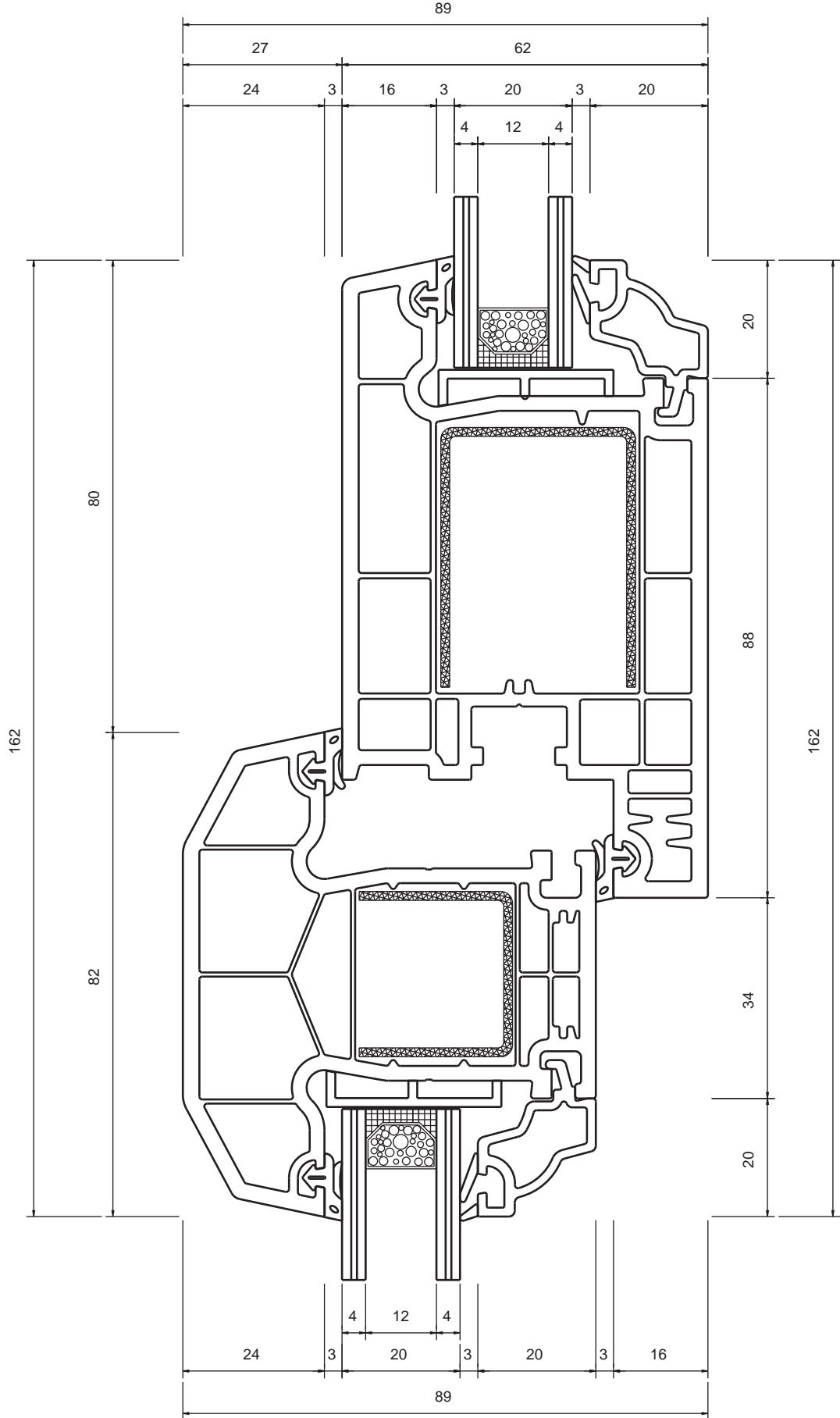

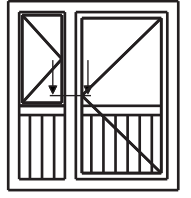
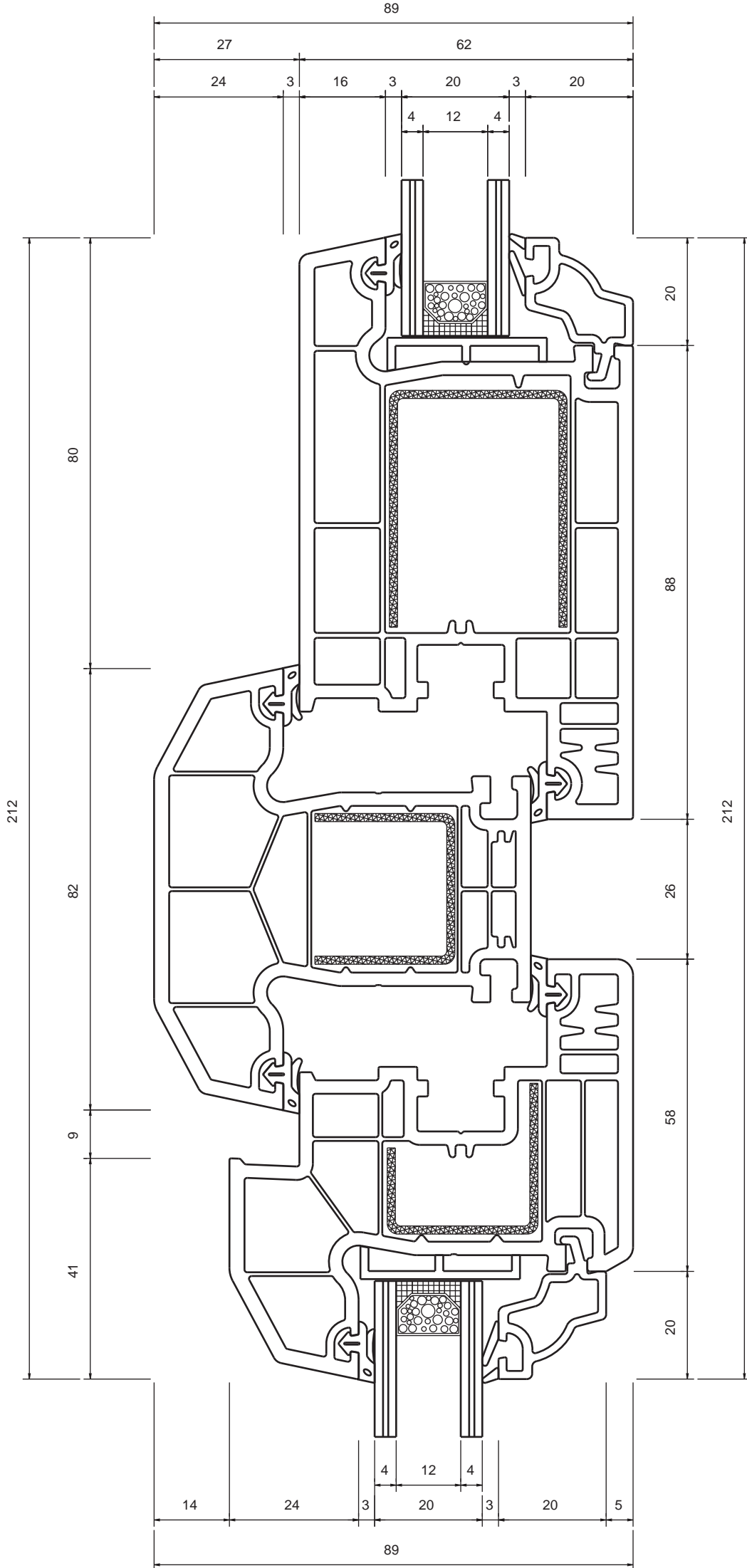

**S-705 DAMLALIKLI KANAT & S-705 ORTA KAYIT &
S-624 İÇE AÇILIM KAPI KANAT BİRLEŞİM DETAYI**
S-705 DRAINER SASH & S-705 MULLION & S-624 IN SIDE DOOR SASH
APPLICATION DETAIL

Ölçek 1/1 Scale



www.mywin.com.tr

BESE METAL ve PLASTİK
teknik dökümanlarda değişiklik
yapma hakkını saklı tutar.
reserves the right to make any
modifications on technical
documents.

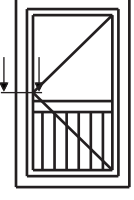

**S-705 KASA & S-624 İÇE AÇILIM KAPI KANAT
BİRLEŞİM DETAYI**
S-705 FRAME & S-624 IN SIDE DOOR SASH APPLICATION DETAIL

Ölçek 1/1 Scale



www.mywin.com.tr

BESE METAL ve PLASTİK
teknik dökümanlarda değişiklik
yapma hakkını saklı tutar.
reserves the right to make any
modifications on technical
documents.

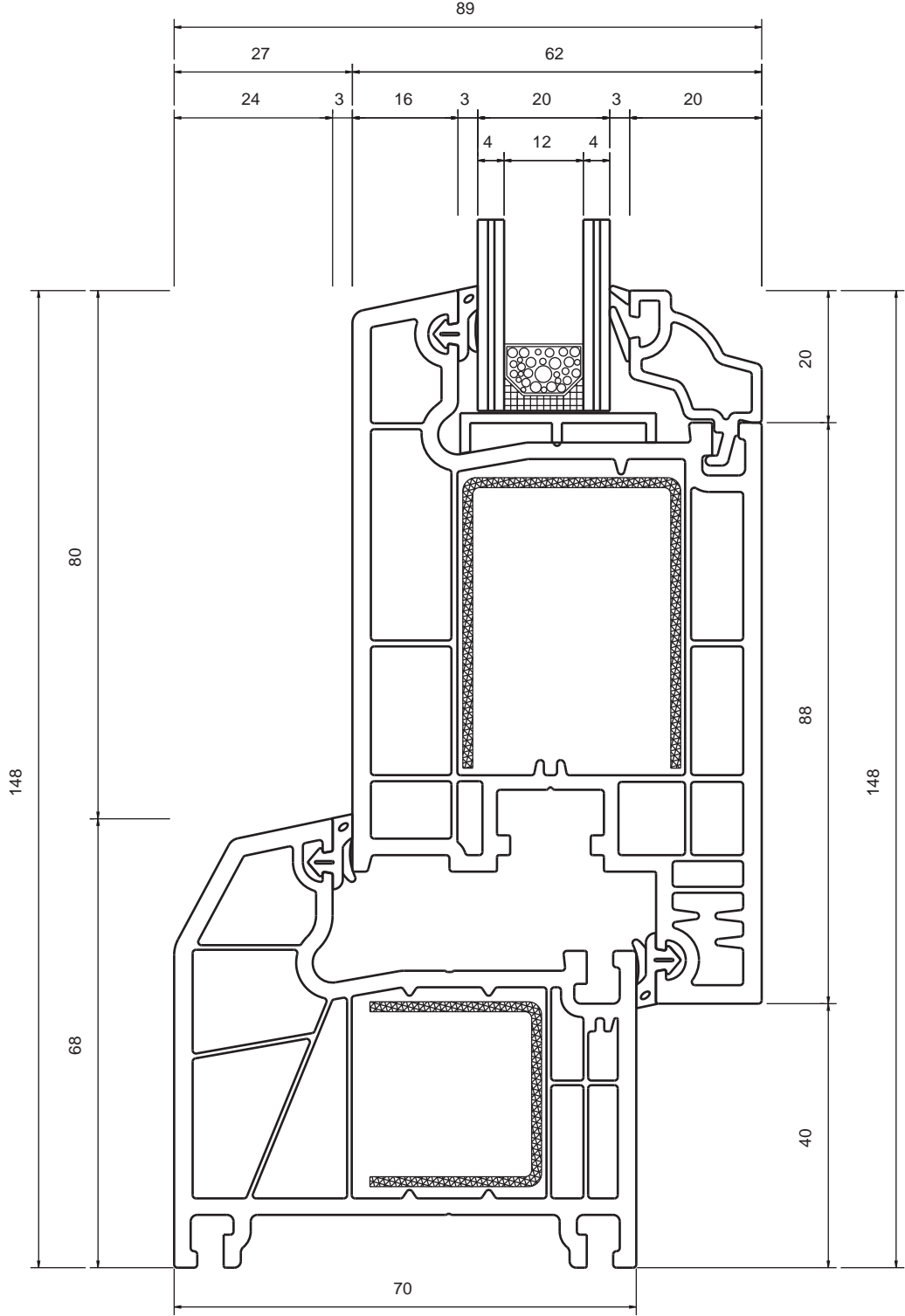

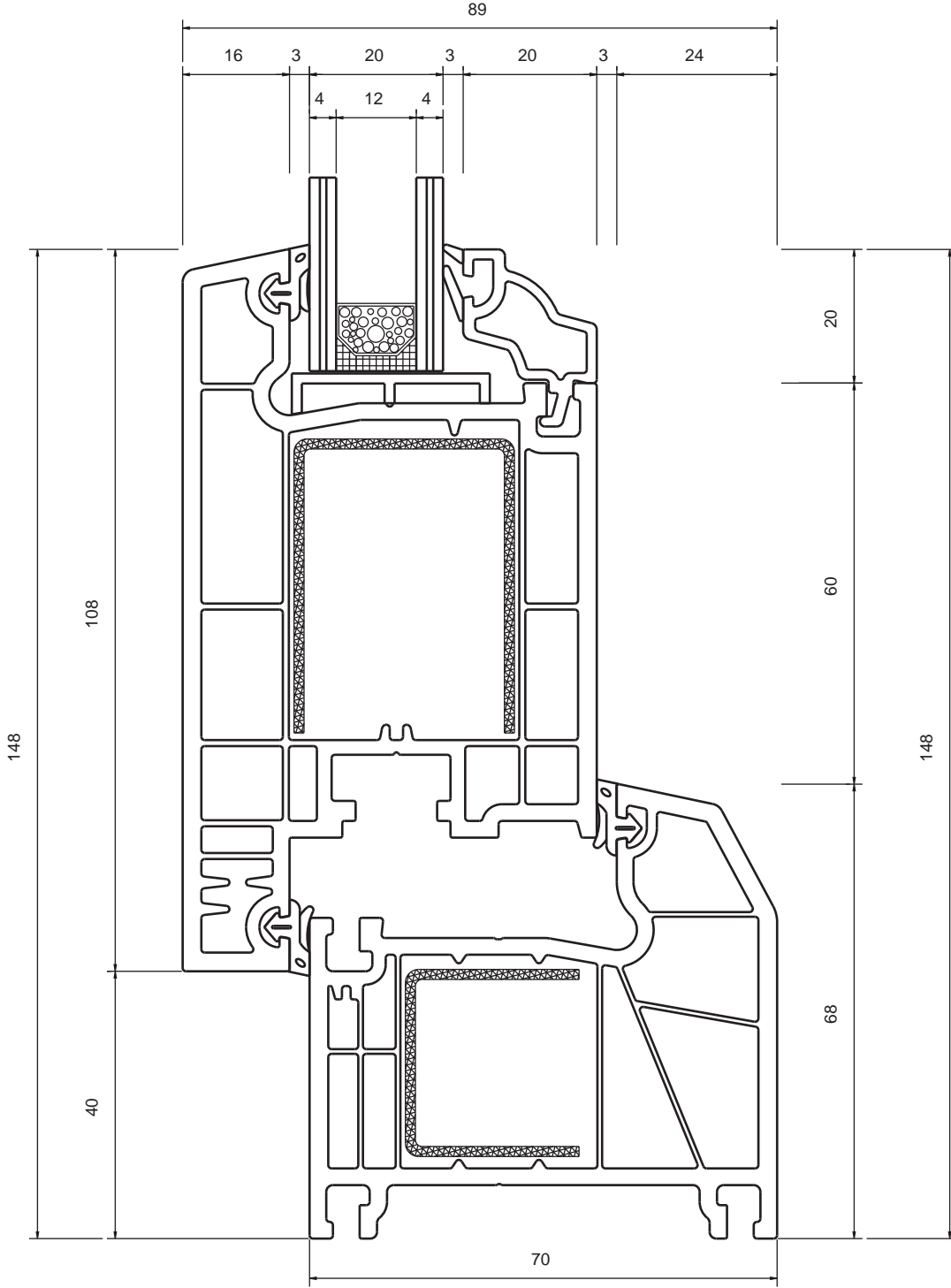
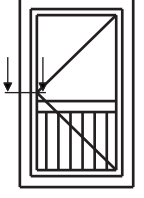

**S-705 KASA & S-624 DİPA AÇILIM KAPI KANAT
BİRLEŞİM DETAYI**
S-705 FRAME & S-624 OUT SIDE DOOR SASH APPLICATION DETAIL

Ölçek 1/1 Scale



www.mywin.com.tr

BESE METAL ve PLASTİK
teknik dökümanlarda değişiklik
yapma hakkını saklı tutar.
reserves the right to make any
modifications on technical
documents.

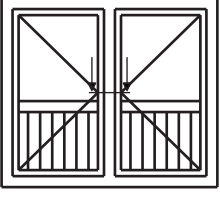

**S-624 İÇE AÇILIM KAPI KANAT & S-705 ORTA KAYIT &
S-624 İÇE AÇILIM KAPI KANAT BİRLEŞİM DETAYI**
S-624 IN SIDE DOOR SASH & S-705 MULLION & S-624 IN SIDE DOOR SASH
APPLICATION DETAIL

Ölçek 1/1 Scale



www.mywin.com.tr

BESE METAL ve PLASTİK
teknik dökümanlarda değişiklik
yapma hakkını saklı tutar.
reserves the right to make any
modifications on technical
documents.

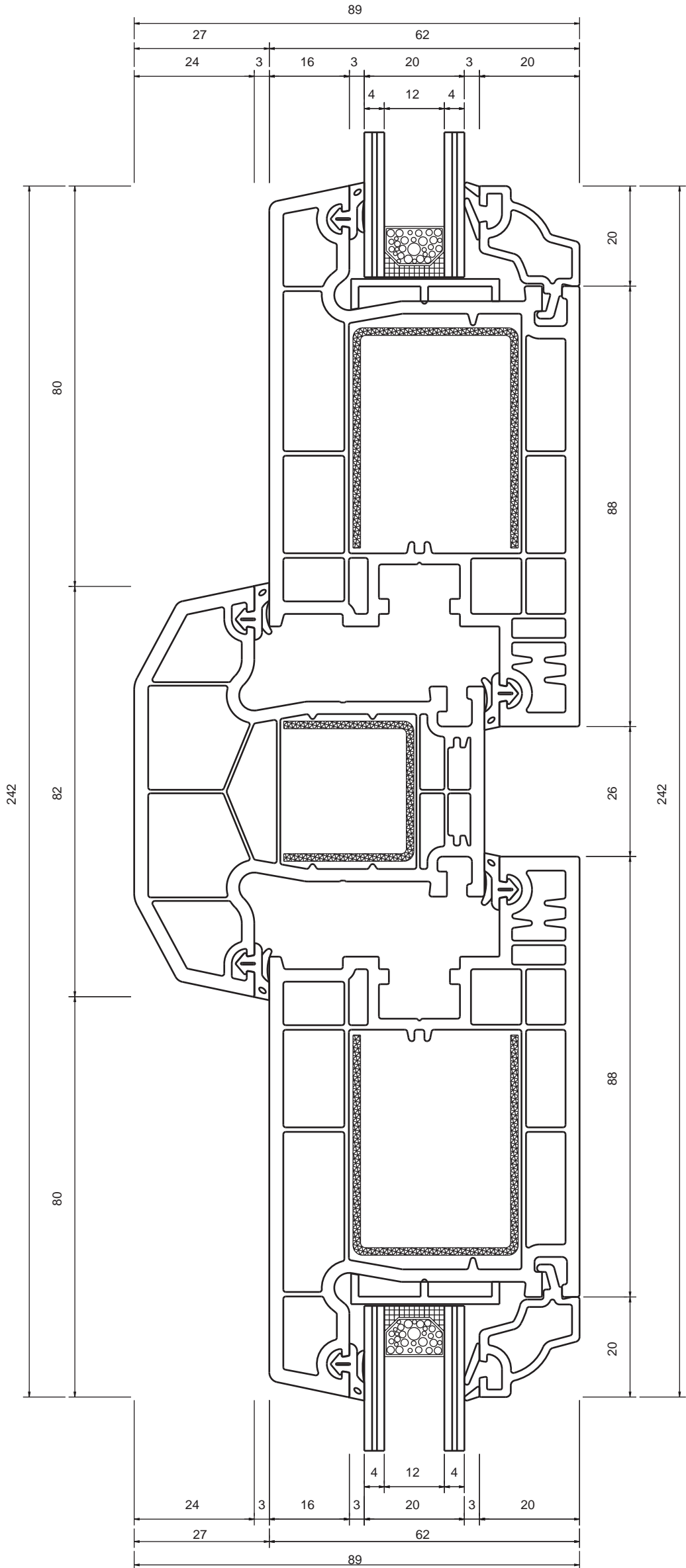

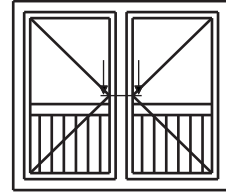
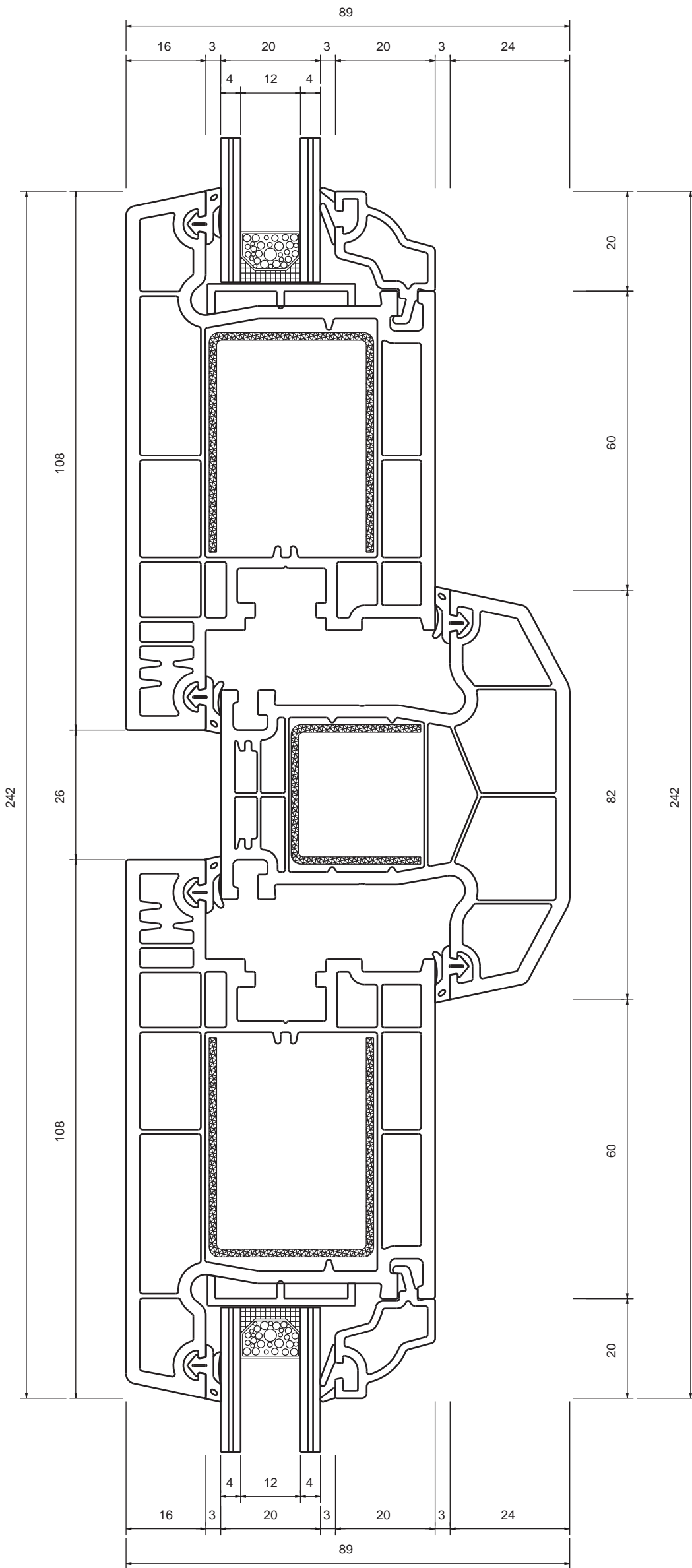

**S-624 DİPA AÇILIM KAPI KANAT & S-705 ORTA KAYIT &
S-624 DİPA AÇILIM KAPI KANAT BİRLEŞİM DETAYI**
S-624 OUT SIDE DOOR SASH & S-705 MULLION &
S-624 OUT SIDE DOOR SASH APPLICATION DETAIL

Ölçek 1/1 Scale



www.mywin.com.tr

BESE METAL ve PLASTİK
teknik dökümanlarda değişiklik
yapma hakkını saklı tutar.
reserves the right to make any
modifications on technical
documents.



**S-705 PERVAZLI KASA & S-624 İÇE AÇILIM KAPI KANAT
BİRLEŞİM DETAYI**
S-705 FRAME WITH & S-624 IN SIDE DOOR SASH APPLICATION DETAIL

Ölçek 1/1 Scale



www.mywin.com.tr

BESE METAL ve PLASTİK
teknik dökümanlarda değişiklik
yapma hakkını saklı tutar.
reserves the right to make any
modifications on technical
documents.

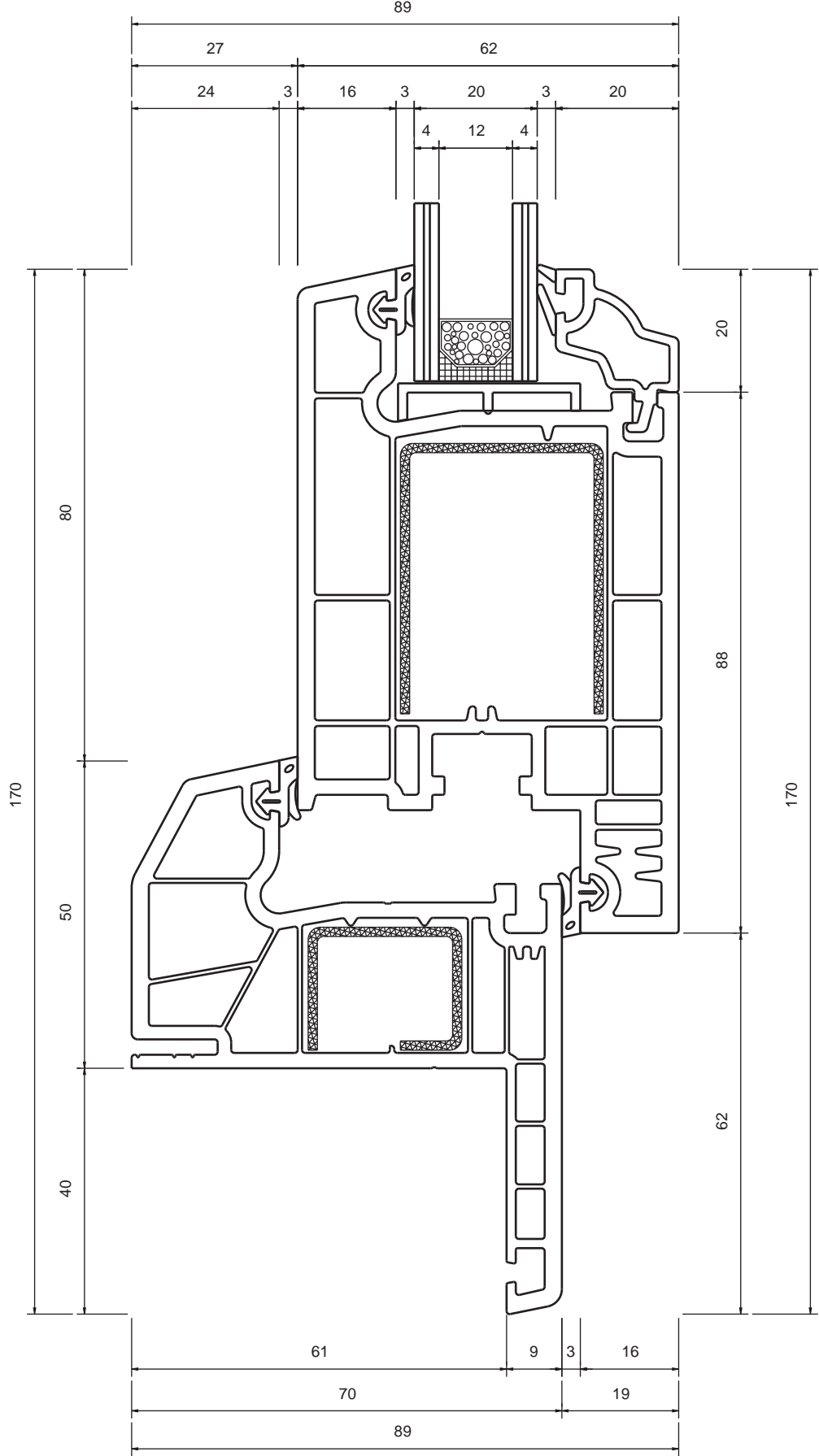

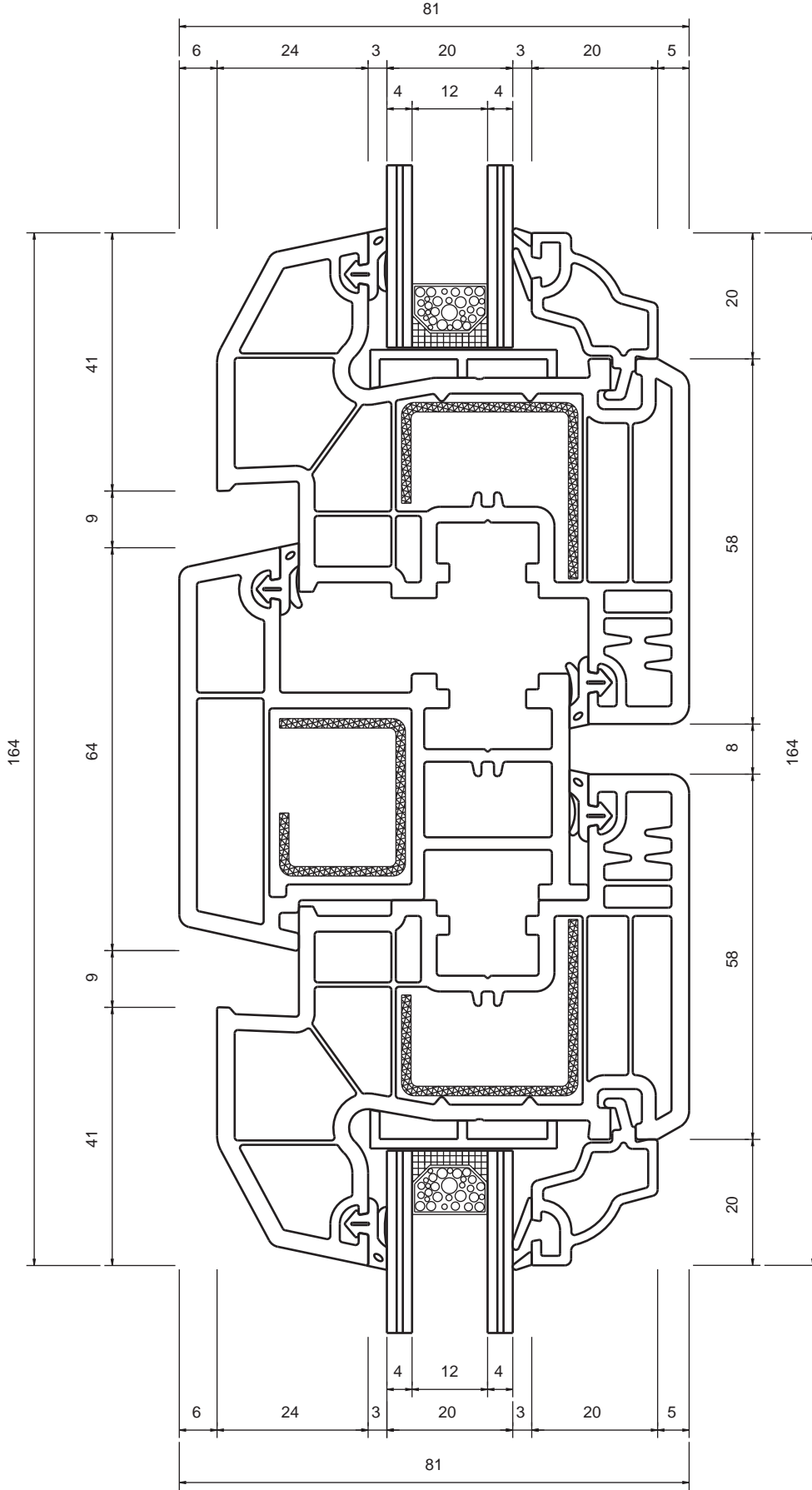
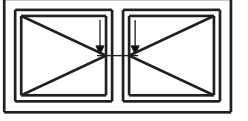

**S-705 DAMLALIKLI KANAT & S-624 HAREKETLİ ORTA KAYIT &
S-705 DAMLALIKLI KANAT BİRLEŞİM DETAYI**
S-705 DRAINER SASH & S-624 MOVING MULLION & S-705 DRAINER SASH
APPLICATION DETAIL

Ölçek 1/1 Scale



www.mywin.com.tr

BESE METAL ve PLASTİK
teknik dökümanlarda değişiklik
yapma hakkını saklı tutar.
reserves the right to make any
modifications on technical
documents.

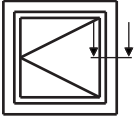

S-705 MONTAJ DETAYI

S-705 MOUNTING DETAIL

Ölçek 1/1 Scale



www.mywin.com.tr

BESE METAL ve PLASTİK
teknik dökümanlarda değişiklik
yapma hakkını saklı tutar.
reserves the right to make any
modifications on technical
documents.

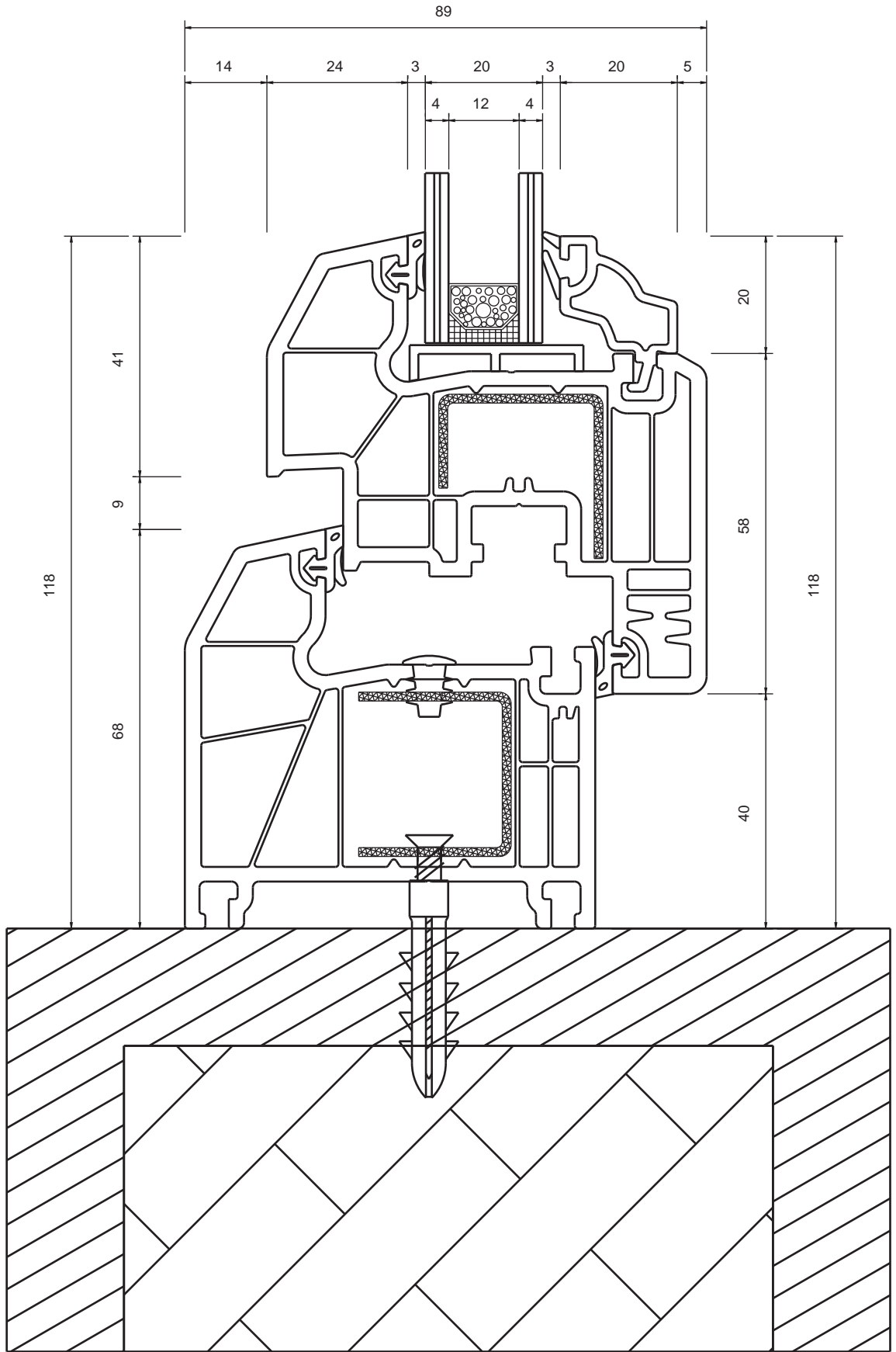

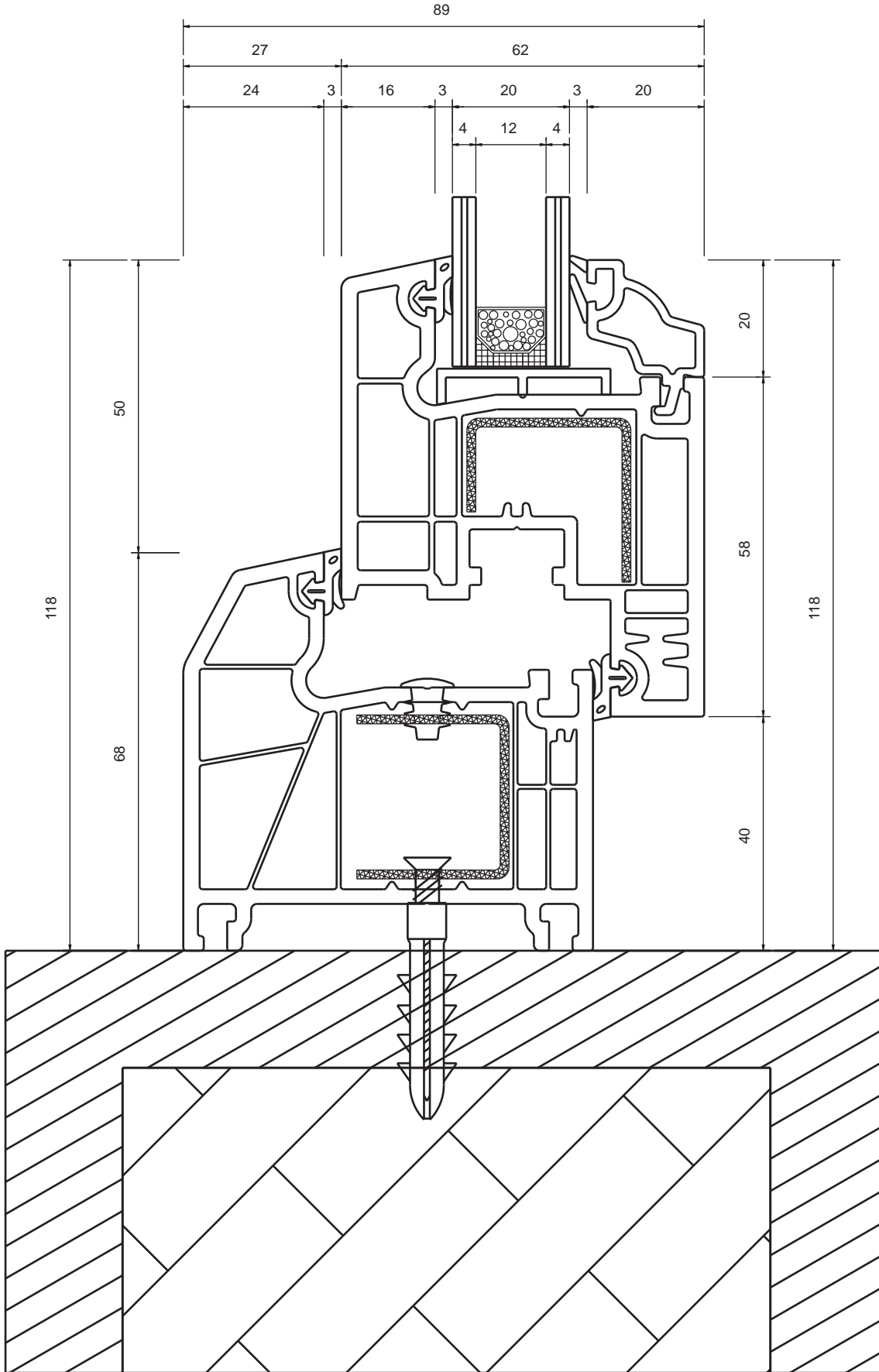
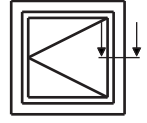

S-705 MONTAJ DETAYI

S-705 MOUNTING DETAIL

Ölçek 1/1 Scale



www.mywin.com.tr

BESE METAL ve PLASTİK
teknik dökümanlarda değişiklik
yapma hakkını saklı tutar.
reserves the right to make any
modifications on technical
documents.

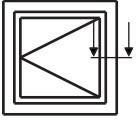

S-705 MONTAJ DETAYI

S-705 MOUNTING DETAIL

Ölçek 1/1 Scale



www.mywin.com.tr

BESE METAL ve PLASTİK
teknik dokümanlarda değişiklik
yapma hakkını saklı tutar.
reserves the right to make any
modifications on technical
documents.

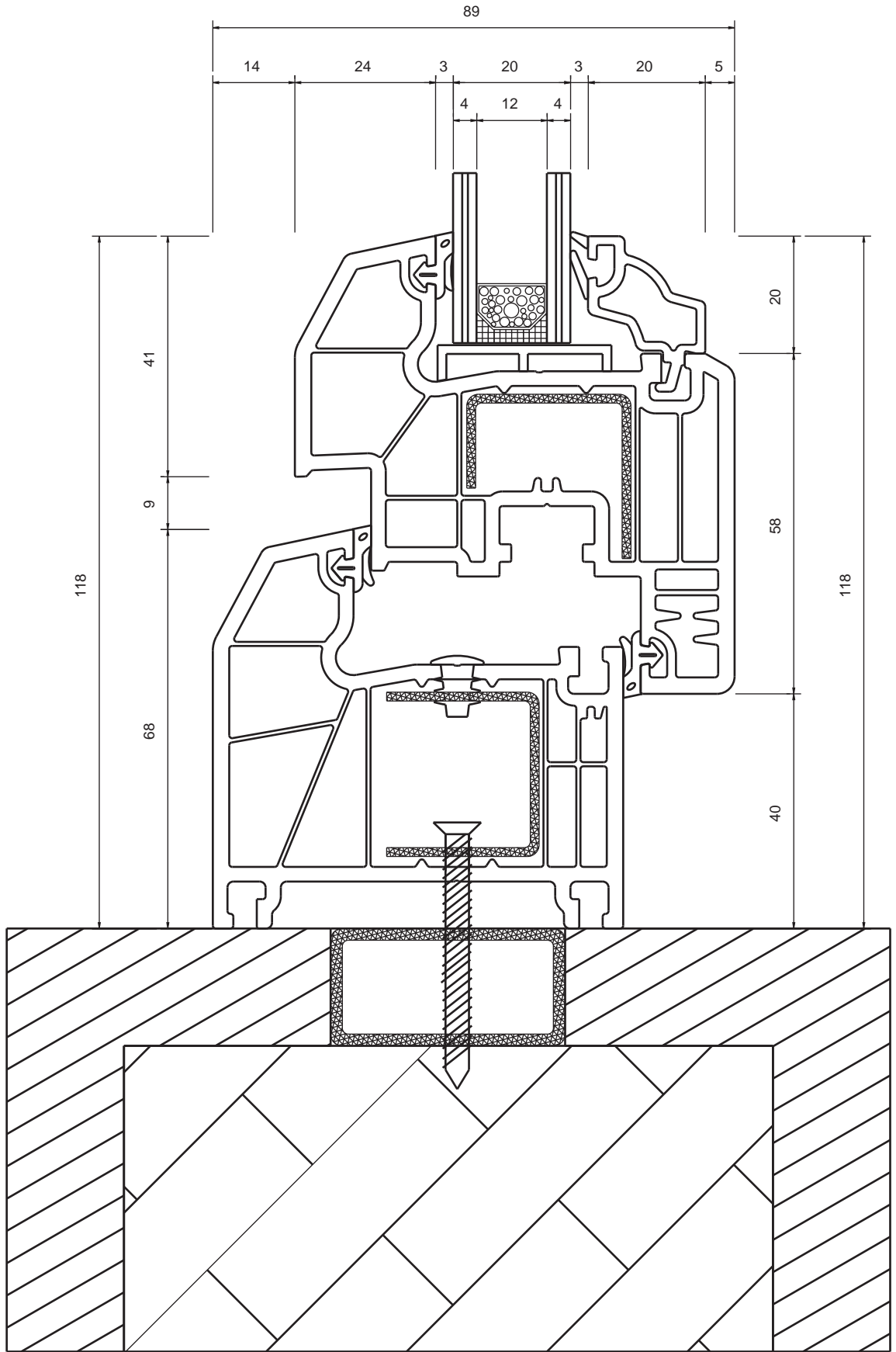

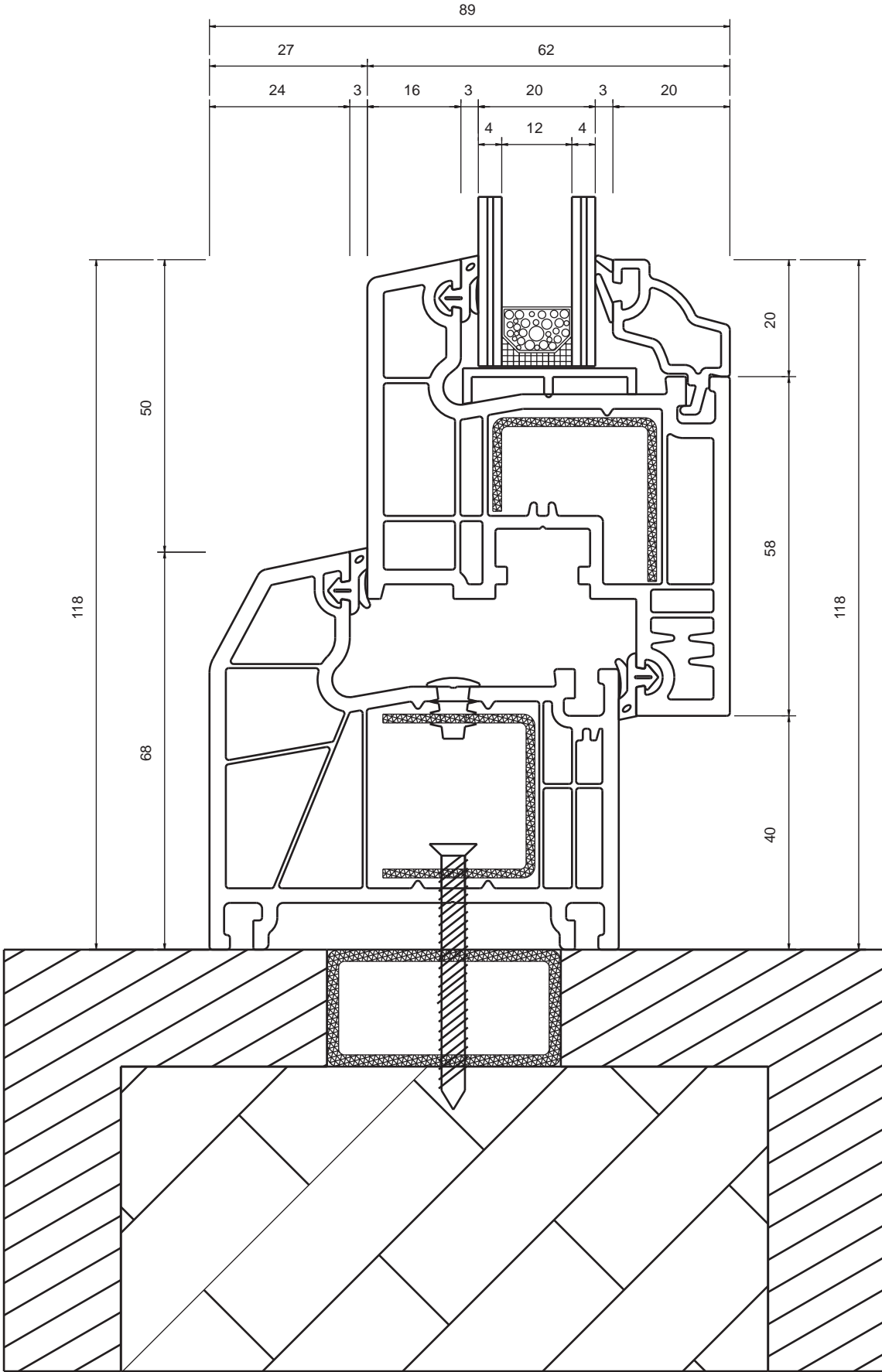
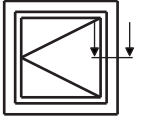

S-705 MONTAJ DETAYI

S-705 MOUNTING DETAIL

Ölçek 1/1 Scale



www.mywin.com.tr

BESE METAL ve PLASTİK
teknik dökümanlarda değişiklik
yapma hakkını saklı tutar.
reserves the right to make any
modifications on technical
documents.

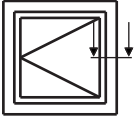

S-705 MONTAJ DETAYI

S-705 MOUNTING DETAIL

Ölçek 1/1 Scale



www.mywin.com.tr

BESE METAL ve PLASTİK
teknik dökümanlarda değişiklik
yapma hakkını saklı tutar.
reserves the right to make any
modifications on technical
documents.

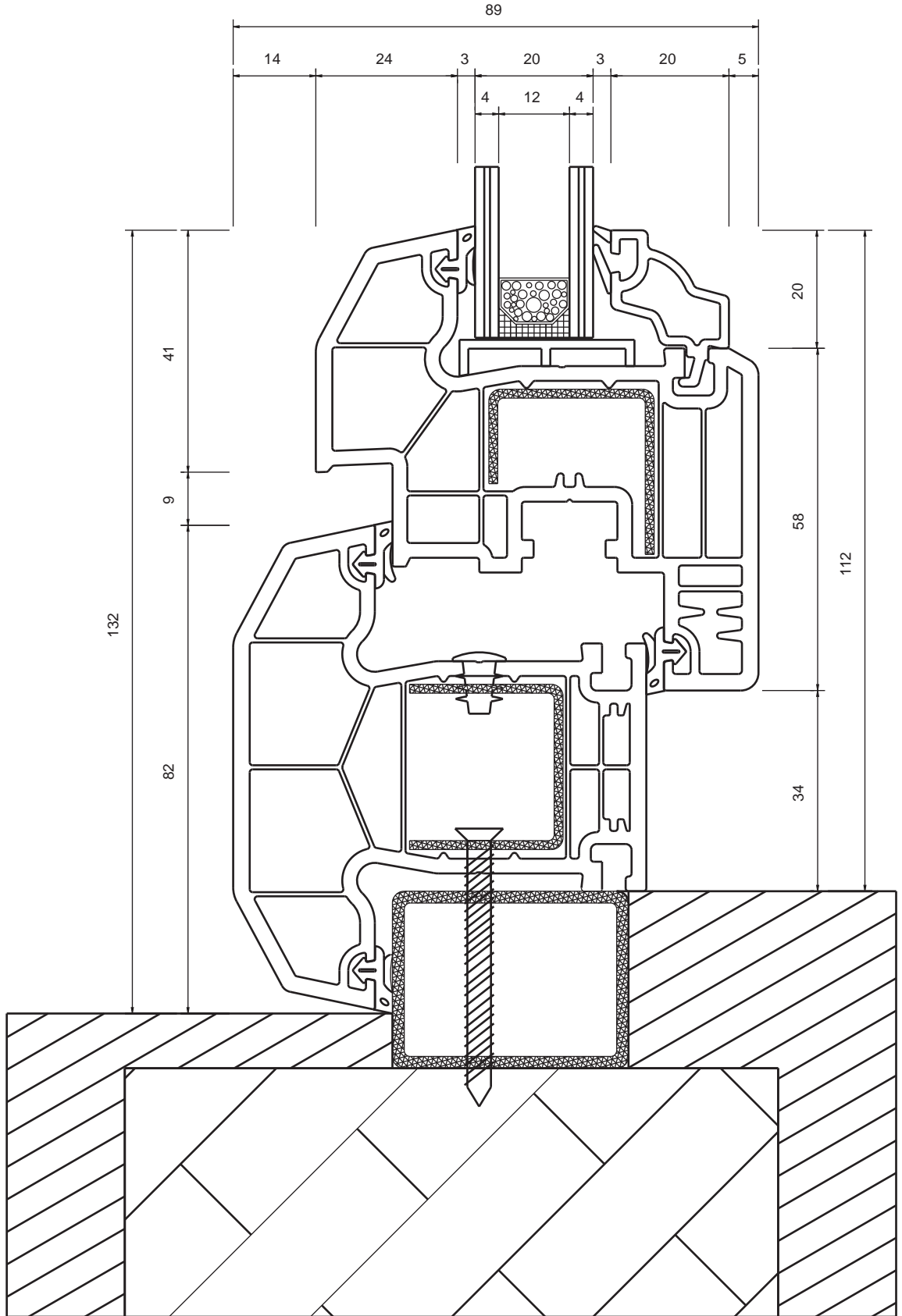

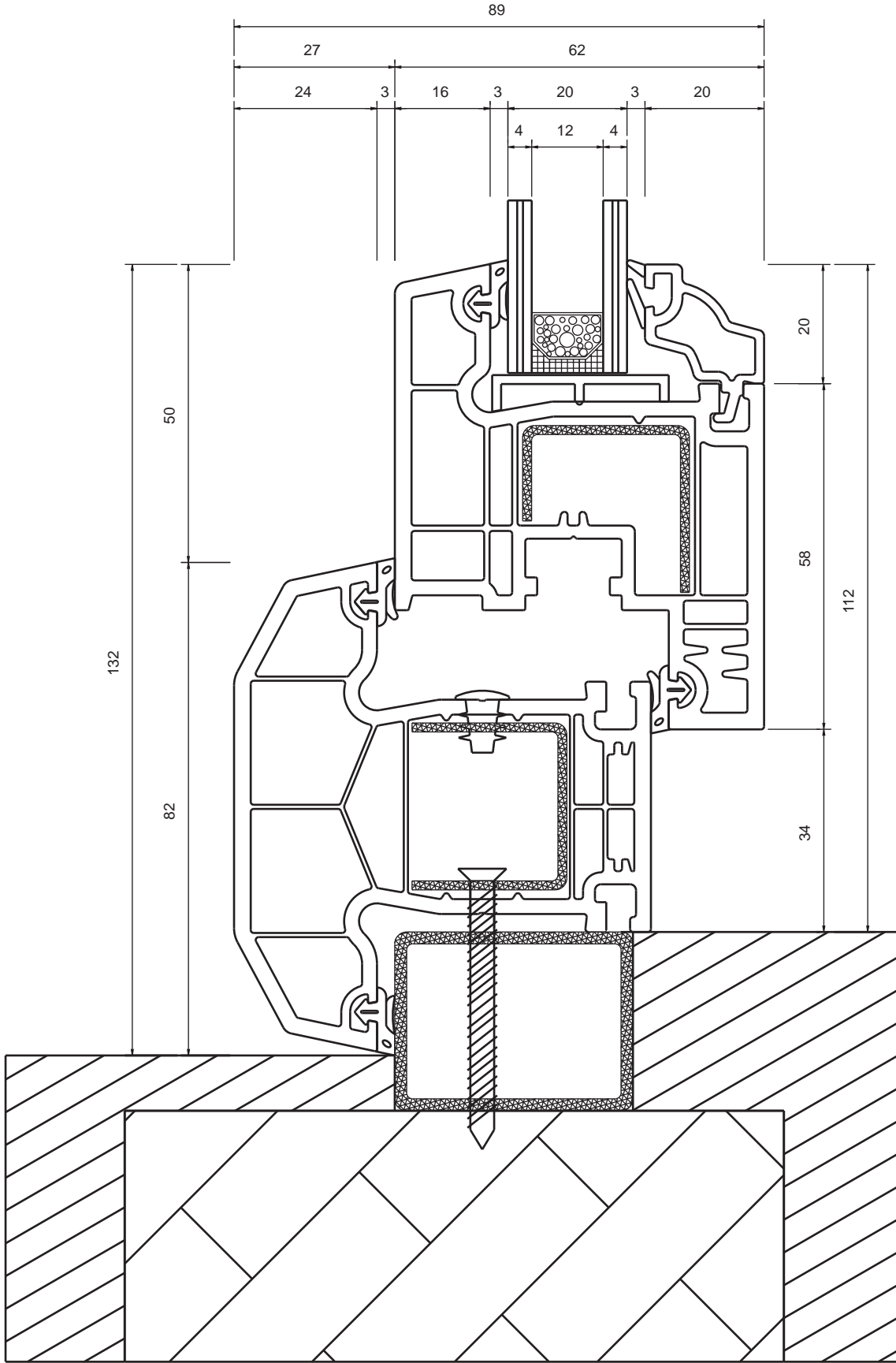
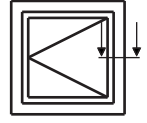

S-705 MONTAJ DETAYI

S-705 MOUNTING DETAIL

Ölçek 1/1 Scale



www.mywin.com.tr

BESE METAL ve PLASTİK
teknik dökümanlarda değişiklik
yapma hakkını saklı tutar.
reserves the right to make any
modifications on technical
documents.

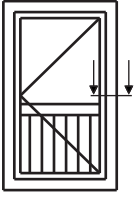

S-705 MONTAJ DETAYI

S-705 MOUNTING DETAIL

Ölçek 1/1 Scale



www.mywin.com.tr

BESE METAL ve PLASTİK
teknik dökümanlarda değişiklik
yapma hakkını saklı tutar.
reserves the right to make any
modifications on technical
documents.

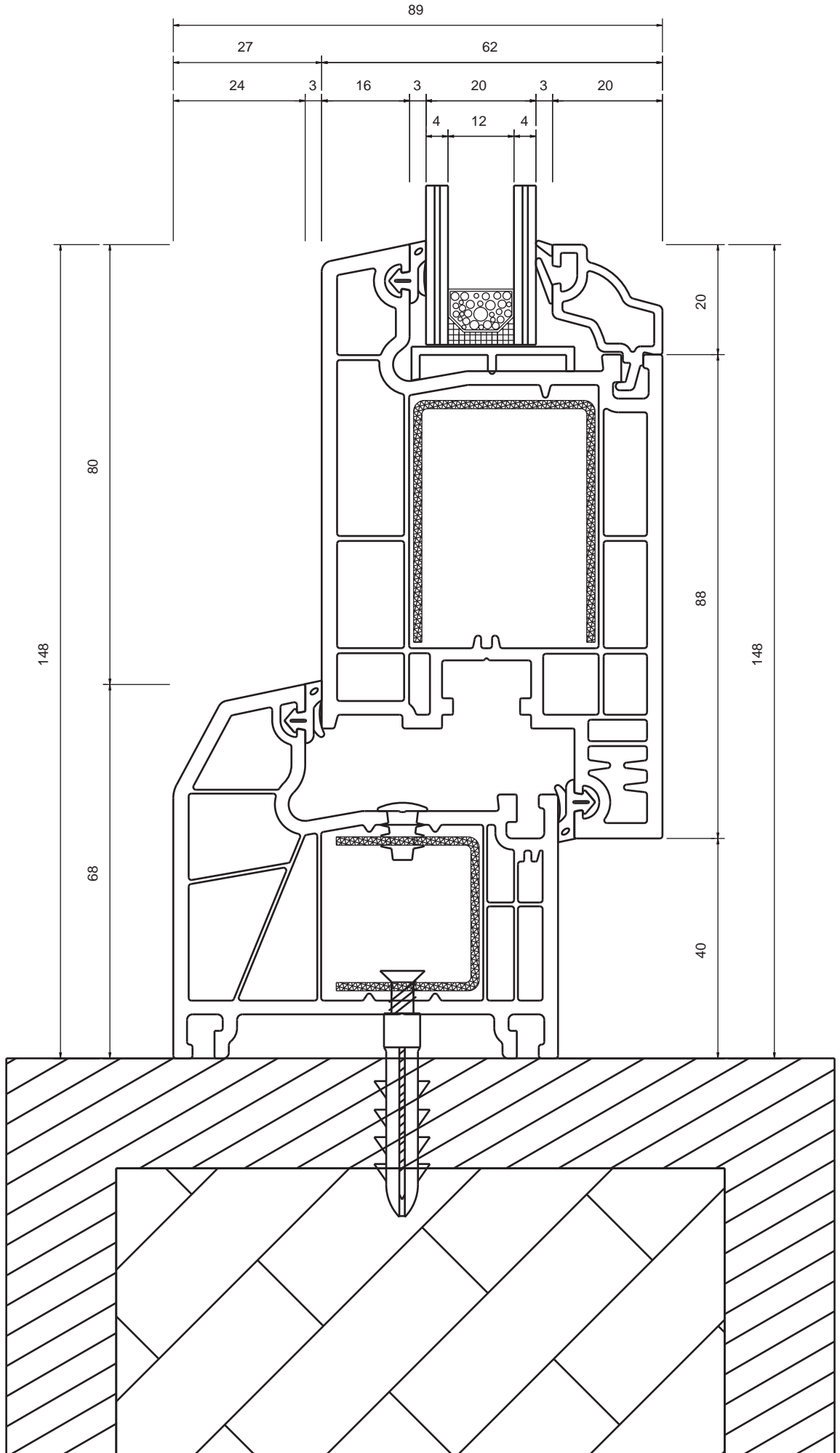

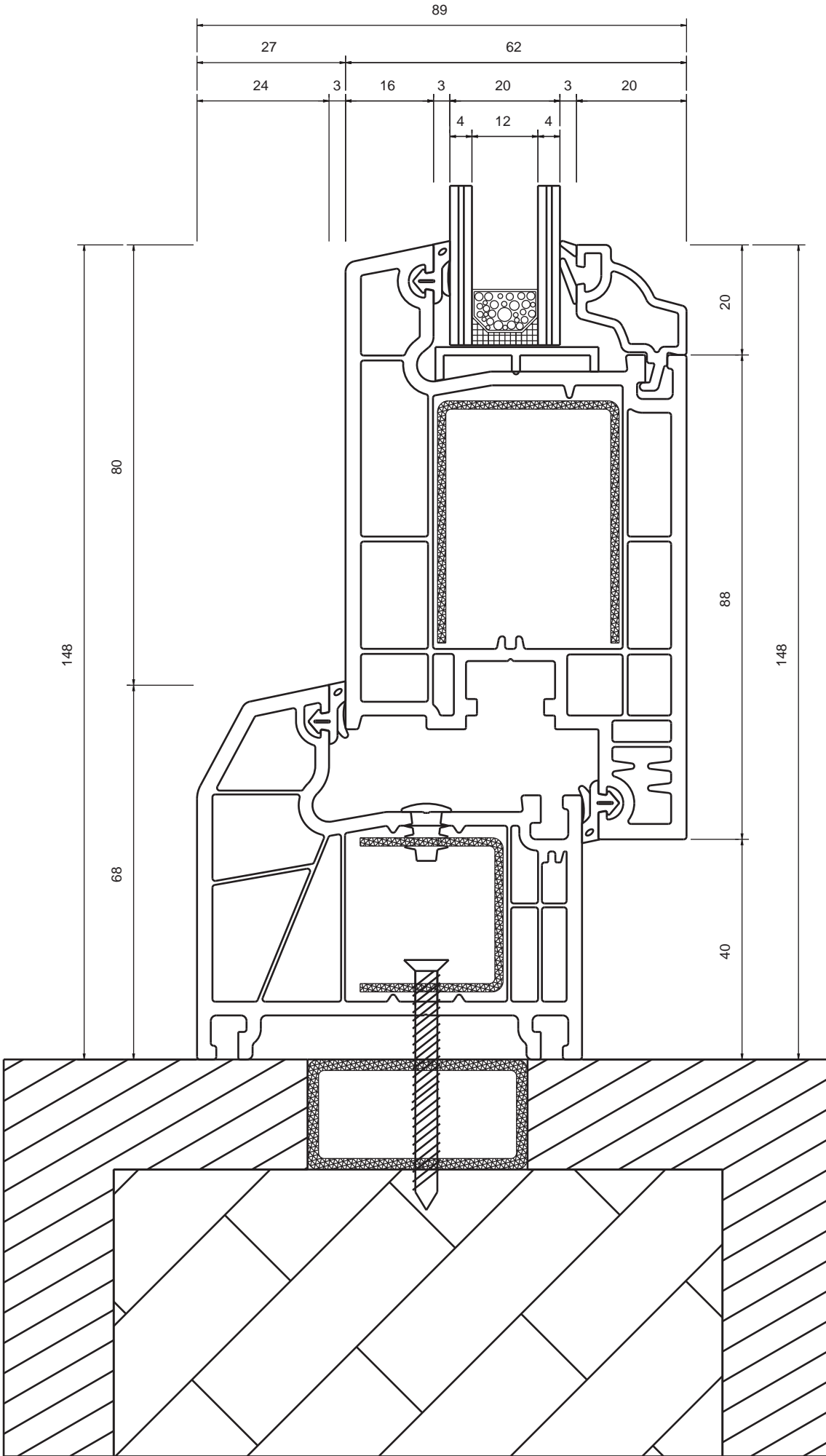
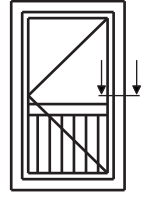

S-705 MONTAJ DETAYI

S-705 MOUNTING DETAIL

Ölçek 1/1 Scale



www.mywin.com.tr

BESE METAL ve PLASTİK
teknik dökümanlarda değişiklik
yapma hakkını saklı tutar.
reserves the right to make any
modifications on technical
documents.

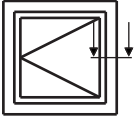

S-705 MONTAJ DETAYI

S-705 MOUNTING DETAIL

Ölçek 1/1 Scale



www.mywin.com.tr

BESE METAL ve PLASTİK
teknik dökümanlarda değişiklik
yapma hakkını saklı tutar.
reserves the right to make any
modifications on technical
documents.

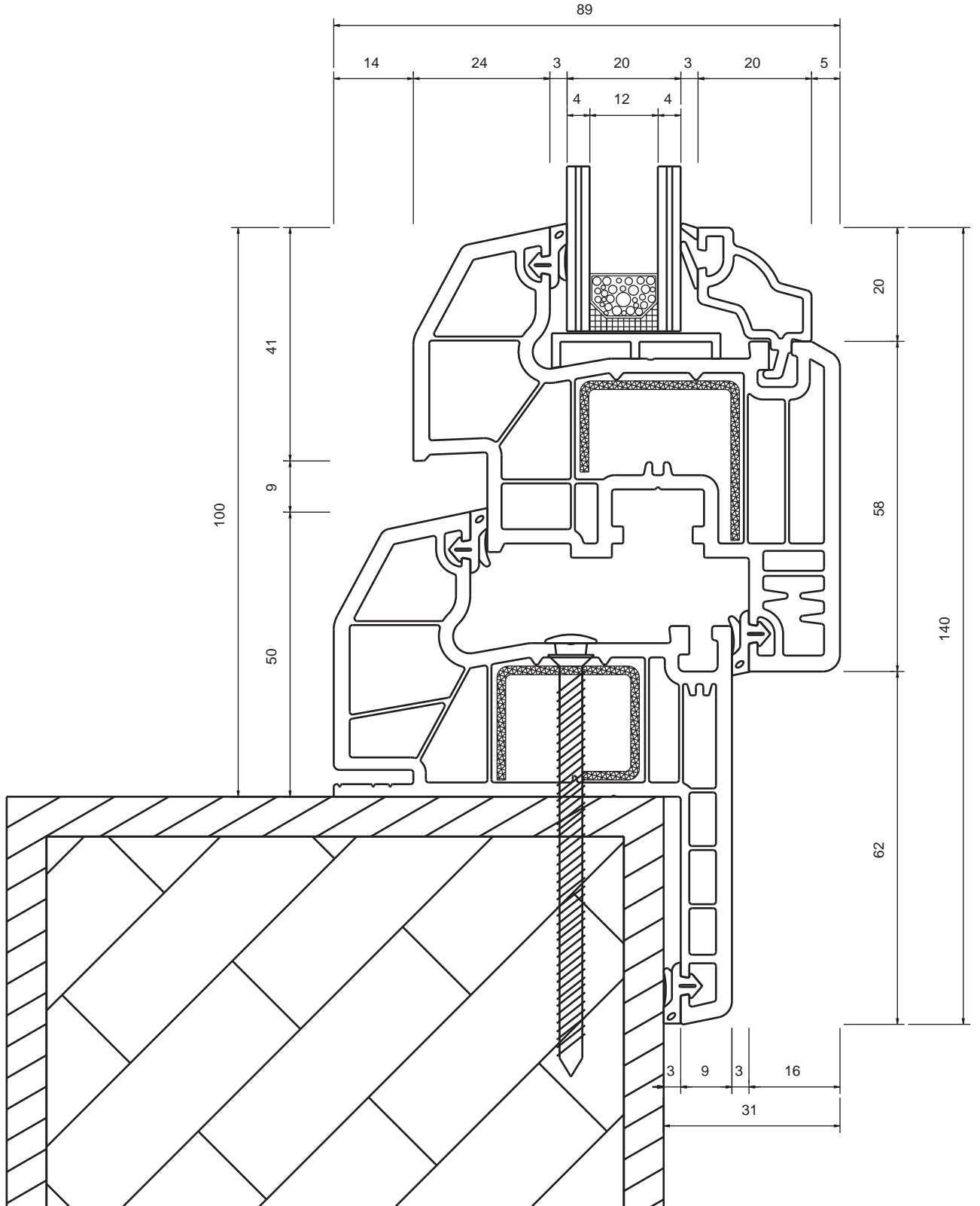

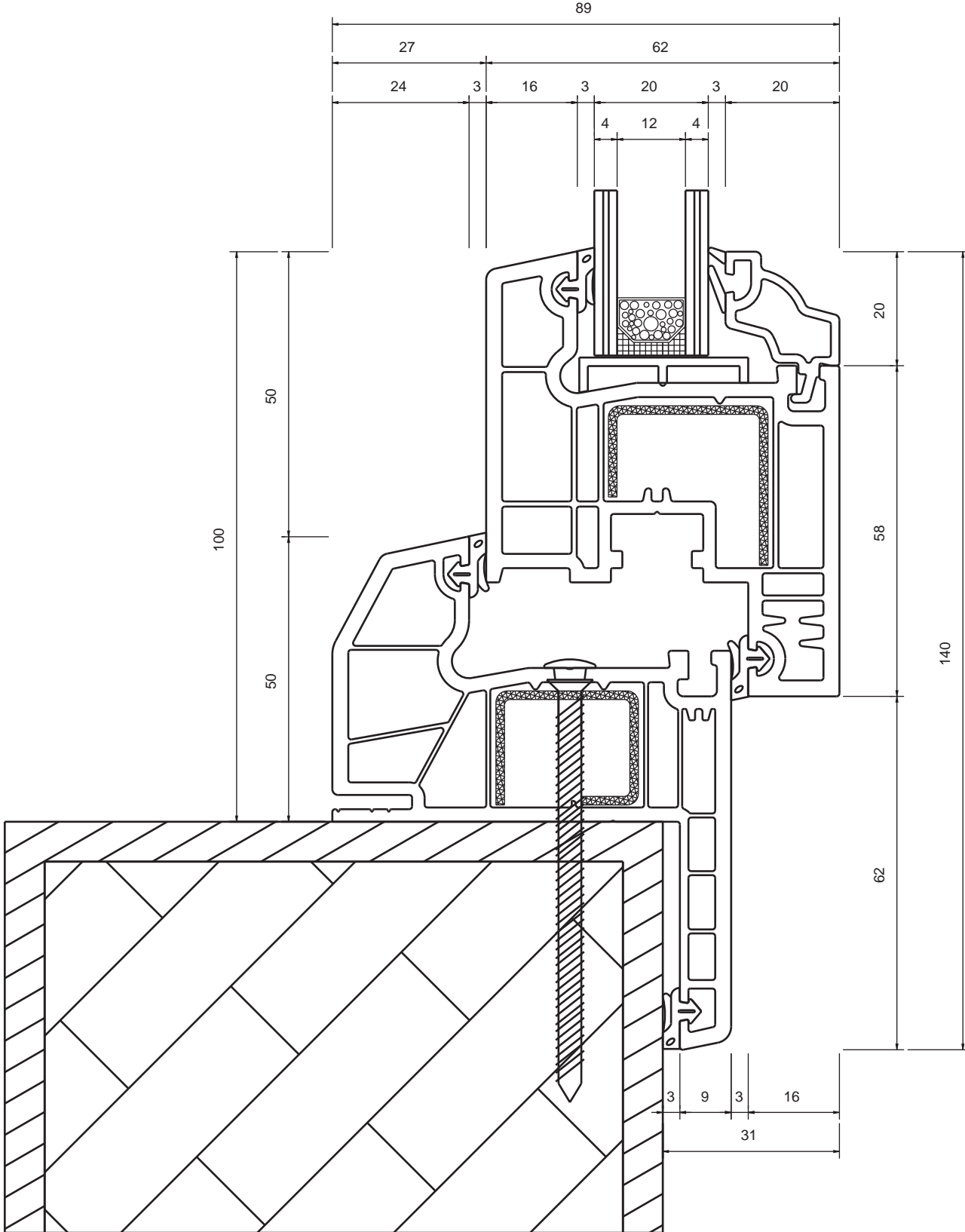
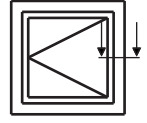

S-705 MONTAJ DETAYI S-705 MOUNTING DETAIL

Ölçek 1/1 Scale



www.mywin.com.tr

BESE METAL ve PLASTİK
teknik dökümanlarda değişiklik
yapma hakkını saklı tutar.
reserves the right to make any
modifications on technical
documents.

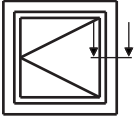

S-705 MONTAJ DETAYI

S-705 MOUNTING DETAIL

Ölçek 1/1 Scale



www.mywin.com.tr

BESE METAL ve PLASTİK
teknik dokümanlarda değişiklik
yapma hakkını saklı tutar.
reserves the right to make any
modifications on technical
documents.

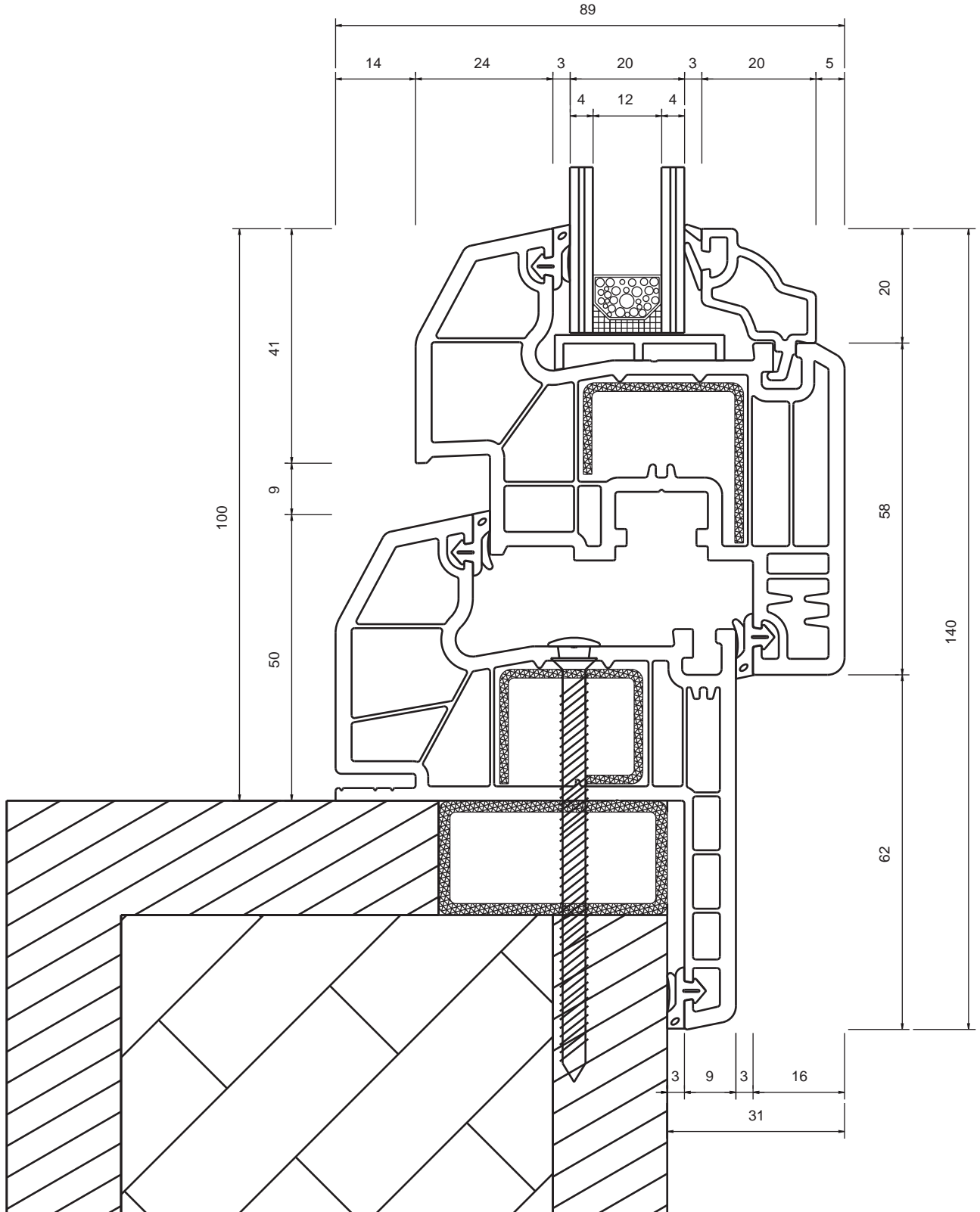

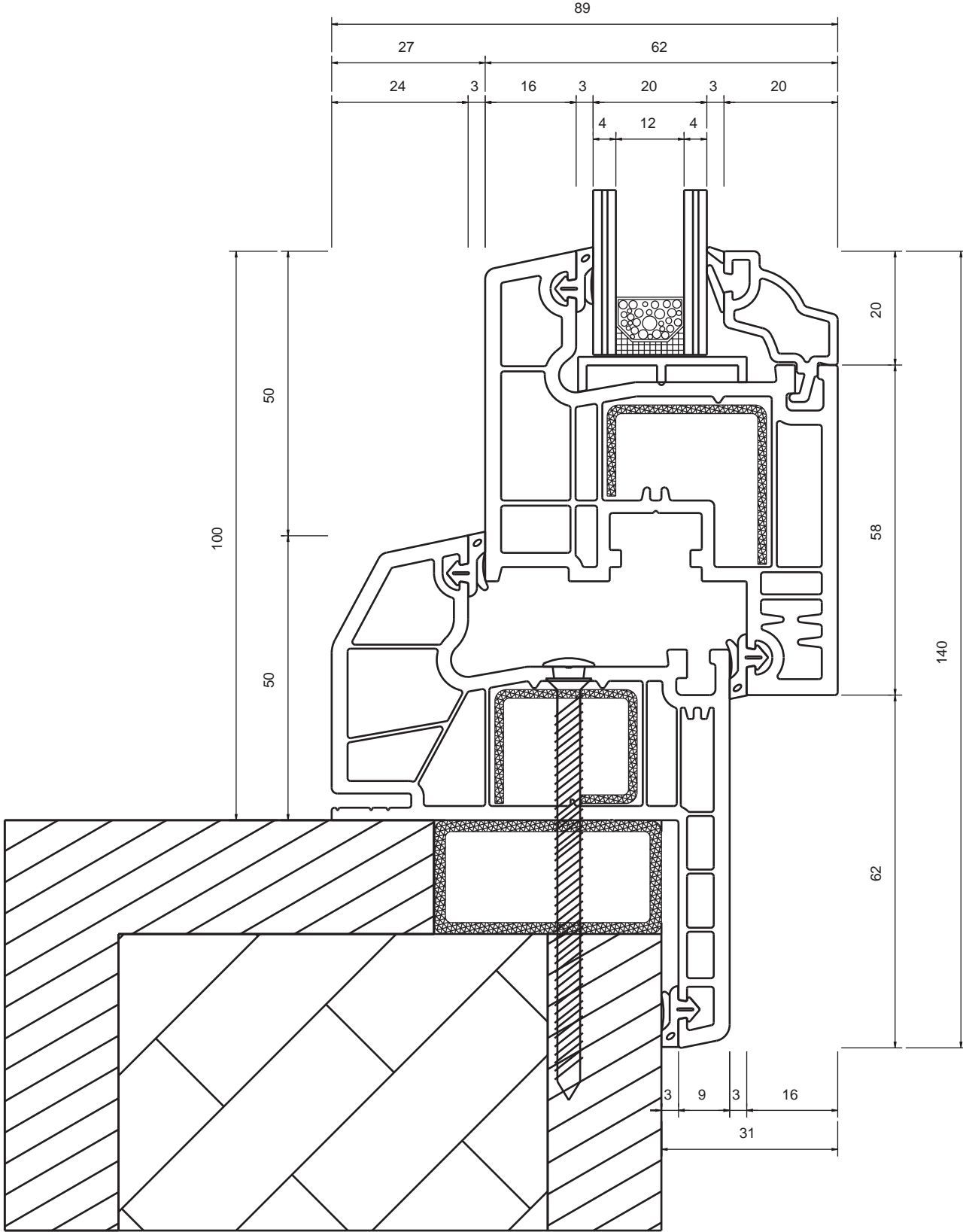
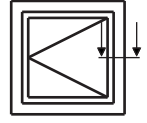

S-705 MONTAJ DETAYI

S-705 MOUNTING DETAIL

Ölçek 1/1 Scale



PVC Window & Door Systems

www.mywin.com.tr

BESE METAL ve PLASTİK
teknik dökümanlarda değişiklik
yapma hakkını saklı tutar.
reserves the right to make any
modifications on technical
documents.

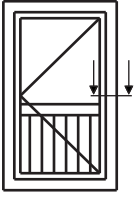

S-705 MONTAJ DETAYI

S-705 MOUNTING DETAIL

Ölçek 1/1 Scale



PVC Window & Door Systems

www.mywin.com.tr

BESE METAL ve PLASTİK
teknik dokümanlarda değişiklik
yapma hakkını saklı tutar.
reserves the right to make any
modifications on technical
documents.

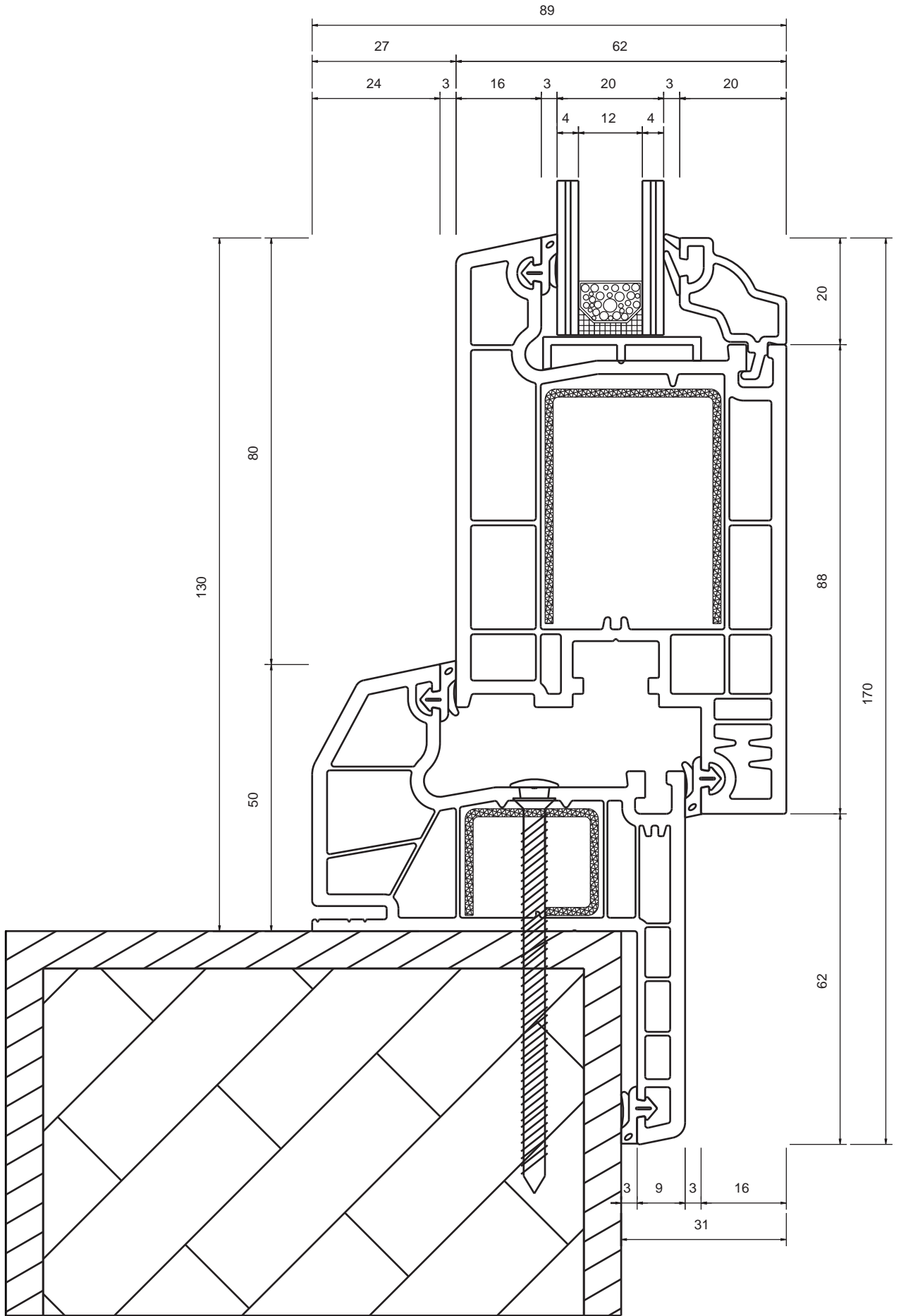

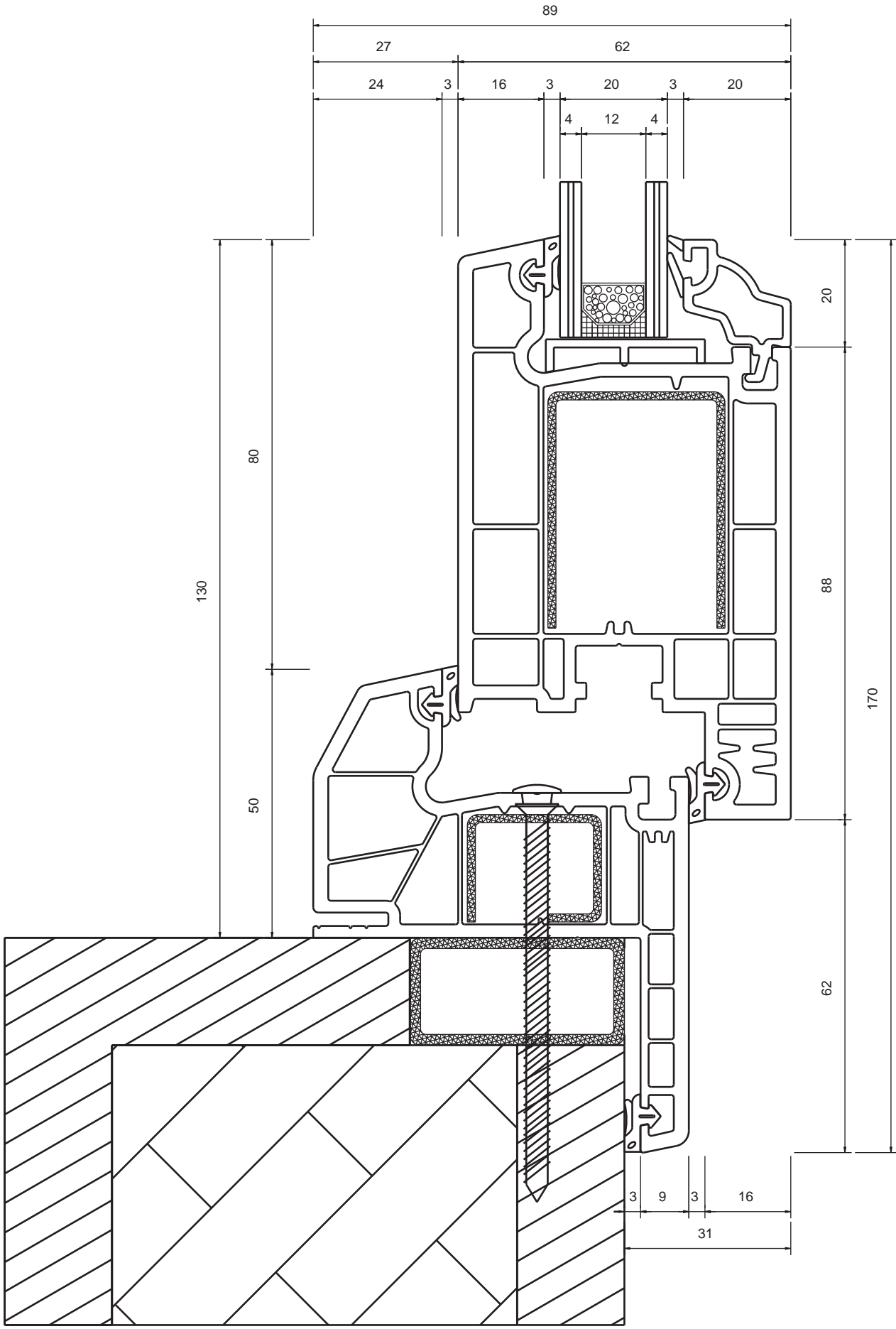
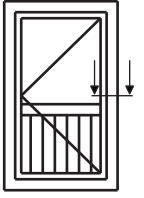

S-705 MONTAJ DETAYI

S-705 MOUNTING DETAIL

Ölçek 1/1 Scale



www.mywin.com.tr

BESE METAL ve PLASTİK
teknik dökümanlarda değişiklik
yapma hakkını saklı tutar.
reserves the right to make any
modifications on technical
documents.

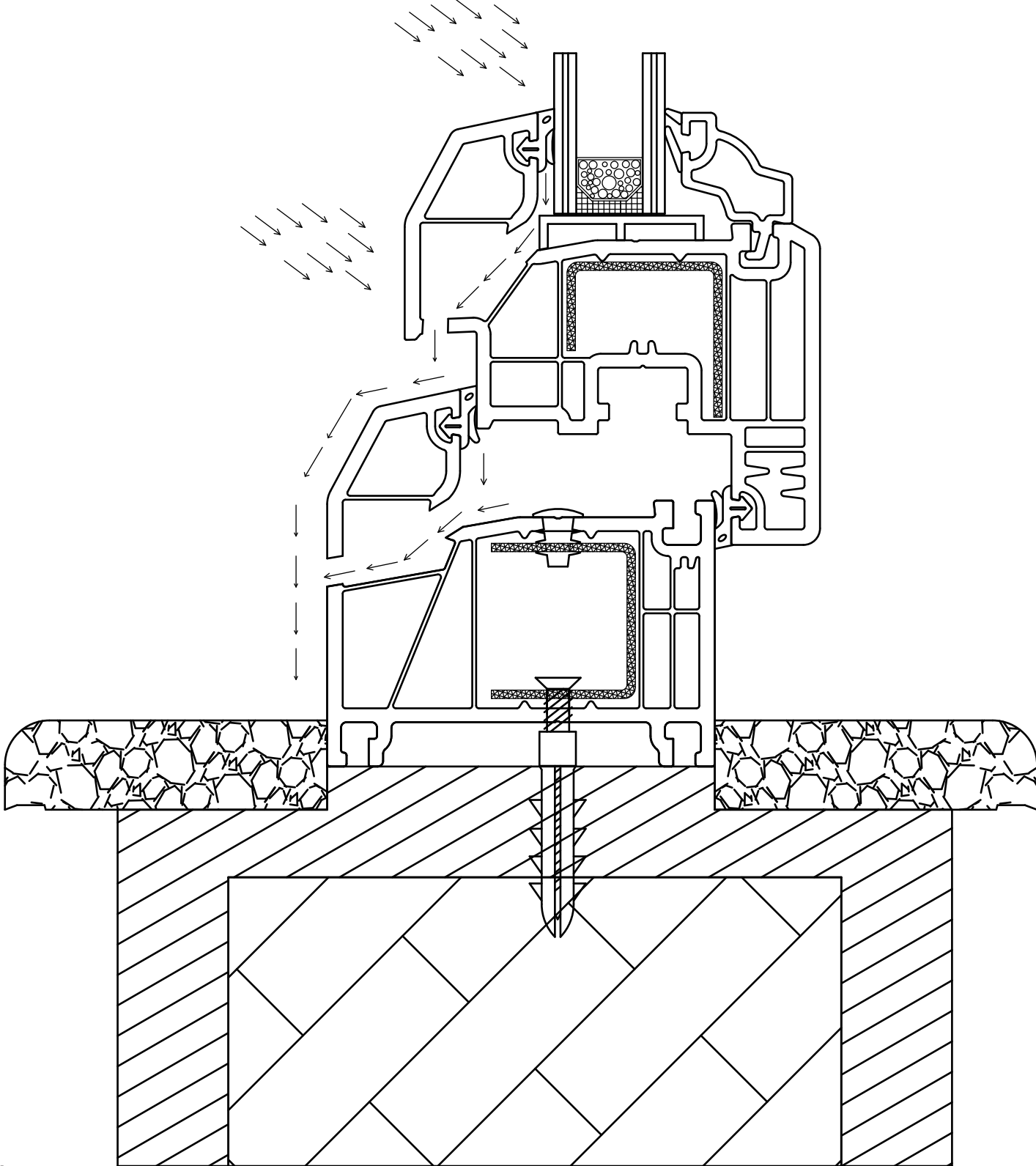
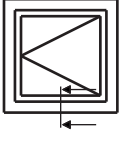

S-705 SU TAHLİYE DETAYI
S-705 WATER DRAINAGE DETAIL

Ölçek 1/1 Scale



www.mywin.com.tr

BESE METAL ve PLASTİK
teknik dökümanlarda değişiklik
yapma hakkını saklı tutar.
reserves the right to make any
modifications on technical
documents.

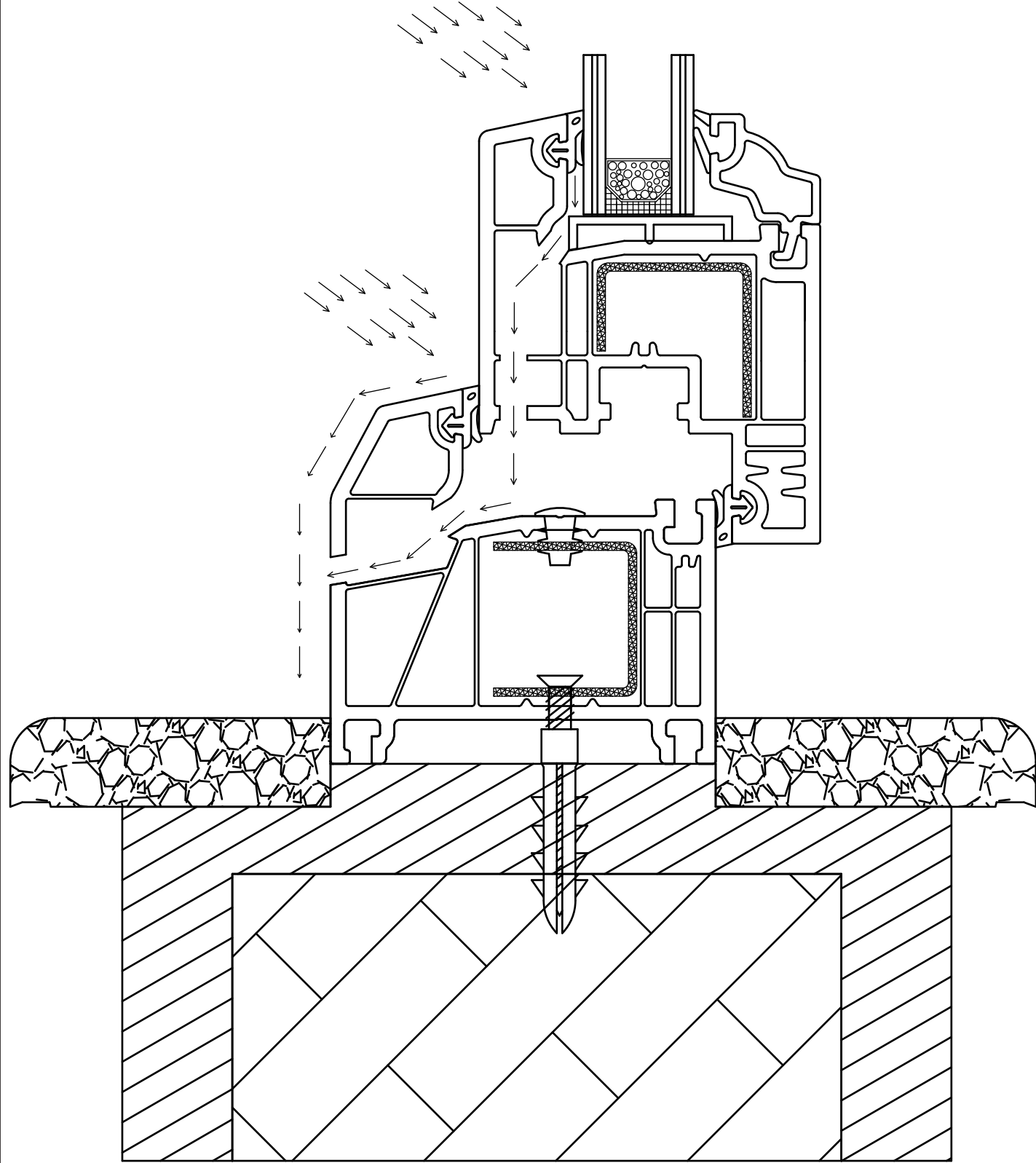
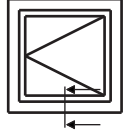

S-705 SU TAHLİYE DETAYI
S-705 WATER DRAINAGE DETAIL

Ölçek 1/1 Scale



www.mywin.com.tr

BESE METAL ve PLASTİK
teknik dökümanlarda değişiklik
yapma hakkını saklı tutar.
reserves the right to make any
modifications on technical
documents.

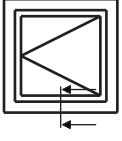

S-705 SU TAHLİYE DETAYI

S-705 WATER DRAINAGE DETAIL

Ölçek 1/1 Scale

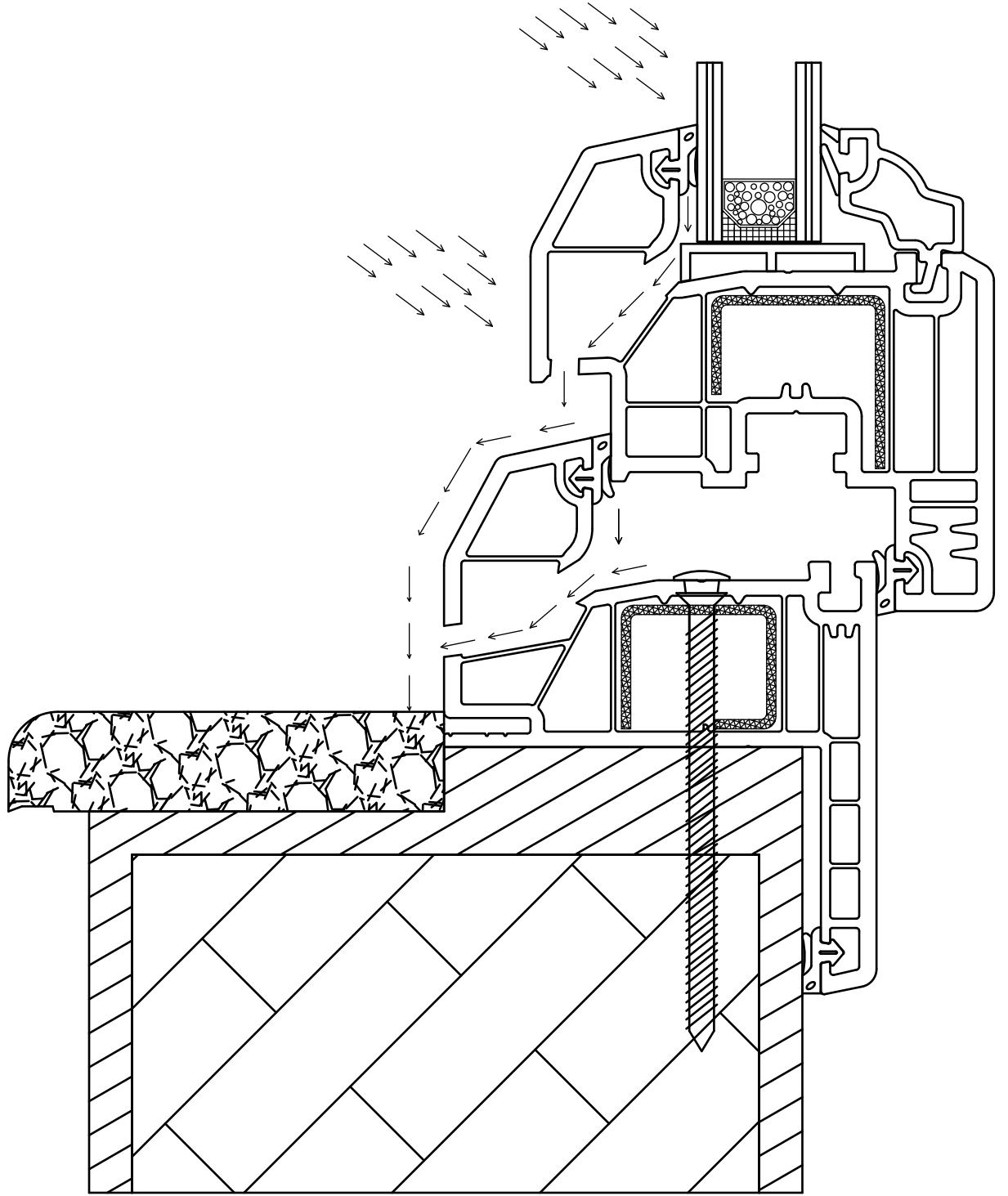

www.mywin.com.tr

BESE METAL ve PLASTİK
teknik dökümanlarda değişiklik
yapma hakkını saklı tutar.
reserves the right to make any
modifications on technical
documents.

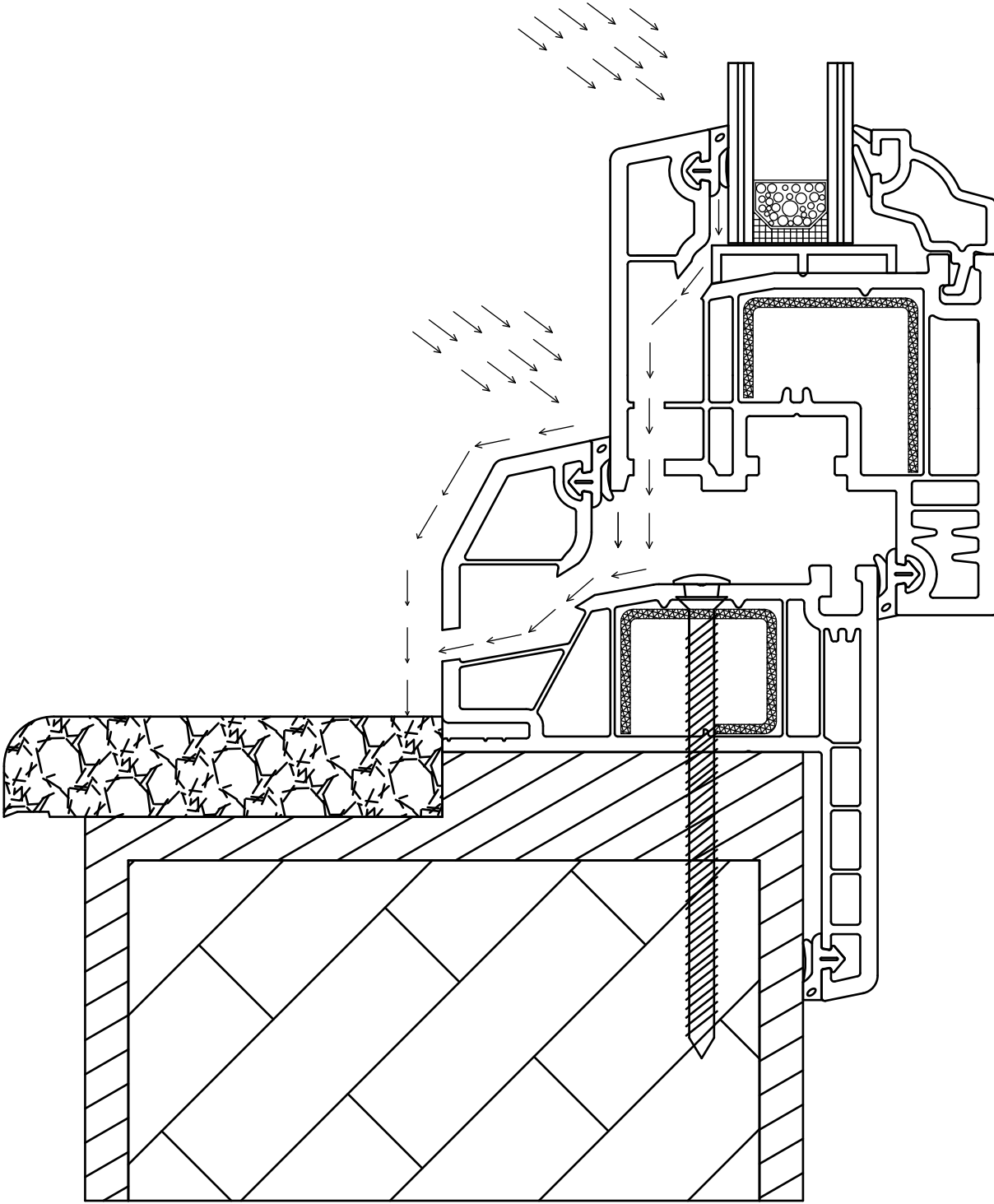
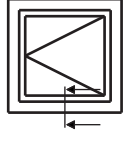

S-705 SU TAHLİYE DETAYI

S-705 WATER DRAINAGE DETAIL

Ölçek 1/1 Scale



www.mywin.com.tr

BESE METAL ve PLASTİK
teknik dökümanlarda değişiklik
yapma hakkını saklı tutar.
reserves the right to make any
modifications on technical
documents.

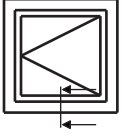

S-705 SU TAHLİYE DETAYI

S-705 WATER DRAINAGE DETAIL

Ölçek 1/1 Scale



www.mywin.com.tr

BESE METAL ve PLASTİK
teknik dökümanlarda değişiklik
yapma hakkını saklı tutar.
reserves the right to make any
modifications on technical
documents.

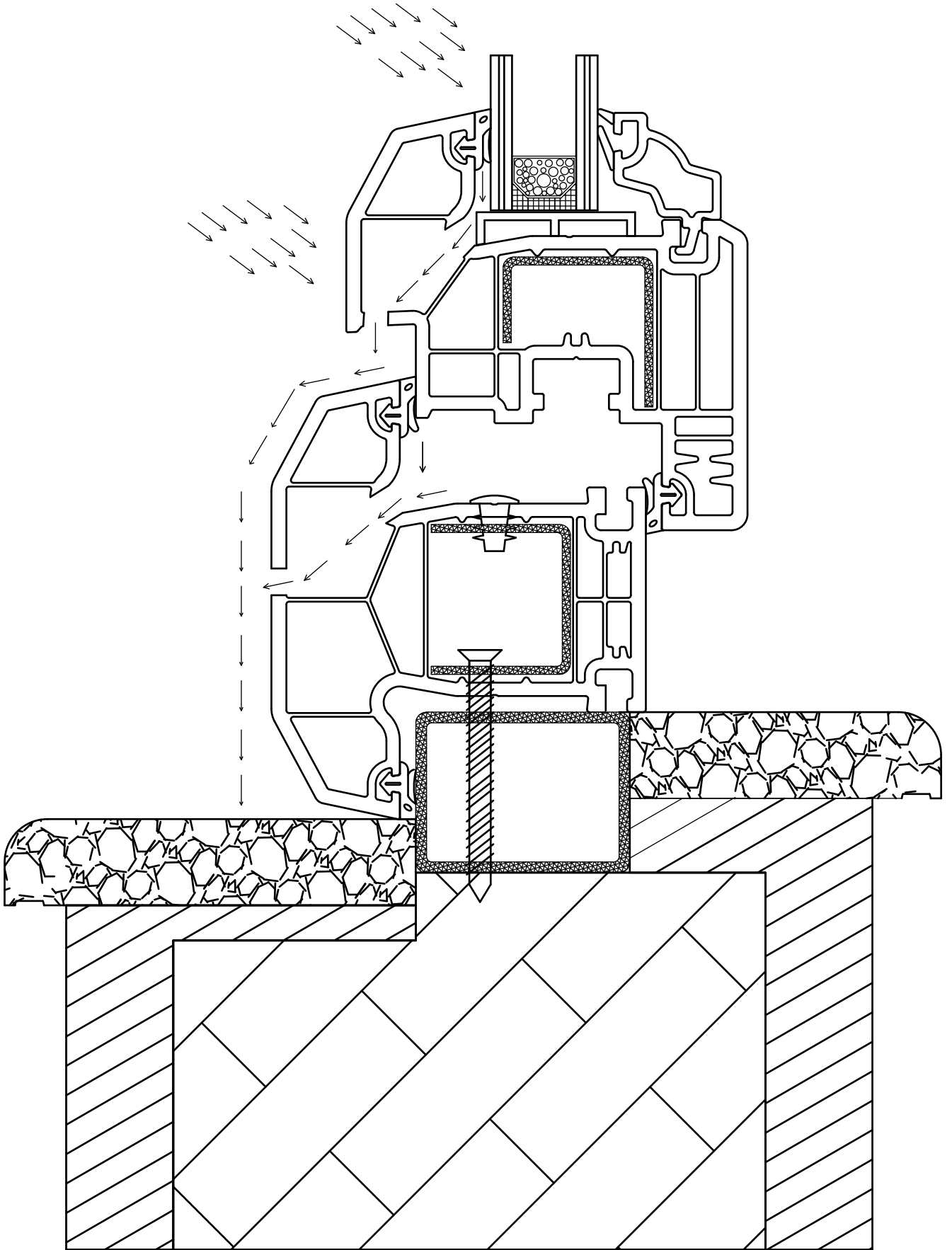

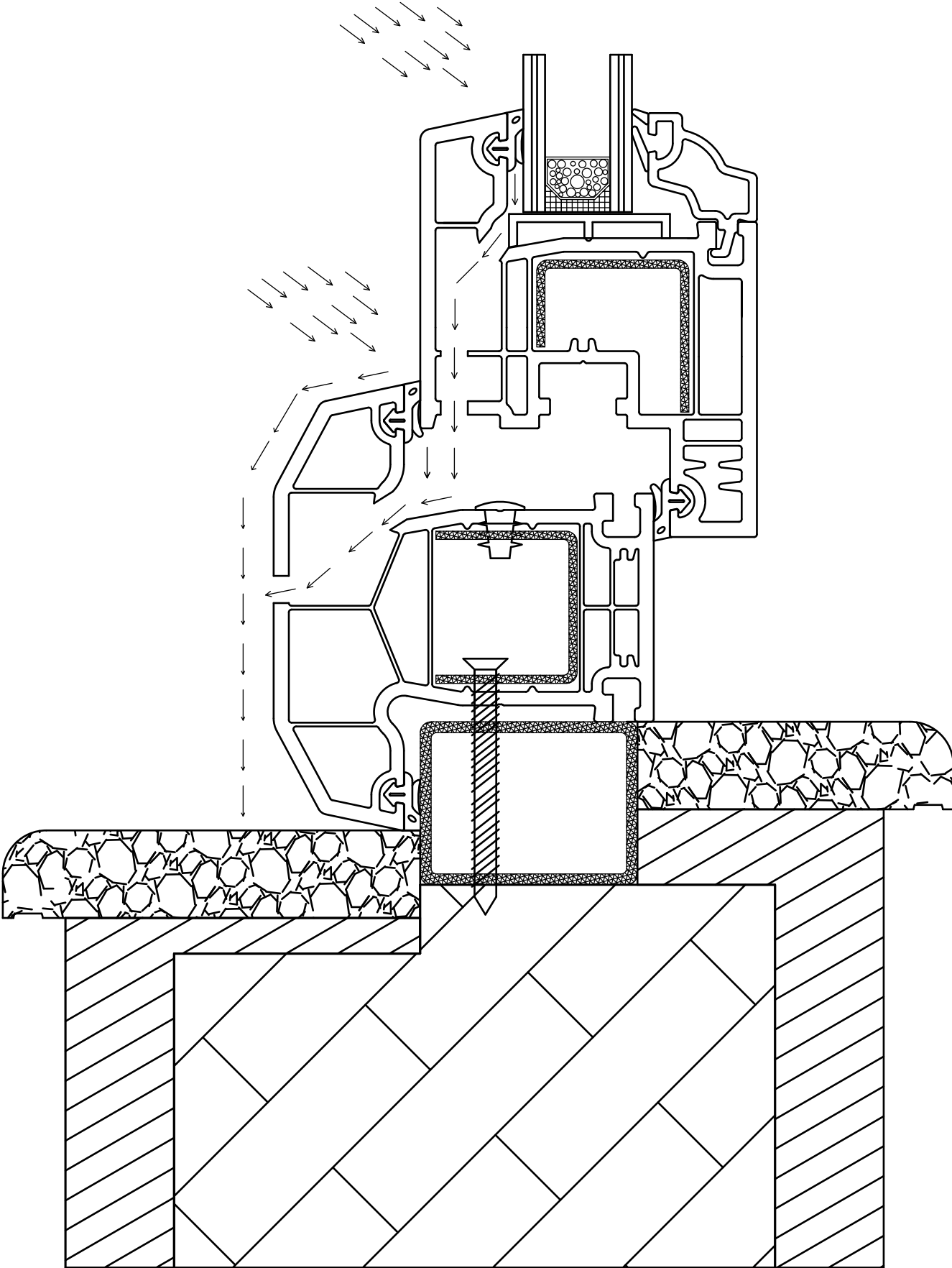
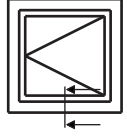

S-705 SU TAHLİYE DETAYI
S-705 WATER DRAINAGE DETAIL

Ölçek 1/1 Scale



www.mywin.com.tr

BESE METAL ve PLASTİK
teknik dökümanlarda değişiklik
yapma hakkını saklı tutar.
reserves the right to make any
modifications on technical
documents.

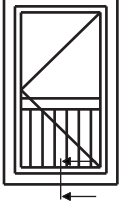

S-705 SU TAHLİYE DETAYI

S-705 WATER DRAINAGE DETAIL

Ölçek 1/1 Scale



PVC Window & Door Systems

www.mywin.com.tr

BESE METAL ve PLASTİK
teknik dokümanlarda değişiklik
yapma hakkını saklı tutar.
reserves the right to make any
modifications on technical
documents.

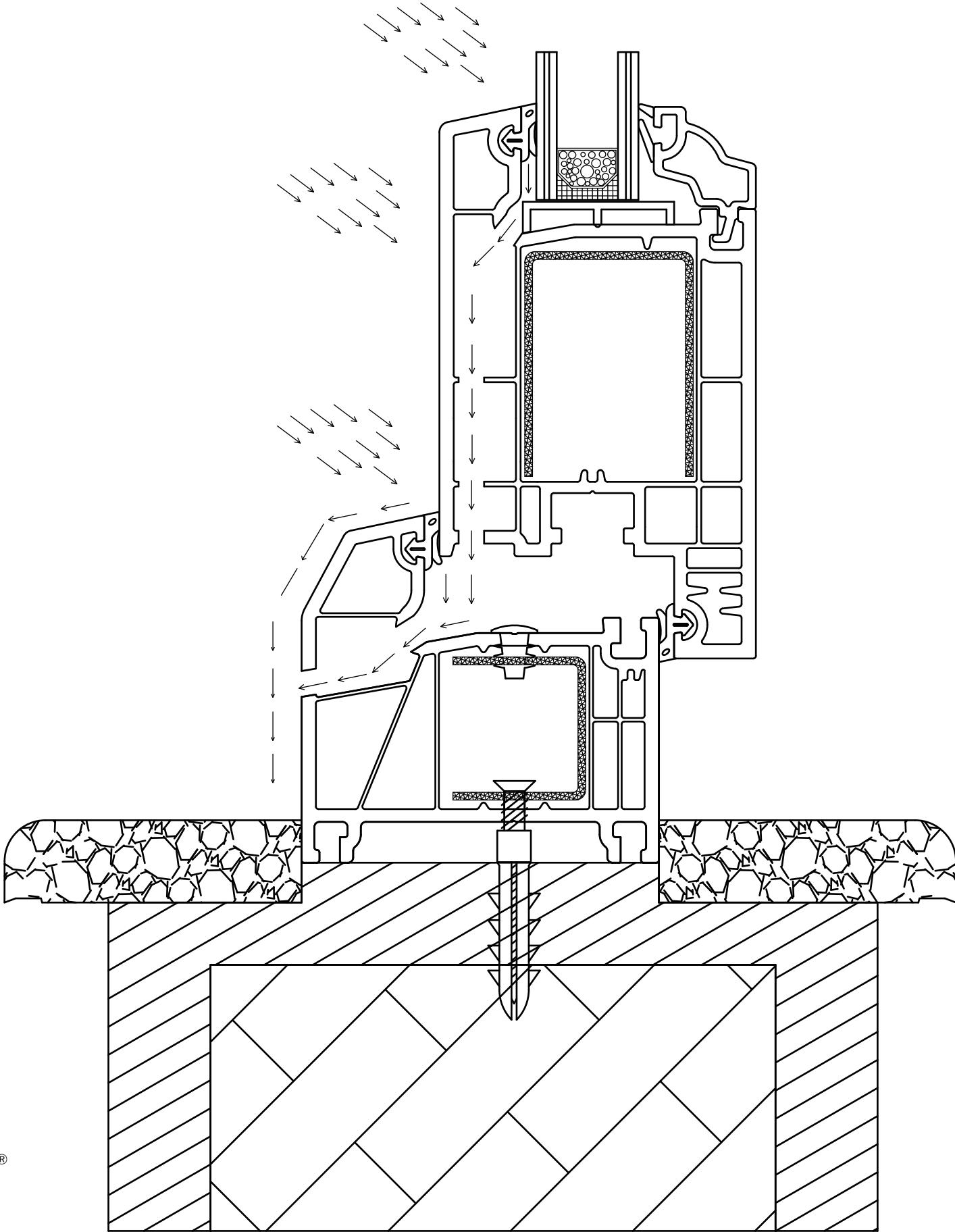

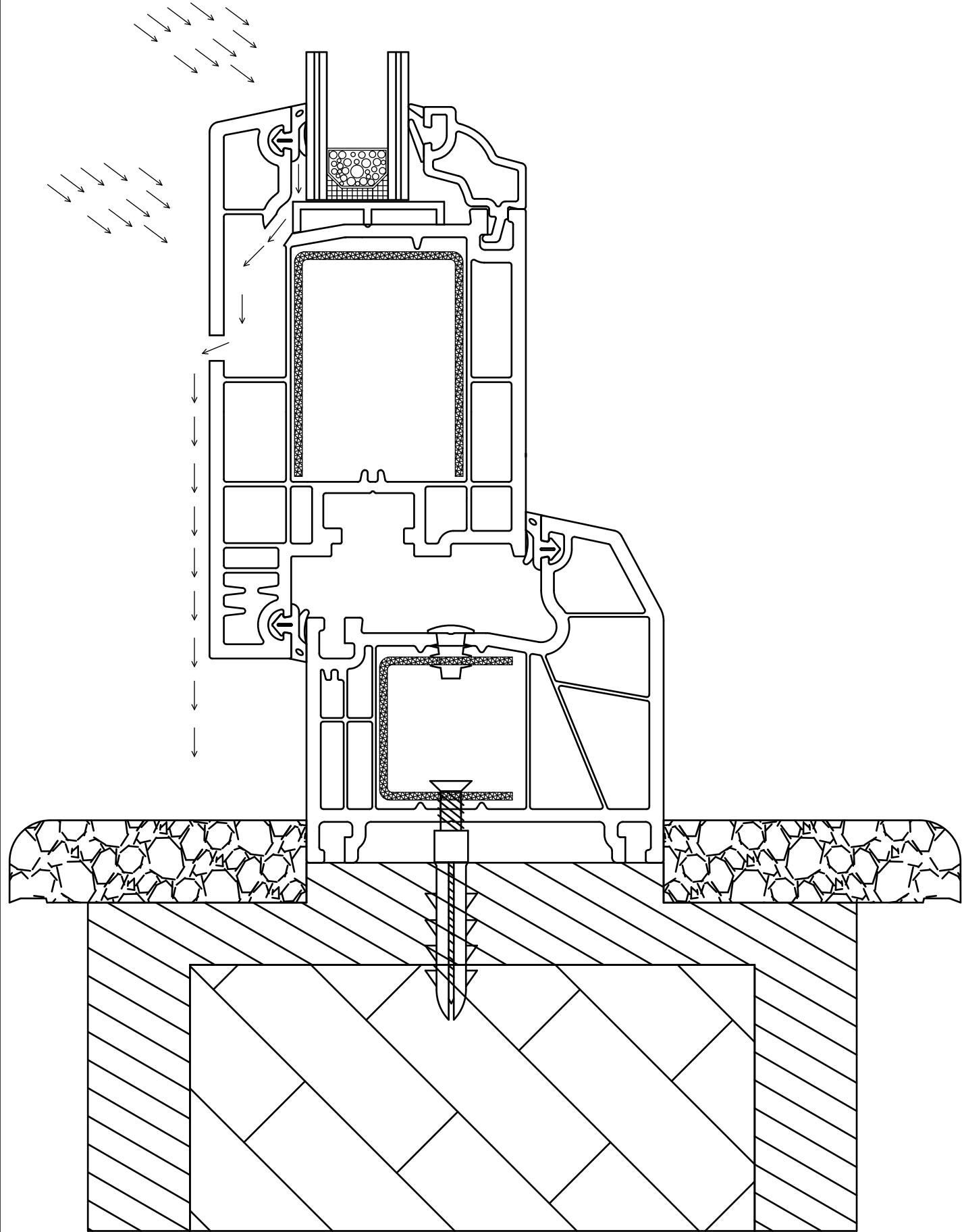
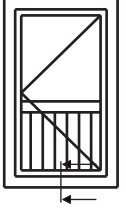

S-705 SU TAHLİYE DETAYI
S-705 WATER DRAINAGE DETAIL

Ölçek 1/1 Scale



www.mywin.com.tr

BESE METAL ve PLASTİK
teknik dökümanlarda değişiklik
yapma hakkını saklı tutar.
reserves the right to make any
modifications on technical
documents.

PVC Window & Door Systems



www.mywin.com.tr



S-863

sürme serisi profilleri
sliding series profiles

S-863 SÜRME KASA PROFİLİ
Ürün Kodu / Product Code: 863.10.00.0
S-863 SLIDING FRAME PROFILE

Ölçek 1/1 Scale

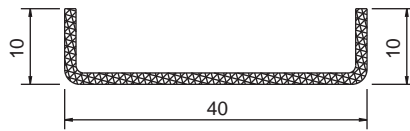
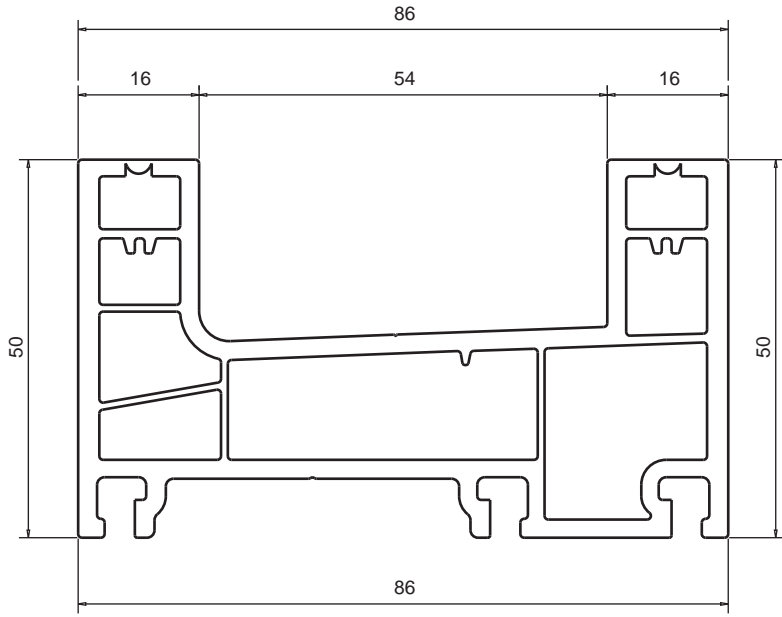

www.mywin.com.tr

BESE METAL ve PLASTİK
teknik dökümanlarda değişiklik
yapma hakkını saklı tutar.
reserves the right to make any
modifications on technical
documents.

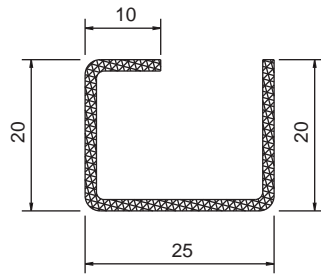
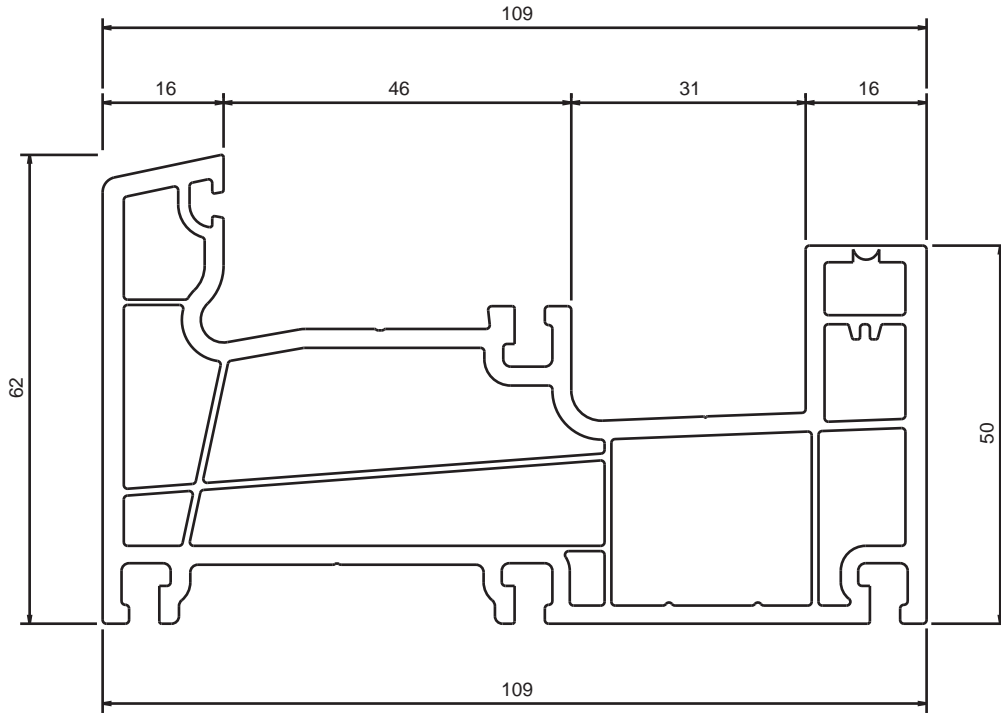

S-863 SÜRME SABİT KASA PROFİLİ
Ürün Kodu / Product Code: 863.11.00.0
S-863 SLIDING FIXED FRAME PROFILE

Ölçek 1/1 Scale



www.mywin.com.tr

BESE METAL ve PLASTİK
teknik dökümanlarda değişiklik
yapma hakkını saklı tutar.
reserves the right to make any
modifications on technical
documents.

S-863 SÜRME KANAT PROFİLİ
Ürün Kodu / Product Code: 863.30.00.0
S-863 SLIDING SASH PROFILE

Ölçek 1/1 Scale



www.mywin.com.tr

BESE METAL ve PLASTİK
teknik dokümanlarda değişiklik
yapma hakkını saklı tutar.
reserves the right to make any
modifications on technical
documents.

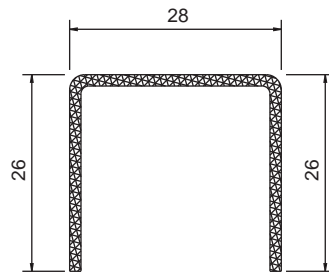
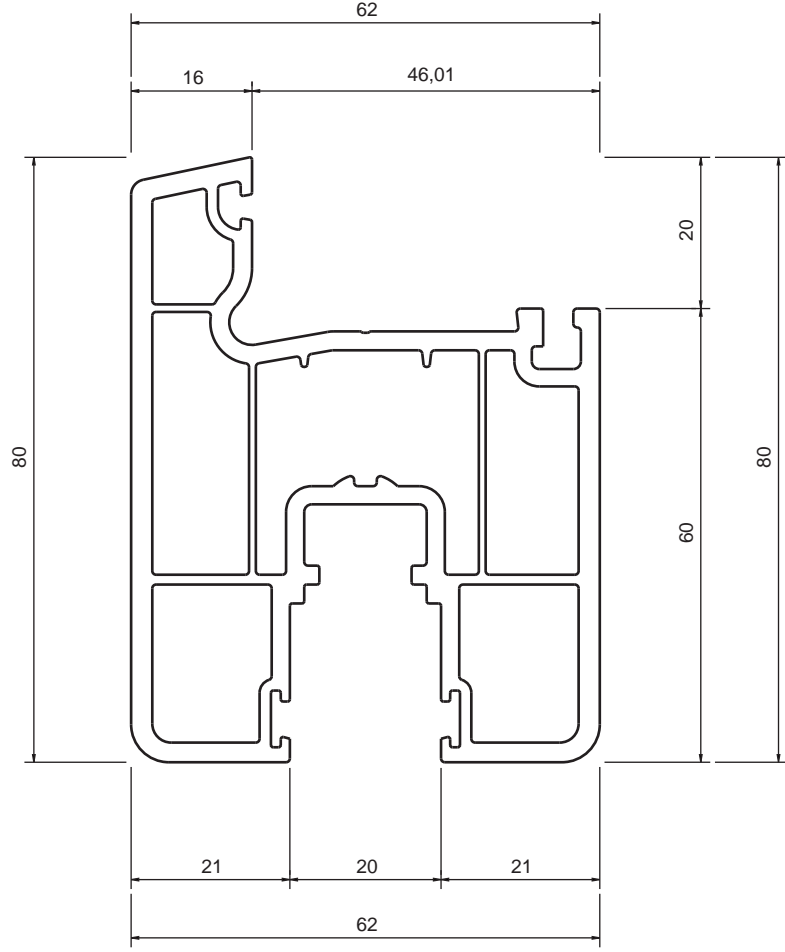

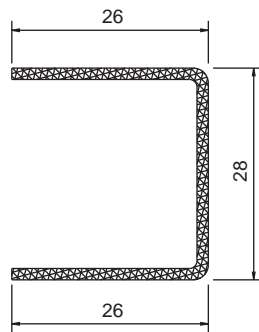
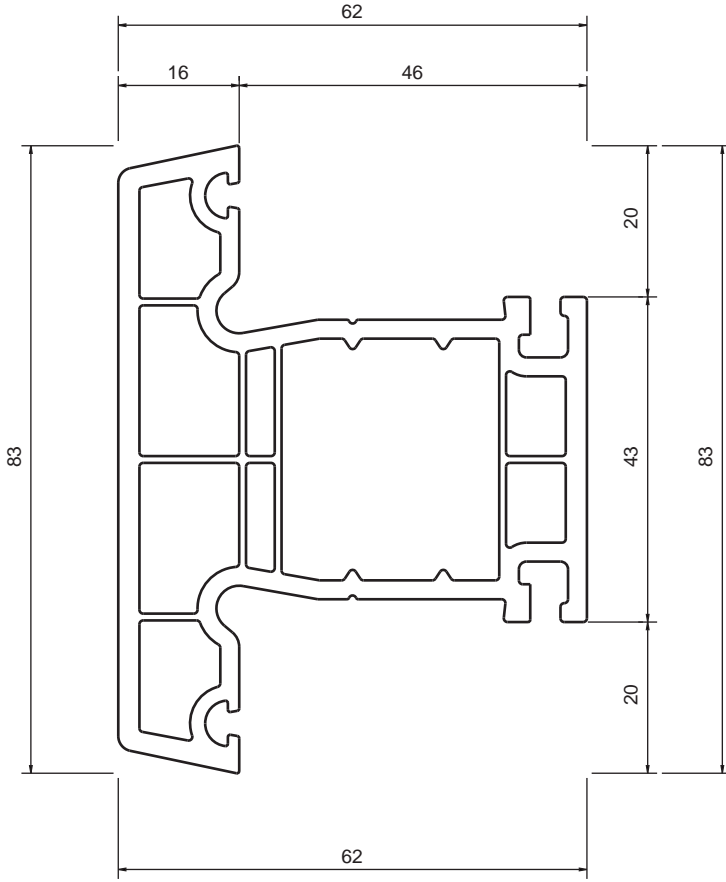

S-624 ORTA KAYIT PROFİLİ
Ürün Kodu / Product Code: 624.21.00.0
S-624 MULLION PROFILE

Ölçek 1/1 Scale



www.mywin.com.tr

BESE METAL ve PLASTİK
teknik dökümanlarda değişiklik
yapma hakkını saklı tutar.
reserves the right to make any
modifications on technical
documents.

S-863 SÜRME İNTERLOK
Ürün Kodu / Product Code: 863.70.00.0
S-863 SLIDING INTERLOCK

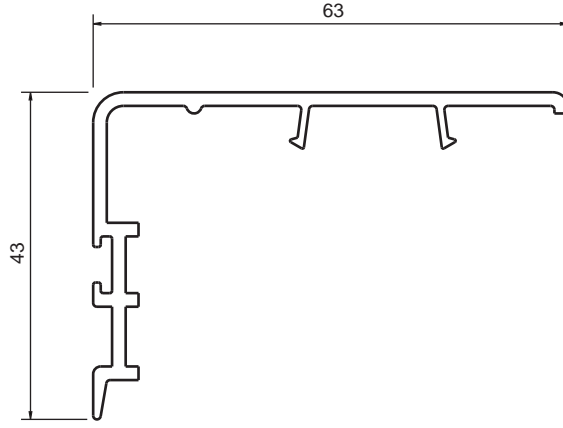

Ölçek 1/1 Scale



www.mywin.com.tr

BESE METAL ve PLASTİK
teknik dökümanlarda değişiklik
yapma hakkını saklı tutar.
reserves the right to make any
modifications on technical
documents.



S-623 SÜRME & S-863 SÜRME SERÝLERÝ ALUMÝNYUM RAY

Ürün Kodu / Product Code: 900.A01.00.0
S-623 SLIDING & S-863 SLIDING SERIES ALUMINIUM RAIL

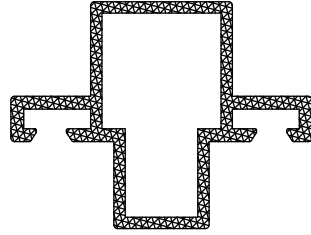

S-623 SÜRME & S-863 SÜRME SERÝLERÝ ALUMÝNYUM KANAT BÝRLEÞTÝRME

Ürün Kodu / Product Code: 900.A02.00.0
S-623 SLIDING & S-863 SLIDING SERIES ALUMINIUM SASH COVER

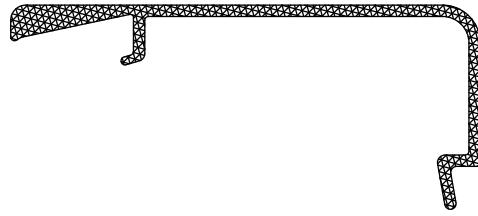

S-863 SÜRME SERÝALUMÝNYUM EÞÝK

Ürün Kodu / Product Code: 900.A04.00.0
S-863 SLIDING SERIE ALUMINIUM THRESHOLD

Ölçek 1/1 Scale



www.mywin.com.tr

BESE METAL ve PLASTİK
teknik dökümanlarda deęişiklik
yapma hakkını saklı tutar.
reserves the right to make any
modifications on technical
documents.

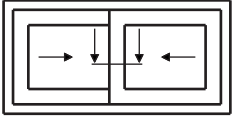

S-863 SÜRME KANAT & SÜRME İNTERLOK & 4mm TEK CAM ÇITASI BİRLEŞİM DETAYI
S-863 SLIDING SASH & SLIDING INTERLOCK & SINGLE GLASS BEAD 4mm APPLICATION DETAIL

Ölçek 1/1 Scale

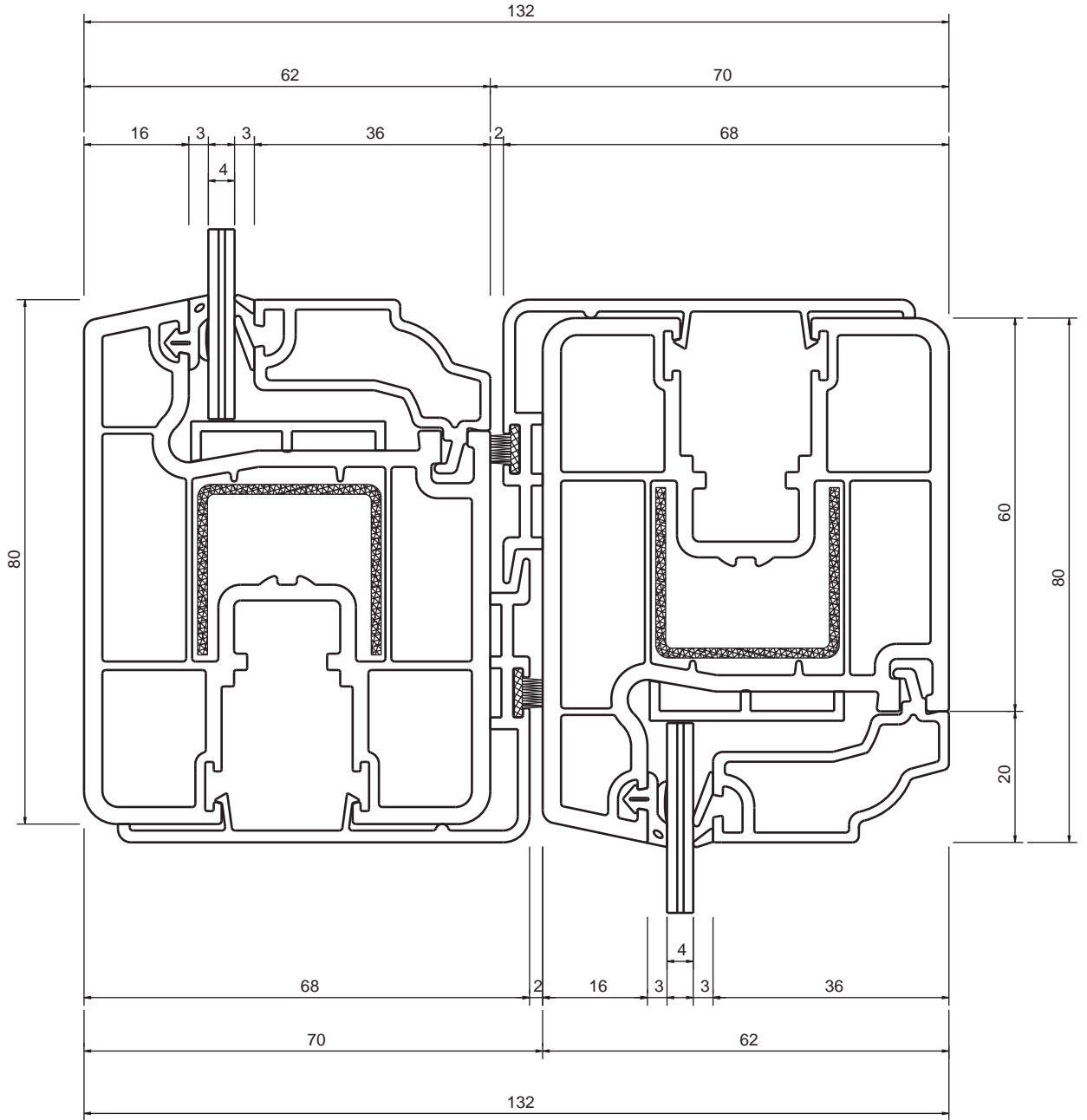

www.mywin.com.tr

BESE METAL ve PLASTİK teknik dökümanlarda değişiklik yapma hakkını saklı tutar.
reserves the right to make any modifications on technical documents.

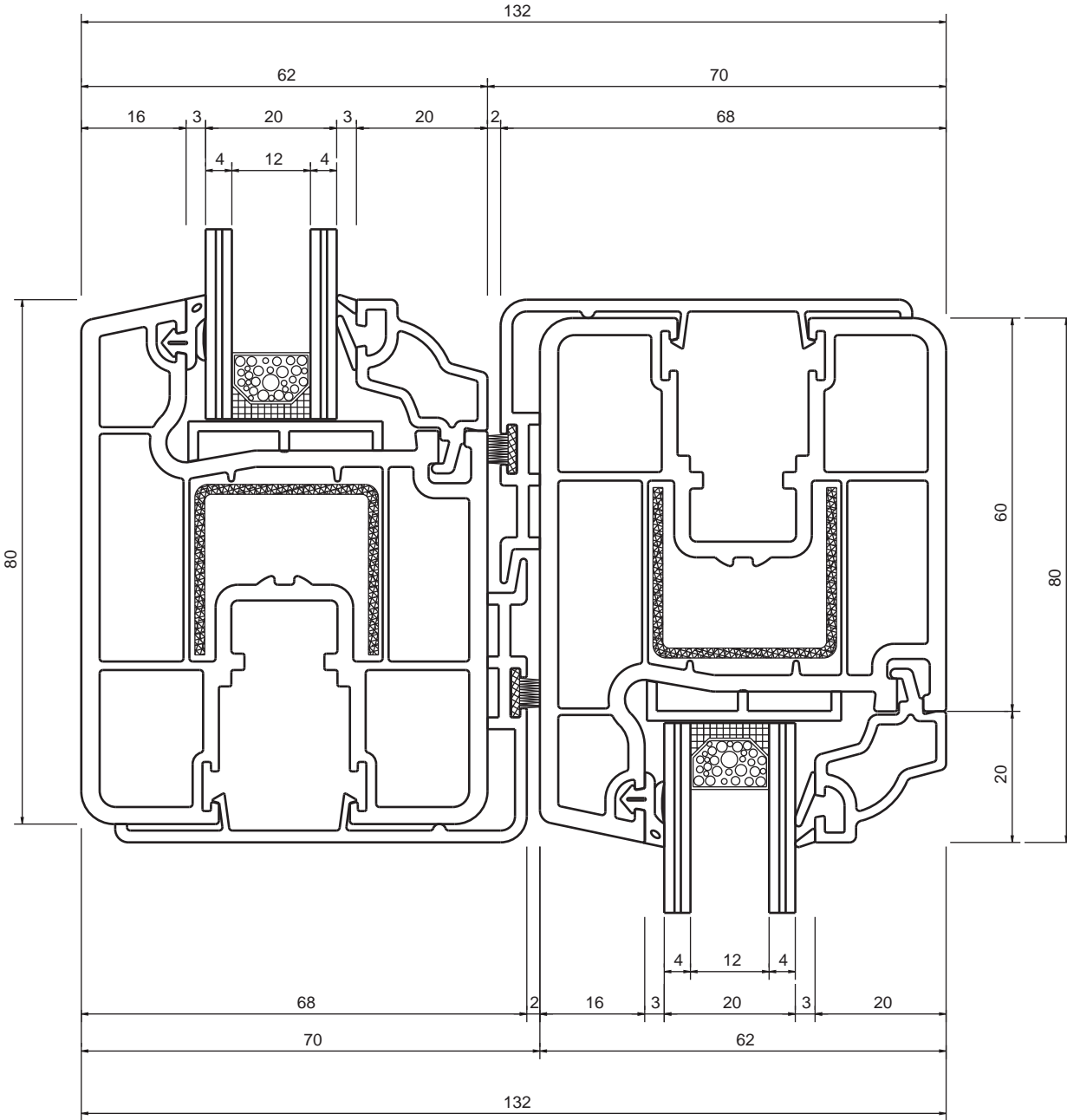
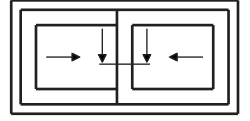

**S-863 SÜRME KANAT & SÜRME İNTERLOK &
20mm ISICAM ÇITASI BİRLEŞİM DETAYI**
S-863 SLIDING SASH & SLIDING INTERLOCK &
DOUBLE GLASS BEAD 20mm APPLICATION DETAIL

Ölçek 1/1 Scale



www.mywin.com.tr

BESE METAL ve PLASTİK
teknik dökümanlarda değişiklik
yapma hakkını saklı tutar.
reserves the right to make any
modifications on technical
documents.

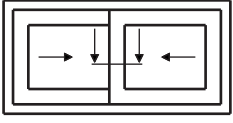

**S-863 SÜRME KANAT & SÜRME İNTERLOK &
24mm İSICAM ÇİTASI BİRLEPİM DETAYI**
S-863 SLIDING SASH & SLIDING INTERLOCK &
DOUBLE GLASS BEAD 24mm APPLICATION DETAIL

Ölçek 1/1 Scale

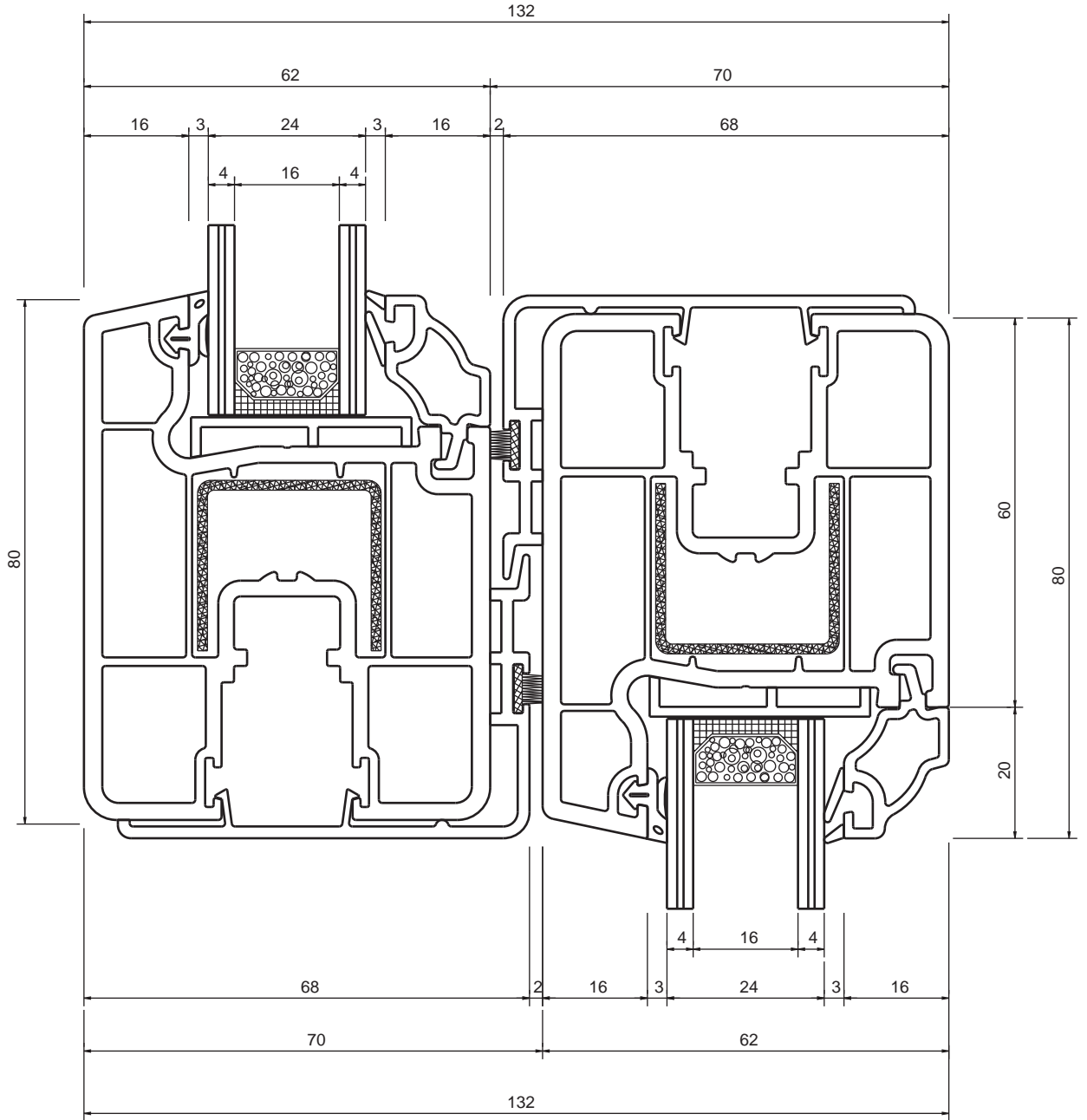

www.mywin.com.tr

BESE METAL ve PLASTİK
teknik dökümanlarda değişiklik
yapma hakkını saklı tutar.
reserves the right to make any
modifications on technical
documents.

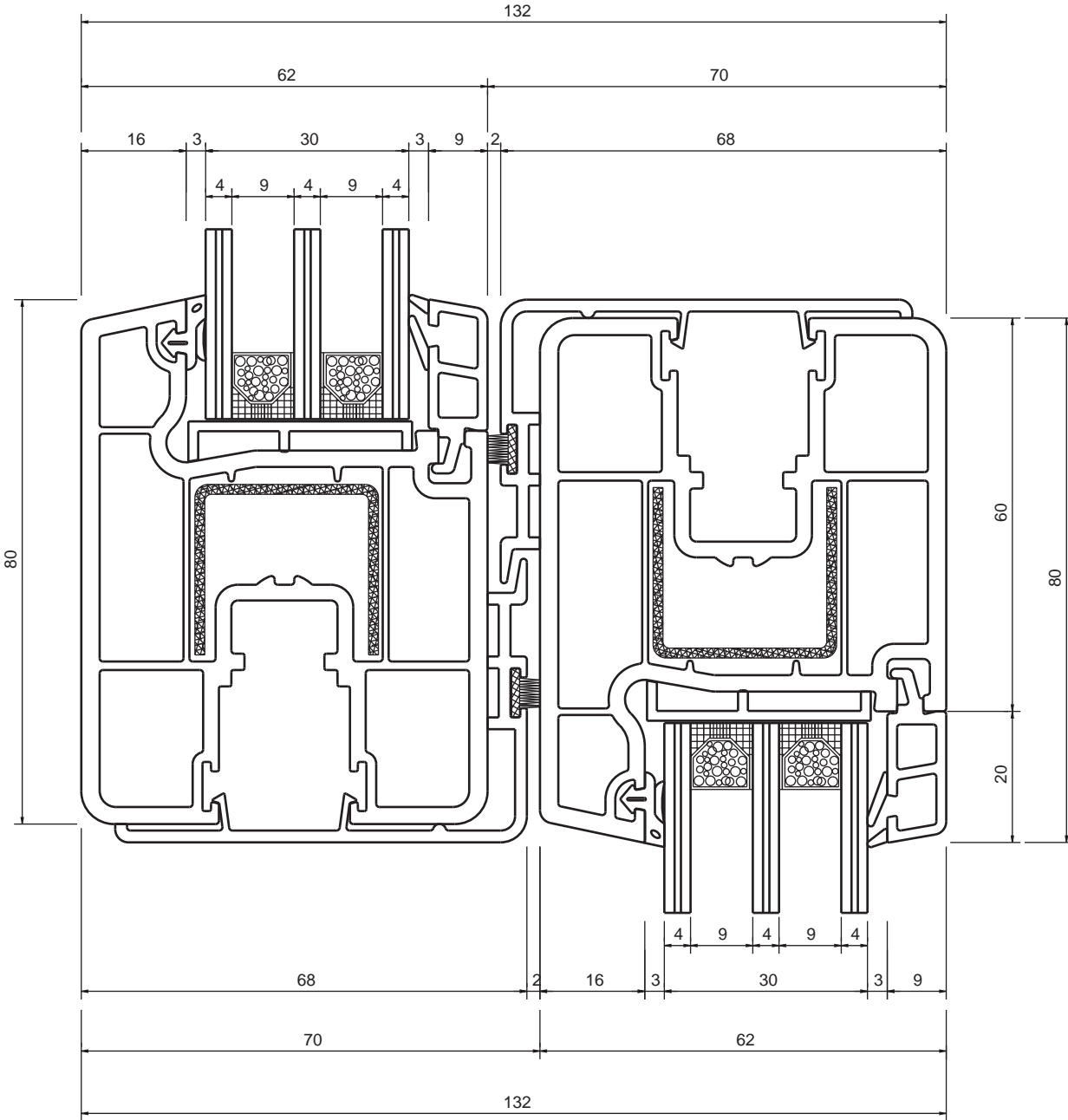
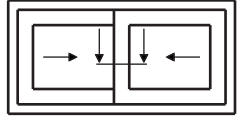

**S-863 SÜRME KANAT & SÜRME İNTERLOK &
30mm ÜÇLÜ CAM ÇITASI BİRLEPİM DETAYI**
S-863 SLIDING SASH & SLIDING INTERLOCK &
TRIPLE GLASS BEAD 30mm APPLICATION DETAIL

Ölçek 1/1 Scale



www.mywin.com.tr

BESE METAL ve PLASTİK
teknik dökümanlarda değışiklik
yapma hakkını saklı tutar.
reserves the right to make any
modifications on technical
documents.

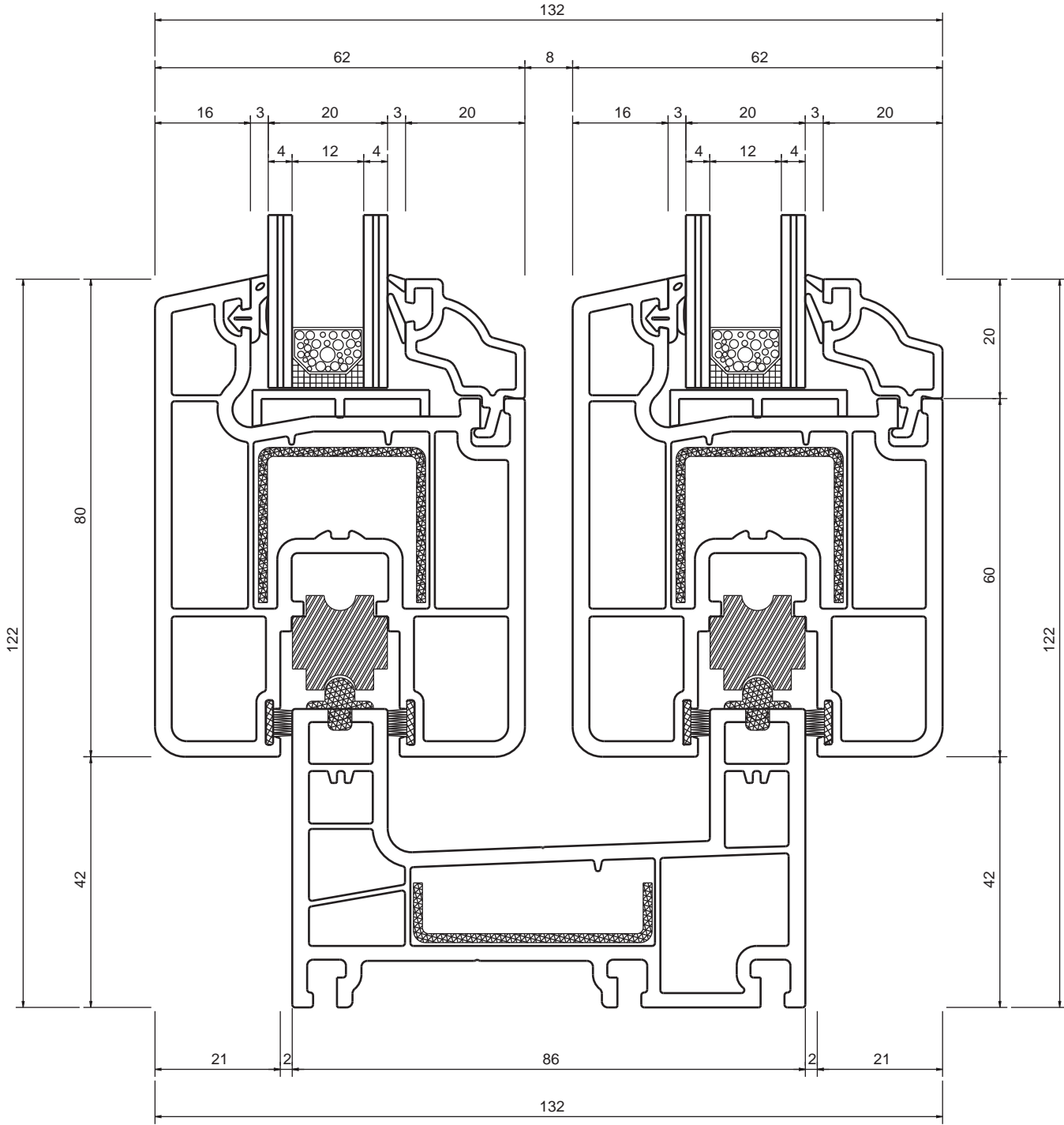
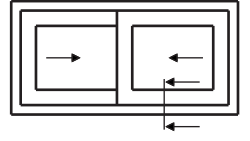

**S-863 SÜRME KASA & S-863 SÜRME KANAT &
20mm ISICAM ÇITASI BİRLEŞİM DETAYI**
S-863 SLIDING FRAME & S-863 SLIDING SASH &
DOUBLE GLASS BEAD 20mm APPLICATION DETAIL

Ölçek 1/1 Scale



www.mywin.com.tr

BESE METAL ve PLASTİK
teknik dökümanlarda değişiklik
yapma hakkını saklı tutar.
reserves the right to make any
modifications on technical
documents.

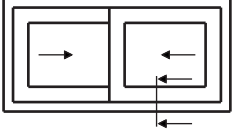

**S-863 SÜRME KASA & S-863 SÜRME KANAT &
24mm ISICAM ÇITASI BİRLEŞİM DETAYI**
S-863 SLIDING FRAME & S-863 SLIDING SASH &
DOUBLE GLASS BEAD 24mm APPLICATION DETAIL

Ölçek 1/1 Scale



www.mywin.com.tr

BESE METAL ve PLASTİK
teknik dokümanlarda değişiklik
yapma hakkını saklı tutar.
reserves the right to make any
modifications on technical
documents.

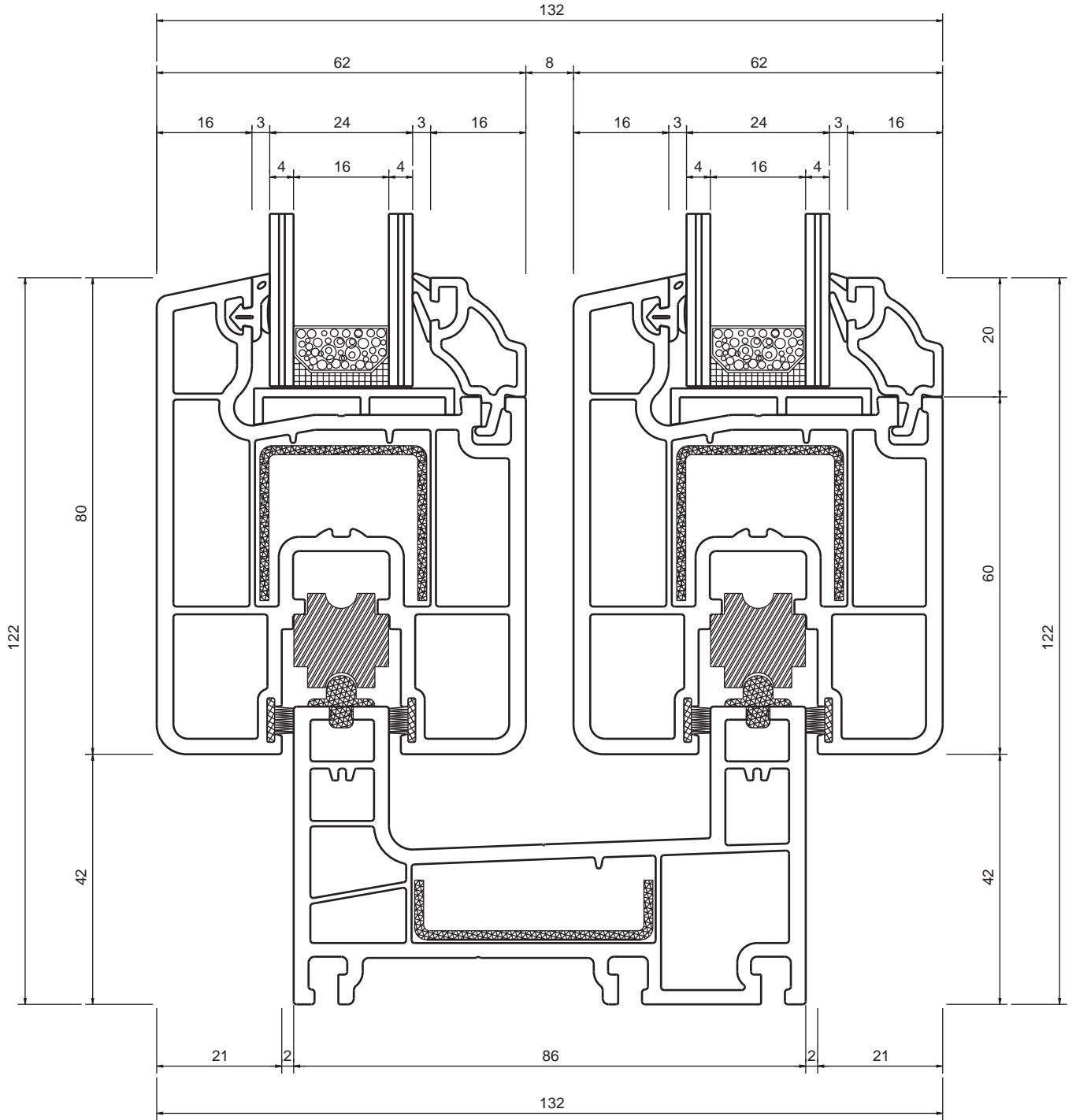

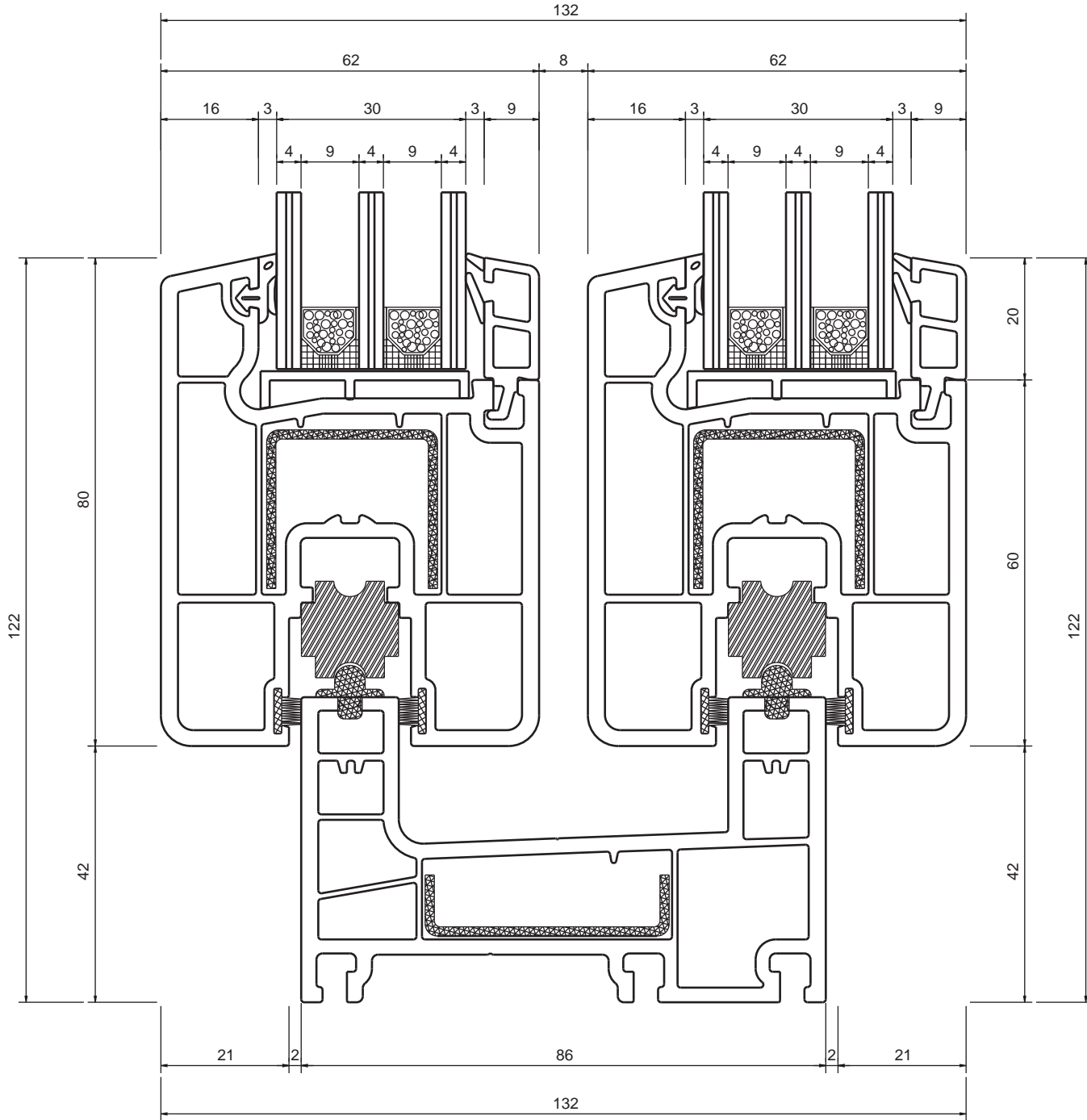
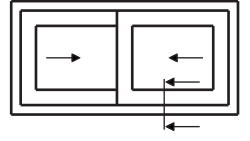

**S-863 SÜRME KASA & S-863 SÜRME KANAT &
30mm ÜÇLÜ CAM ÇITASI BİRLEŞİM DETAYI**
S-863 SLIDING FRAME & S-863 SLIDING SASH &
TRIPLE GLASS BEAD 30mm APPLICATION DETAIL

Ölçek 1/1 Scale



www.mywin.com.tr

BESE METAL ve PLASTİK
teknik dökümanlarda değişiklik
yapma hakkını saklı tutar.
reserves the right to make any
modifications on technical
documents.

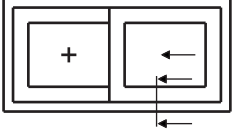

**S-863 SÜRME SABİT KASA & S-863 SÜRME KANAT &
4mm TEK CAM ÇITASI BİRLEŞİM DETAYI**
S-863 SLIDING FIXED FRAME & S-863 SLIDING SASH &
SINGLE GLASS BEAD 4mm APPLICATION DETAIL

Ölçek 1/1 Scale



PVC Window & Door Systems

www.mywin.com.tr

BESE METAL ve PLASTİK
teknik dökümanlarda değişiklik
yapma hakkını saklı tutar.
reserves the right to make any
modifications on technical
documents.

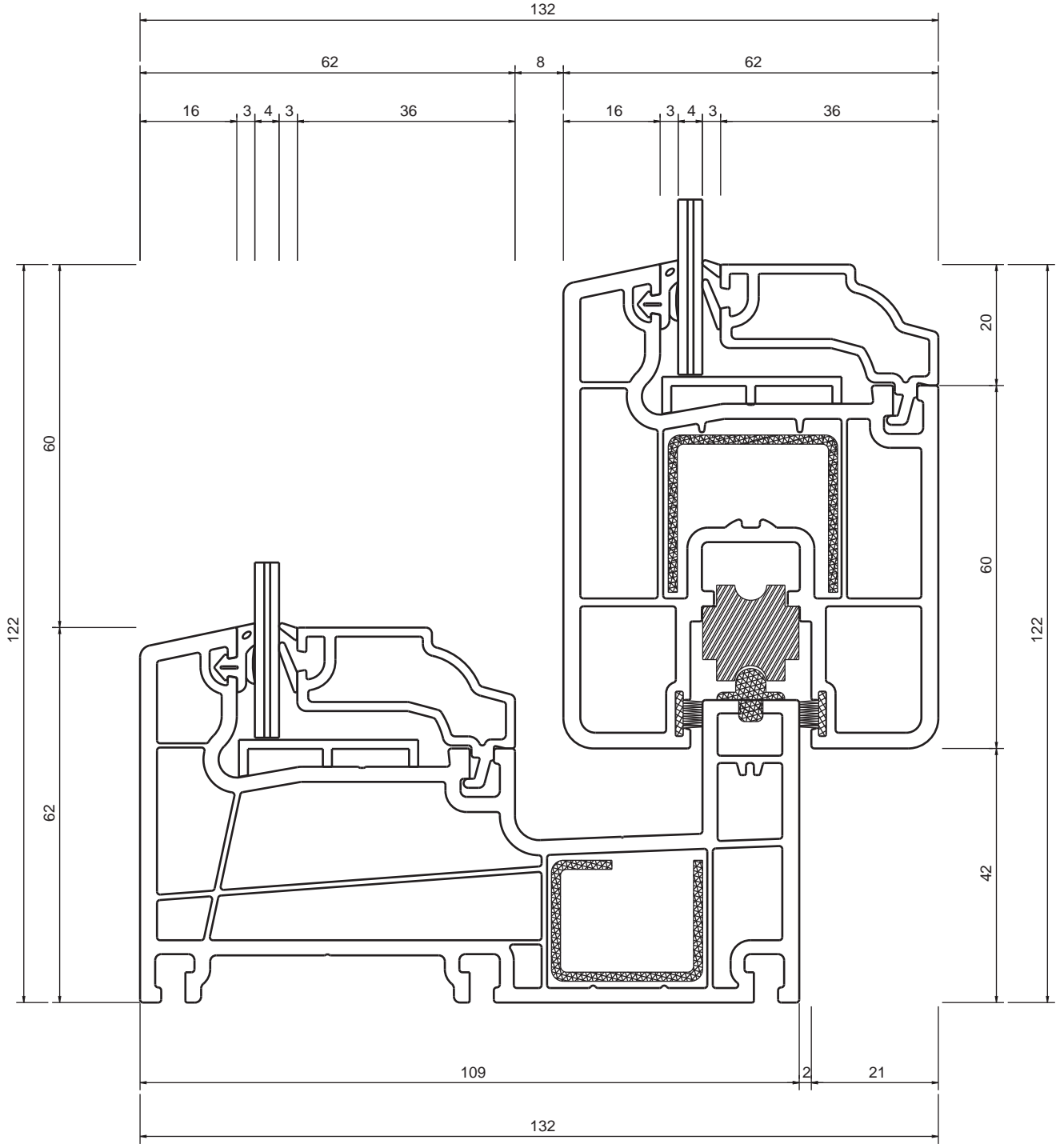

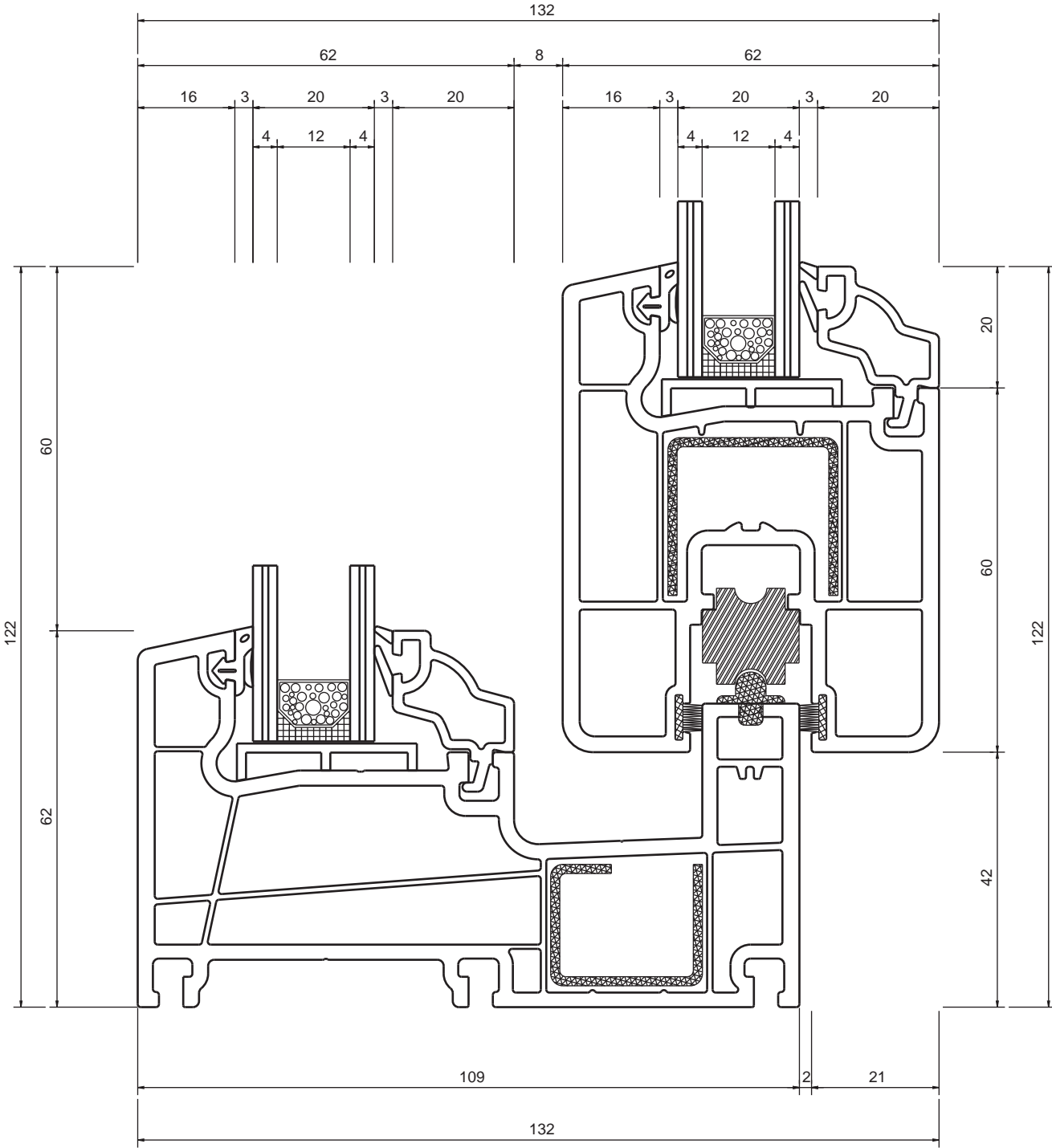
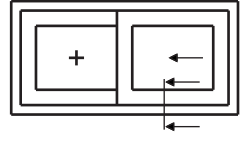

**S-863 SÜRME SABİT KASA & S-863 SÜRME KANAT &
20mm ISICAM ÇITASI BİRLEŞİM DETAYI**
S-863 SLIDING FIXED FRAME & S-863 SLIDING SASH &
DOUBLE GLASS BEAD 20mm APPLICATION DETAIL

Ölçek 1/1 Scale



www.mywin.com.tr

BESE METAL ve PLASTİK
teknik dökümanlarda değişiklik
yapma hakkını saklı tutar.
reserves the right to make any
modifications on technical
documents.

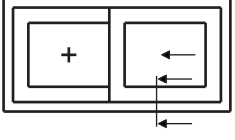

**S-863 SÜRME SABİT KASA & S-863 SÜRME KANAT &
24mm ISICAM ÇITASI BİRLEŞİM DETAYI**
S-863 SLIDING FIXED FRAME & S-863 SLIDING SASH &
DOUBLE GLASS BEAD 24mm APPLICATION DETAIL

Ölçek 1/1 Scale



www.mywin.com.tr

BESE METAL ve PLASTİK
teknik dökümanlarda değişiklik
yapma hakkını saklı tutar.
reserves the right to make any
modifications on technical
documents.

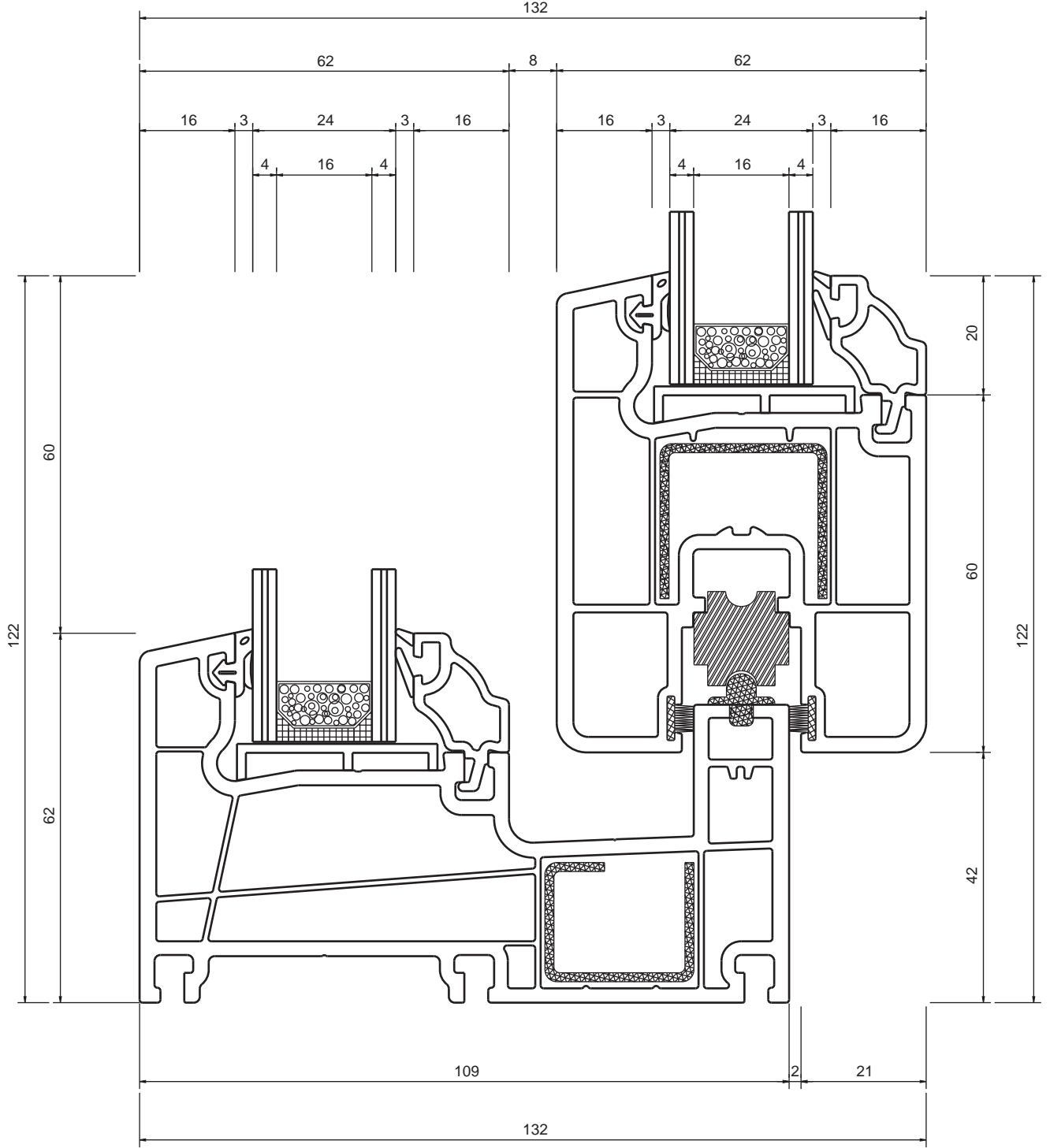

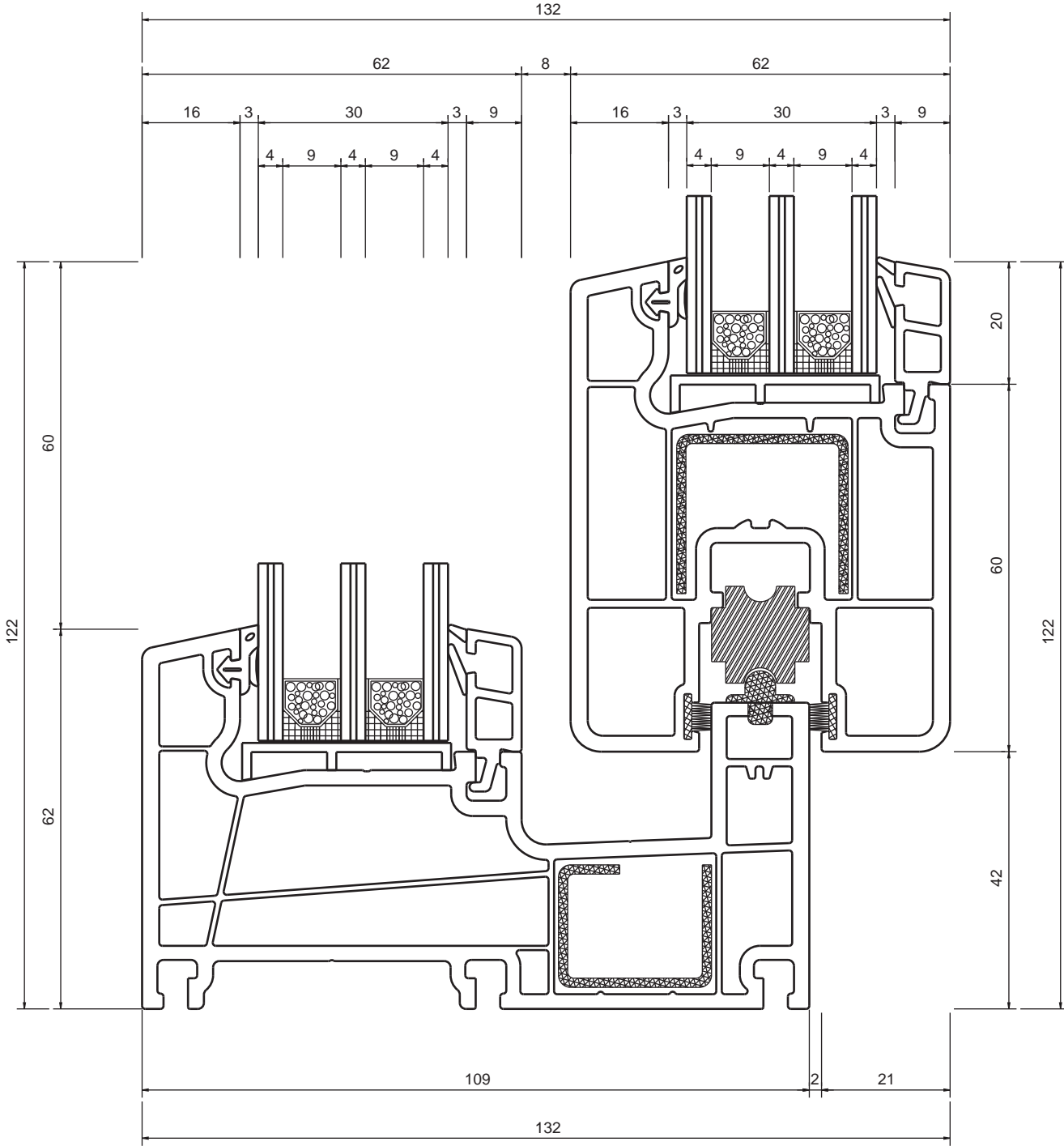
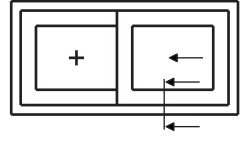

**S-863 SÜRME SABİT KASA & S-863 SÜRME KANAT &
30mm ÜÇLÜ CAM ÇITASI BİRLEŞİM DETAYI**
S-863 SLIDING FIXED FRAME & S-863 SLIDING SASH &
TRIPLE GLASS BEAD 30mm APPLICATION DETAIL

Ölçek 1/1 Scale



www.mywin.com.tr

BESE METAL ve PLASTİK
teknik dökümanlarda değişiklik
yapma hakkını saklı tutar.
reserves the right to make any
modifications on technical
documents.

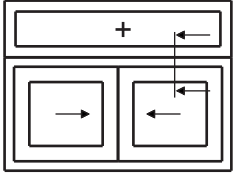

**S-863 SÜRME KASA & BAĐ PROFİLÝ &
S-624 KASA BÝRLEŐM DETAYI**
S-863 SLIDING FRAME & COUPLING &
S-624 FRAME APPLICATION DETAIL

Ölçek 1/1 Scale



www.mywin.com.tr

BESE METAL ve PLASTİK
teknik dökümanlarda deęişiklik
yapma hakkını saklı tutar.
reserves the right to make any
modifications on technical
documents.

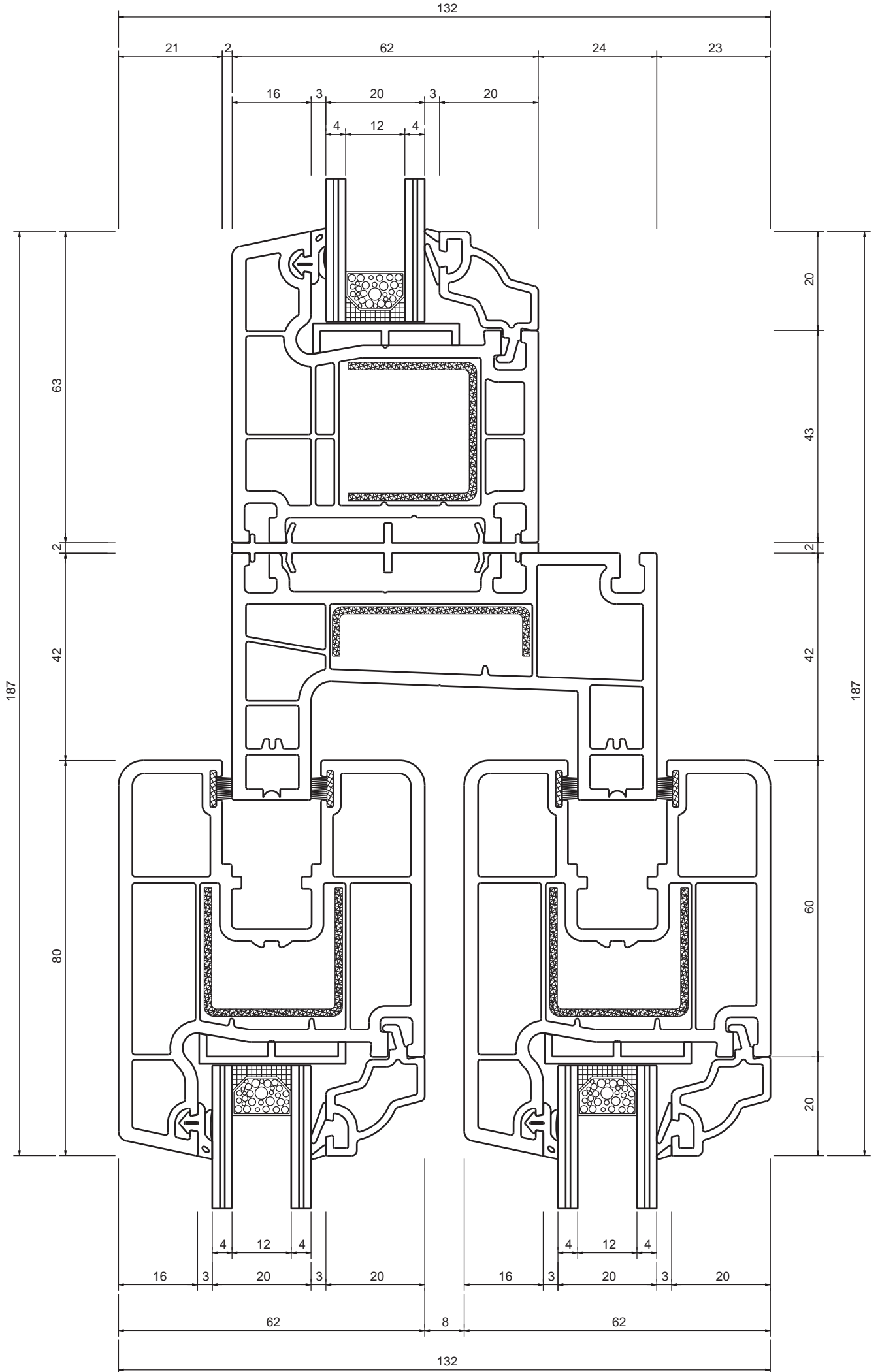

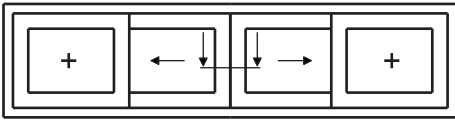

S-863 SÜRME KANAT & ALUMİNYUM KANAT BİRLEŞTİRME &
S-863 SÜRME KANAT BİRLEŞİM DETAYI
S-863 SLIDING SASH & ALUMINIUM SASH CONNECTER &
S-863 SLIDING SASH APPLICATION DETAIL

Ölçek 1/1 Scale



www.mywin.com.tr

BESE METAL ve PLASTİK
teknik dokümanlarda değişiklik
yapma hakkını saklı tutar.
reserves the right to make any
modifications on technical
documents.

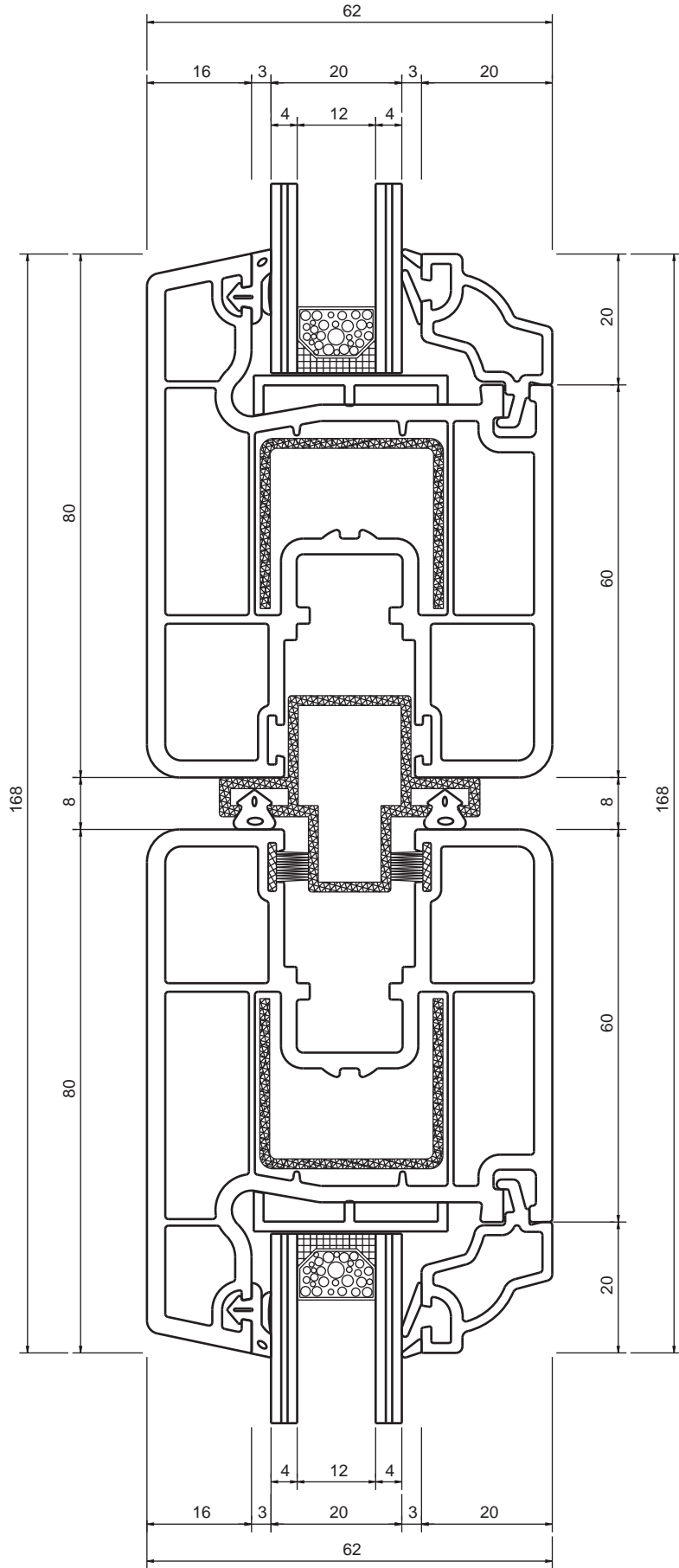

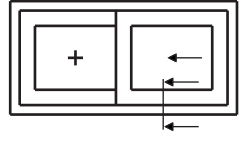
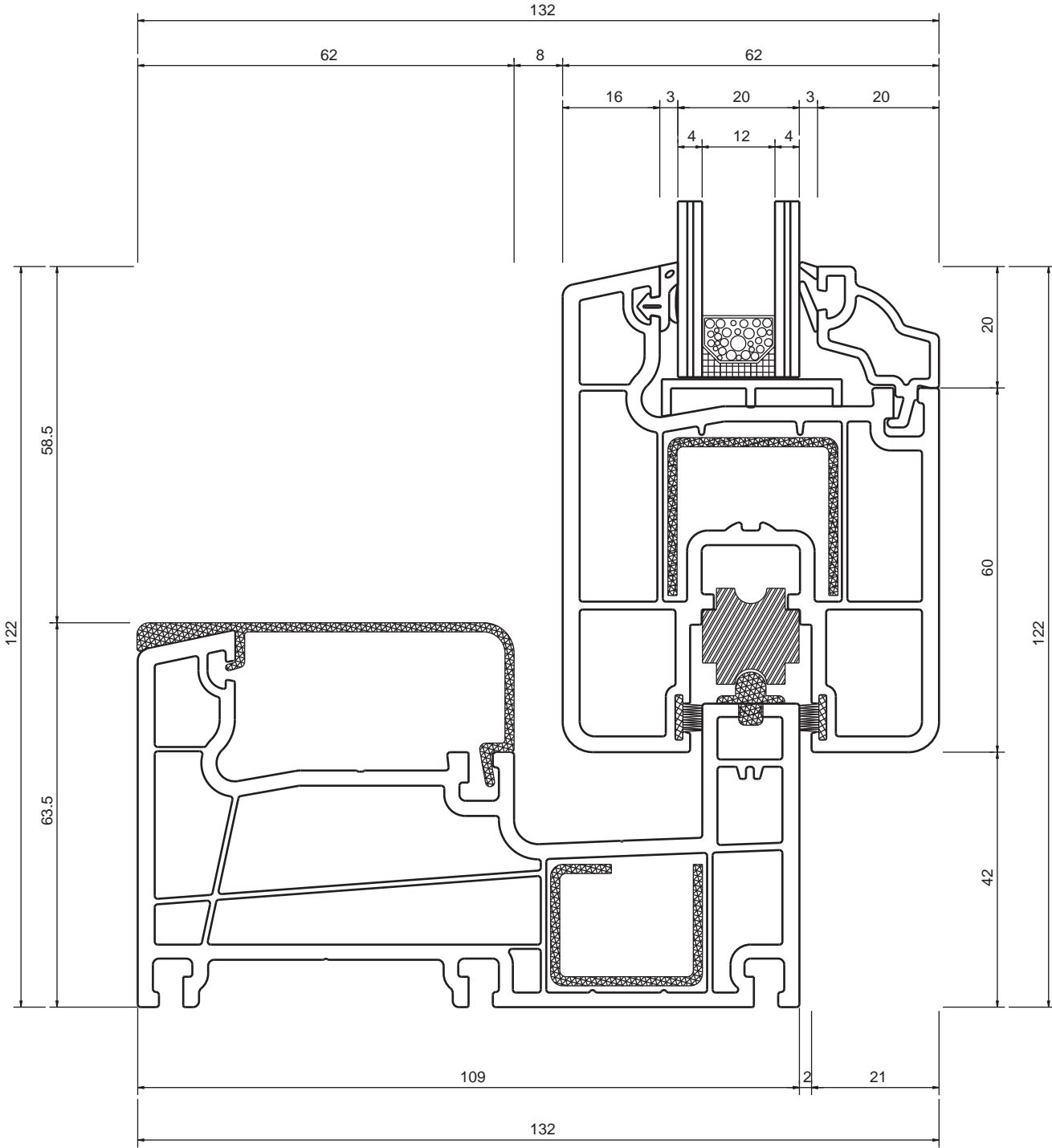

**S-863 SÜRME SABİT KASA & S-863 SÜRME KANAT &
ALUMİNYUM EPK BİRLEŞİM DETAYI**
S-863 SLIDING FIXED FRAME & S-863 SLIDING SASH &
ALUMINIUM THRESHOLD APPLICATION DETAIL

Ölçek 1/1 Scale



www.mywin.com.tr

BESE METAL ve PLASTİK
teknik dökümanlarda değişiklik
yapma hakkını saklı tutar.
reserves the right to make any
modifications on technical
documents.

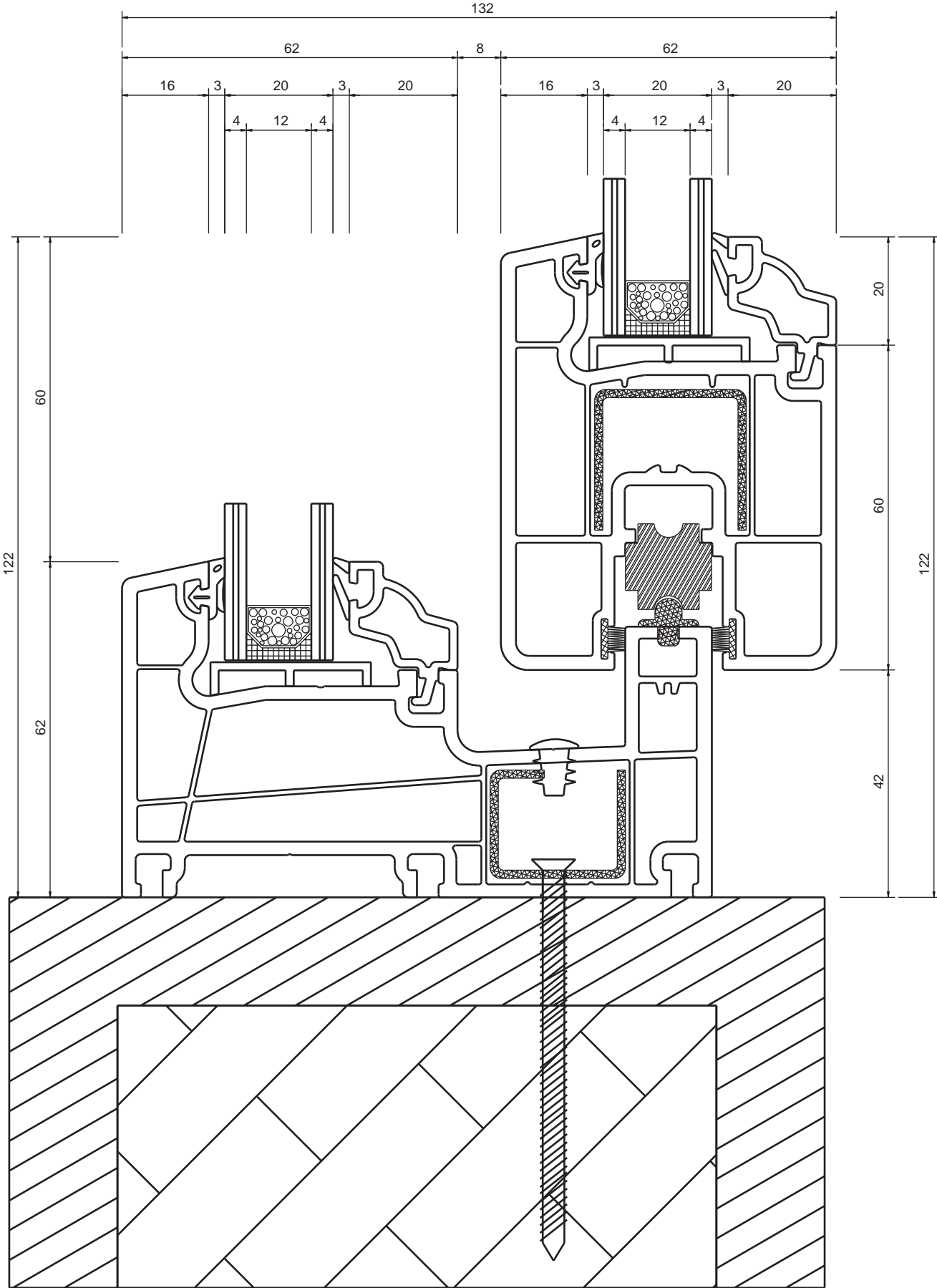
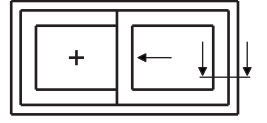

S-863 SÜRME SERİSİ MONTAJ DETAYI

S-863 SLIDING SERIES MOUNTING DETAIL

Ölçek 1/1 Scale



www.mywin.com.tr

BESE METAL ve PLASTİK
teknik dökümanlarda değişiklik
yapma hakkını saklı tutar.
reserves the right to make any
modifications on technical
documents.

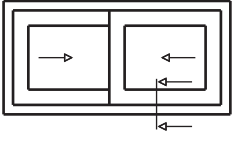

S-863 SÜRME SERİSİ MONTAJ DETAYI

S-863 SLIDING SERIES MOUNTING DETAIL

Ölçek 1/1 Scale



www.mywin.com.tr

BESE METAL ve PLASTİK
teknik dokümanlarda değişiklik
yapma hakkını saklı tutar.
reserves the right to make any
modifications on technical
documents.

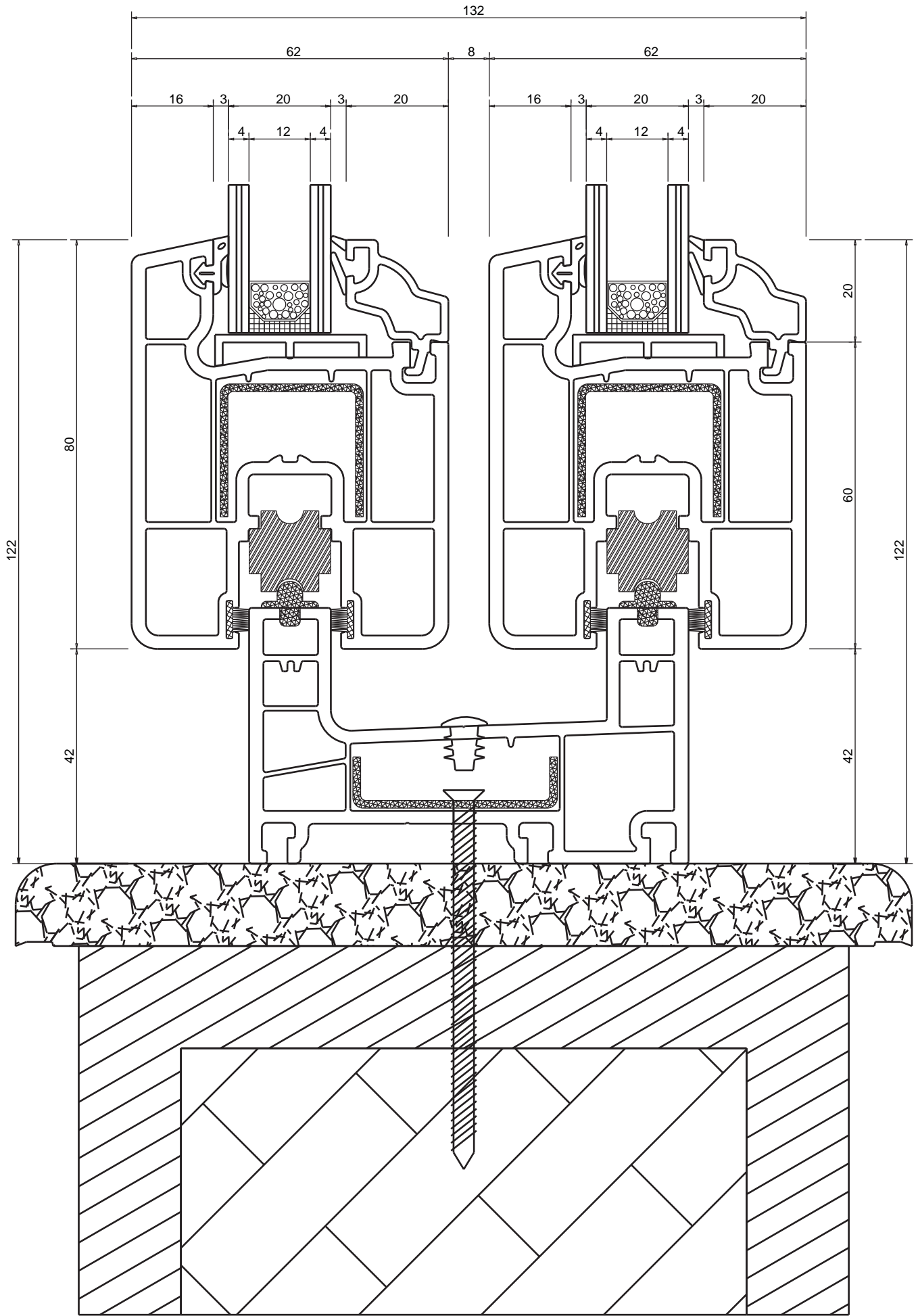

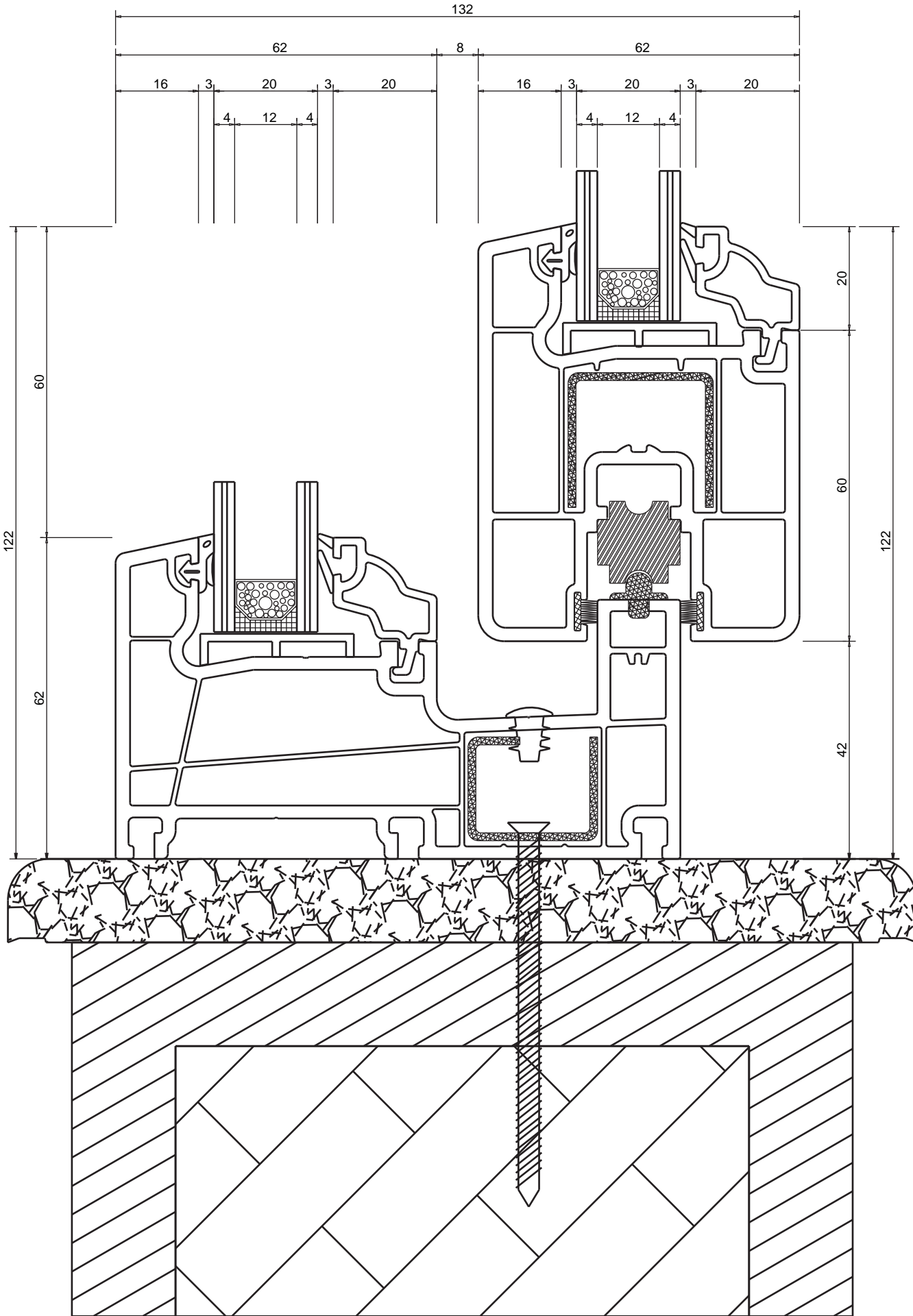
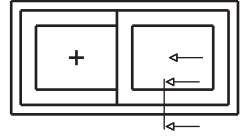

S-863 SÜRME SERİSİ MONTAJ DETAYI

S-863 SLIDING SERIES MOUNTING DETAIL

Ölçek 1/1 Scale



www.mywin.com.tr

BESE METAL ve PLASTİK
teknik dökümanlarda değişiklik
yapma hakkını saklı tutar.
reserves the right to make any
modifications on technical
documents.

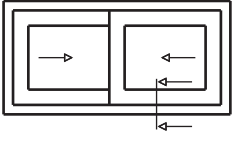

S-863 SÜRME SERİSİ SU TAHLİYE DETAYI

S-863 SLIDING SERIES WATER DRAINAGE DETAIL

Ölçek 1/1 Scale



PVC Window & Door Systems

www.mywin.com.tr

BESE METAL ve PLASTİK
teknik dökümanlarda değişiklik
yapma hakkını saklı tutar.
reserves the right to make any
modifications on technical
documents.

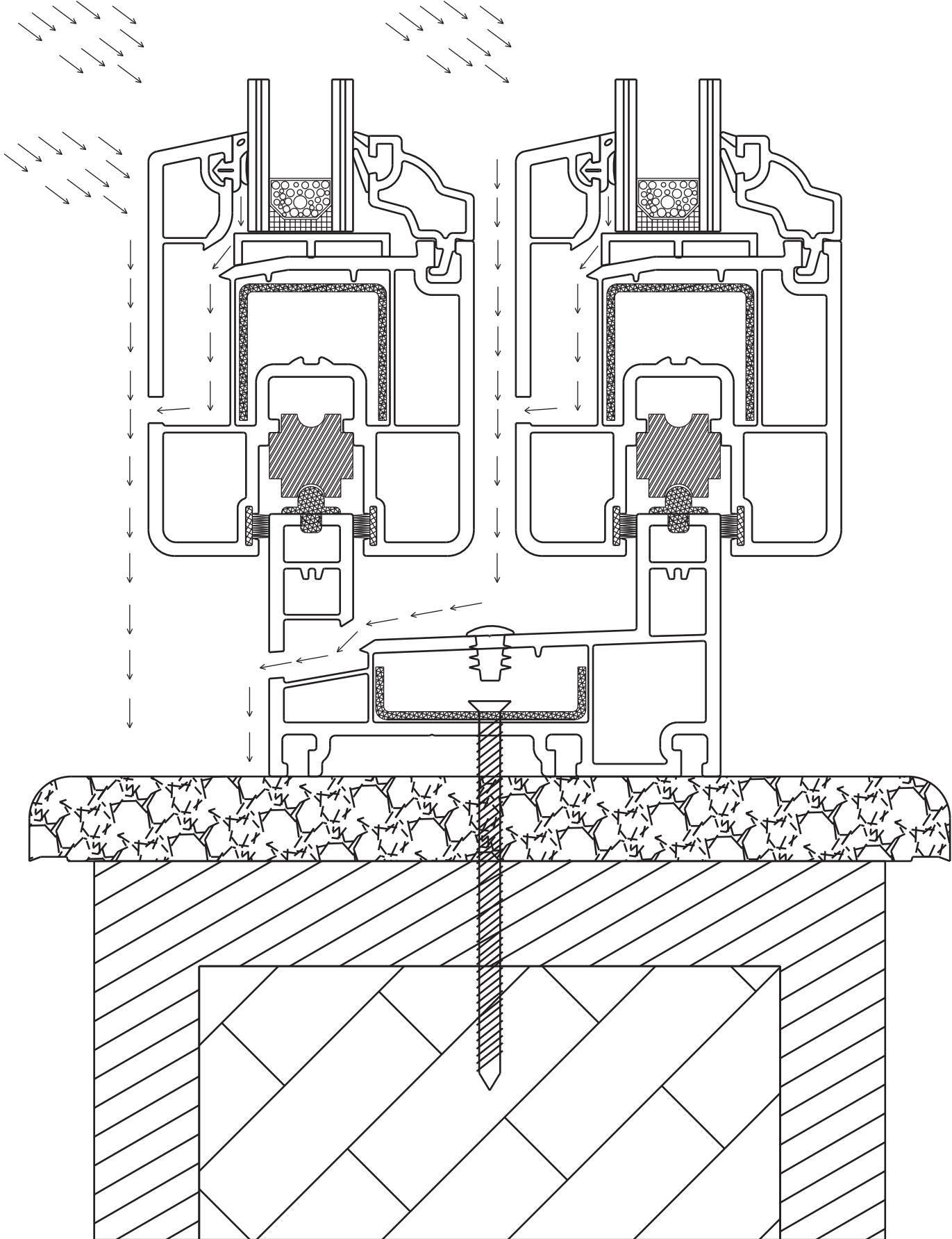

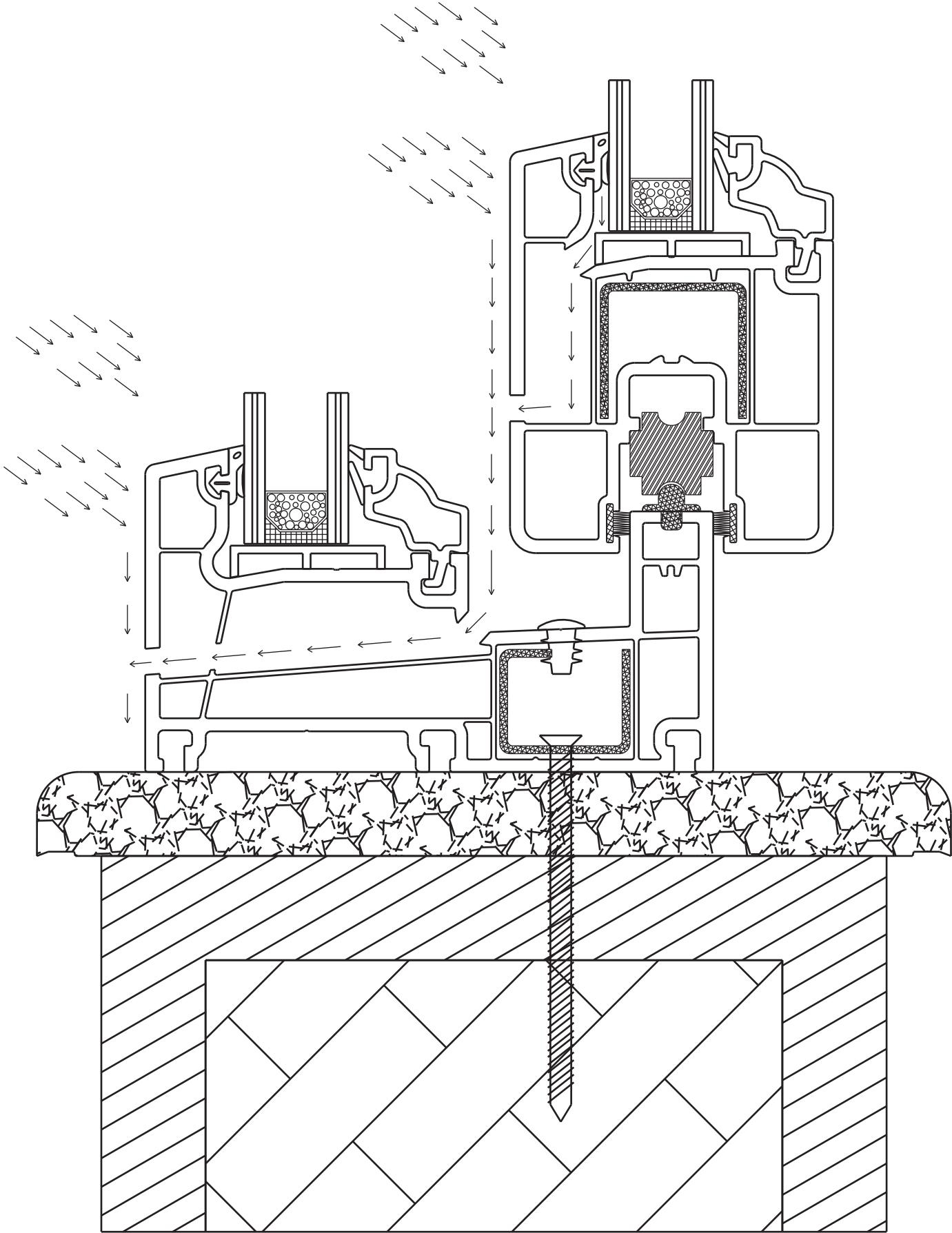
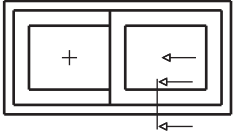

S-863 SÜRME SERİSİ SU TAHLİYE DETAYI
S-863 SLIDING SERIES WATER DRAINAGE DETAIL

Ölçek 1/1 Scale



www.mywin.com.tr

BESE METAL ve PLASTİK
teknik dökümanlarda değişiklik
yapma hakkını saklı tutar.
reserves the right to make any
modifications on technical
documents.

PVC Window & Door Systems



www.mywin.com.tr



S-623

sürme serisi profilleri
sliding series profiles

S-623 SÜRME KASA PROFİLİ
Ürün Kodu / Product Code: 623.10.00.0
S-623 SIDING-FRAME PROFILE

Ölçek 1/1 Scale



www.mywin.com.tr

BESE METAL ve PLASTİK
teknik dokümanlarda değişiklik
yapma hakkını saklı tutar.
reserves the right to make any
modifications on technical
documents.

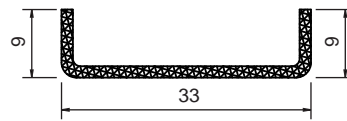
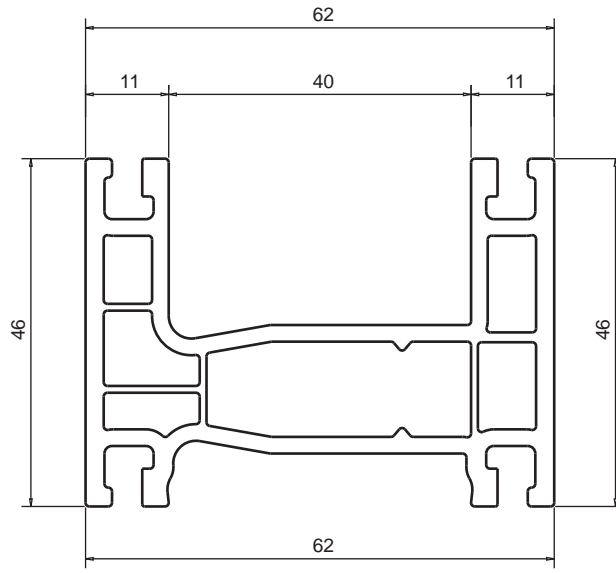

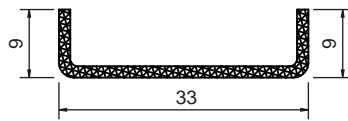
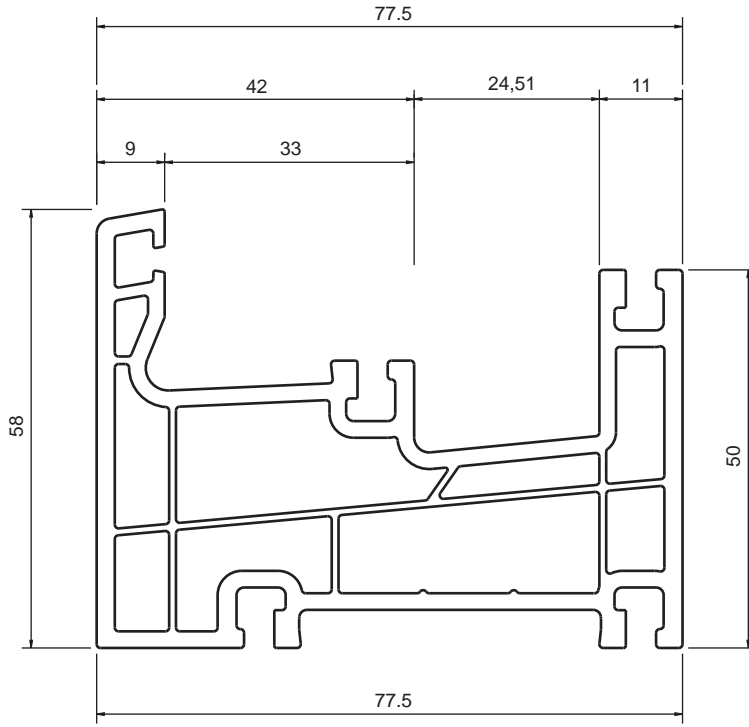

S-623 SÜRME SABÝT KASA PROFÝLÝ
Ürün Kodu / Product Code: 623.11.00.0
S-623 SLIDING FIXED FRAME PROFILE

Ölçek 1/1 Scale



www.mywin.com.tr

BESE METAL ve PLASTİK
teknik dökümanlarda değışiklik
yapma hakkını saklı tutar.
reserves the right to make any
modifications on technical
documents.

S-623 SÜRME KANAT PROFİLİ
Ürün Kodu / Product Code: 623.30.00.0
S-623 SLIDING SASH PROFILE

Ölçek 1/1 Scale



www.mywin.com.tr

BESE METAL ve PLASTİK
teknik dökümanlarda değişiklik
yapma hakkını saklı tutar.
reserves the right to make any
modifications on technical
documents.

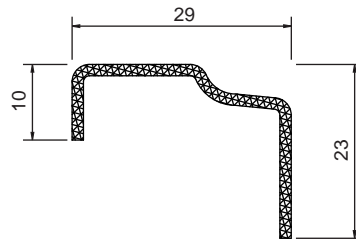
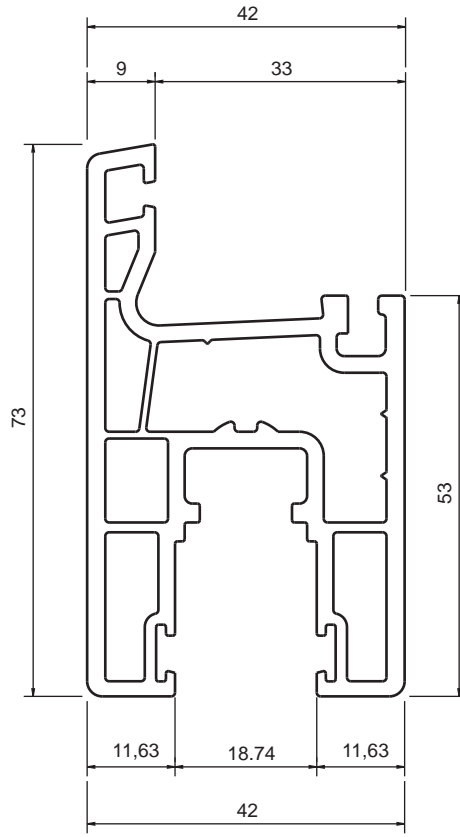

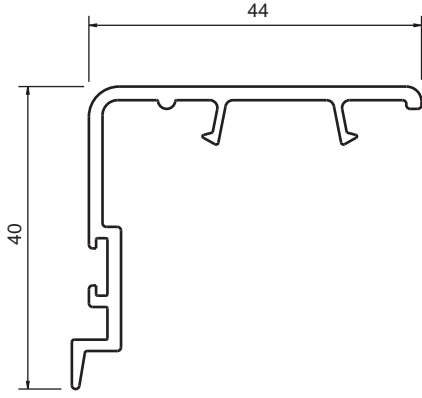

S-623 SÜRME İNTERLOK
Ürün Kodu / Product Code: 623.70.00.0
S-623 SLIDING INTERLOCK

Ölçek 1/1 Scale



www.mywin.com.tr

BESE METAL ve PLASTİK
teknik dökümanlarda değişiklik
yapma hakkını saklı tutar.
reserves the right to make any
modifications on technical
documents.



S-623 SÜRME PVC RAY KAPAMA & PVC ÇITA KANALI KAPAMA

Ürün Kodu / Product Code: 623.73.00.0

S-623 SLIDING PVC RAY COVER & PVC BEAD CHANNEL COVER



S-623 SÜRME & S-863 SÜRME SERİLERİ ALUMİNYUM RAY

Ürün Kodu / Product Code: 900.A01.00.0

S-623 SLIDING & S-863 SLIDING SERIES ALUMINIUM RAIL

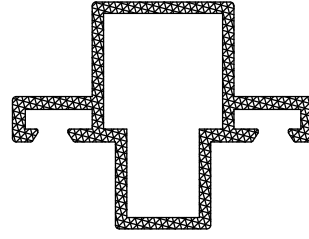

S-623 SÜRME & S-863 SÜRME SERİLERİ ALUMİNYUM KANAT BİRLEŞTİRME

Ürün Kodu / Product Code: 900.A02.00.0

S-623 SLIDING & S-863 SLIDING SERIES ALUMINIUM SASH COVER

Ölçek 1/1 Scale

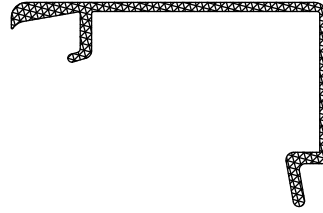

S-623 SÜRME SERİ ALUMİNYUM EŞİK

Ürün Kodu / Product Code: 900.A03.00.0

S-623 SLIDING SERIE ALUMINIUM THRESHOLD



www.mywin.com.tr

BESE METAL ve PLASTİK
teknik dökümanlarda değişiklik
yapma hakkını saklı tutar.
reserves the right to make any
modifications on technical
documents.

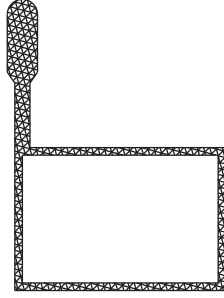

S-623 SÜRME SERÝALUMÝNYUM SÝNEKLÝK KASA PROFÝLY

Ürün Kodu / Product Code: 900.A05.00.0

S-623 SLIDING SERIE ALUMINIUM FLYSWATTER FRAME PROFÝLE

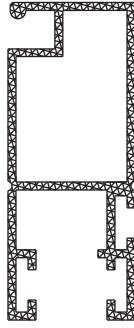

S-623 SÜRME SERÝALUMÝNYUM SÝNEKLÝK KANAT PROFÝLY

Ürün Kodu / Product Code: 900.A06.00.0

S-623 SLIDING SERIE ALUMINIUM FLYSWATTER SASH PROFÝLE

Ölçek 1/1 Scale



www.mywin.com.tr

BESE METAL ve PLASTİK
teknik dökümanlarda değışiklik
yapma hakkını saklı tutar.
reserves the right to make any
modifications on technical
documents.

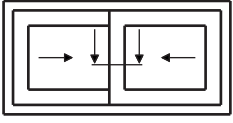

**S-623 SÜRME KANAT & SÜRME İNTERLOK &
20mm İSICAM ÇITASI BİRLEŞİM DETAYI**
S-623 SLIDING SASH & SLIDING INTERLOCK &
DOUBLE GLASS BEAD 20mm APPLICATION DETAIL

Ölçek 1/1 Scale

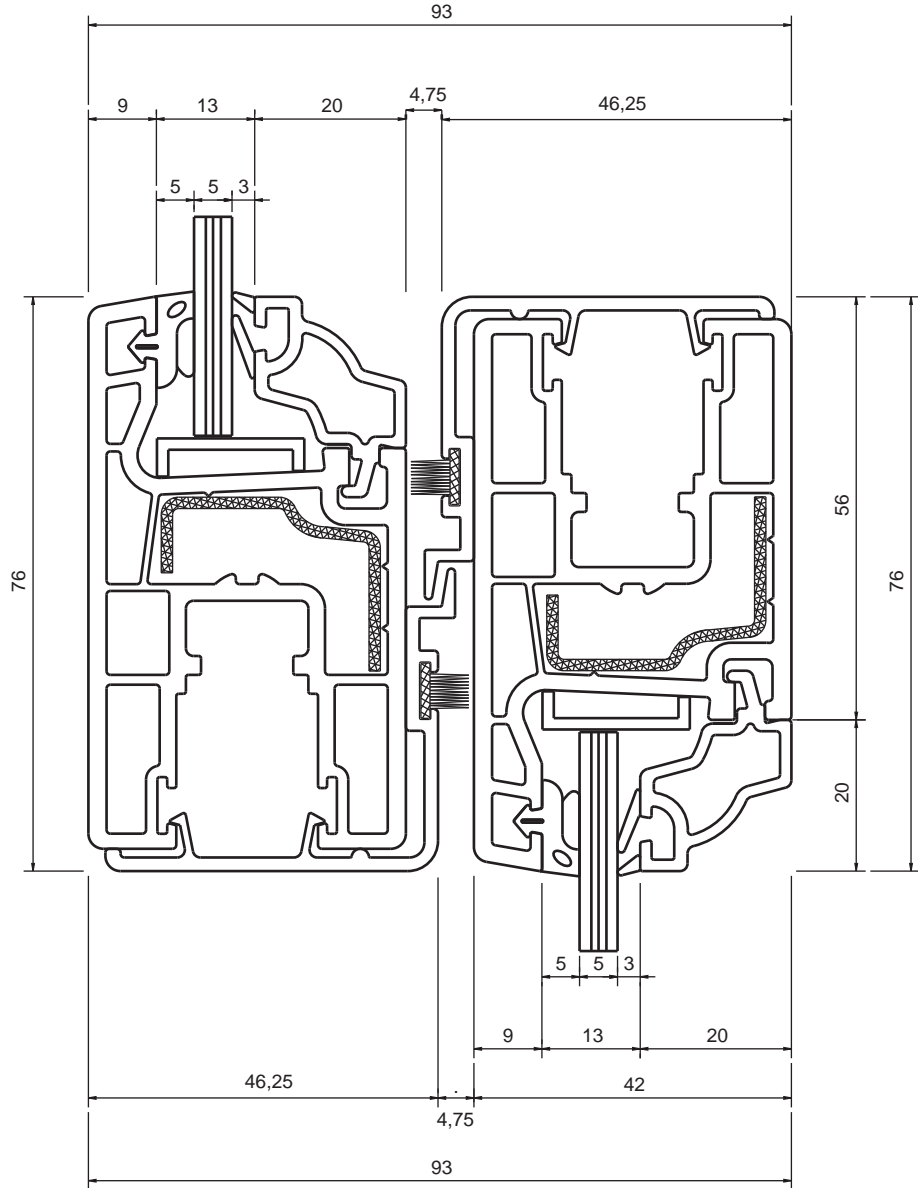

www.mywin.com.tr

BESE METAL ve PLASTİK
teknik dokümanlarda değişiklik
yapma hakkını saklı tutar.
reserves the right to make any
modifications on technical
documents.

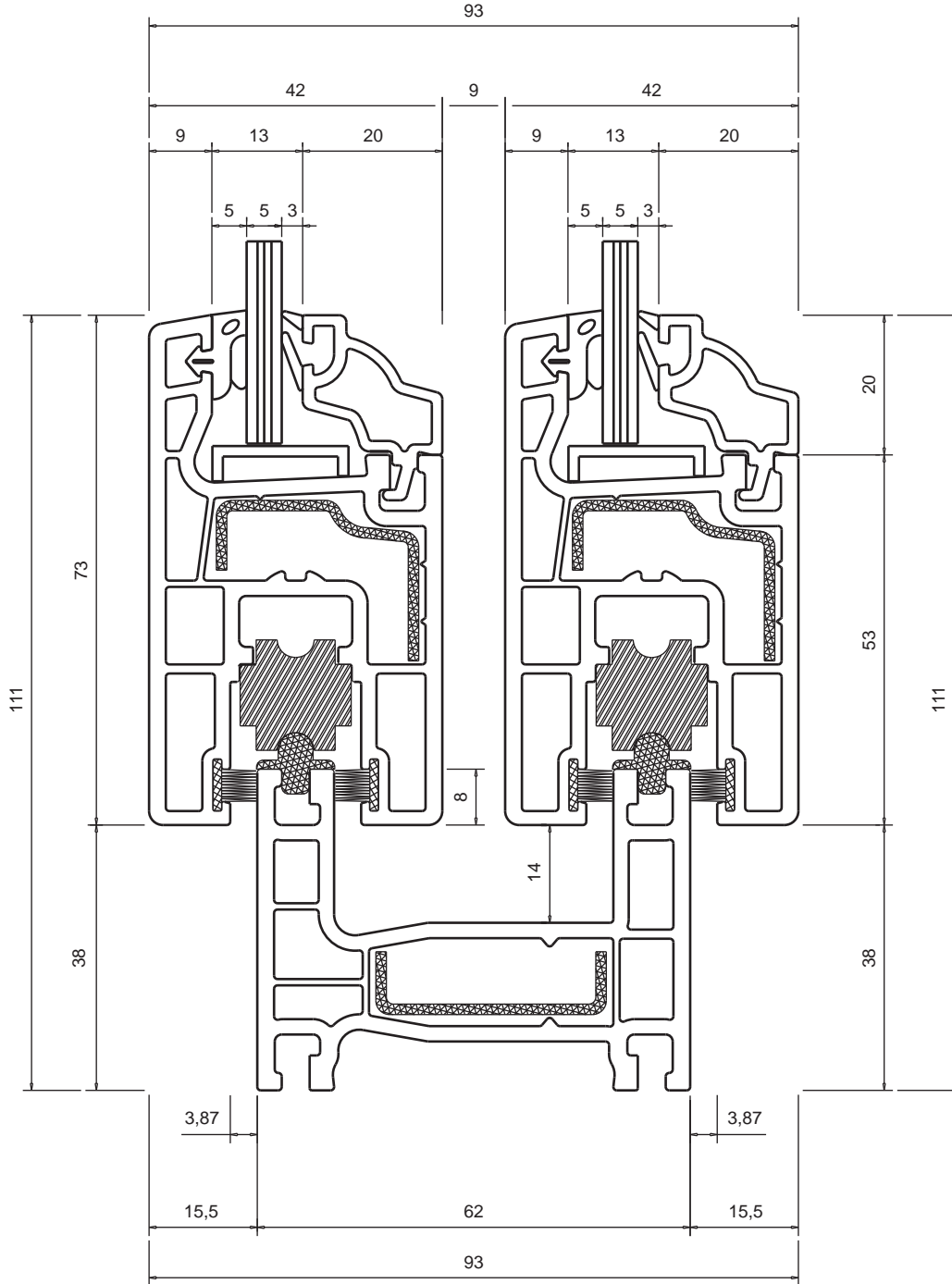
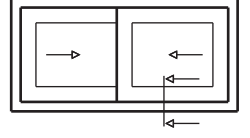

**S-623 SÜRME KASA & SÜRME KANAT &
20mm ISICAM ÇITASI BİRLEPİM DETAYI**
S-623 SLIDING FRAME & SLIDING SASH &
DOUBLE GLASS BEAD 20mm APPLICATION DETAIL

Ölçek 1/1 Scale



www.mywin.com.tr

BESE METAL ve PLASTİK
teknik dökümanlarda değışiklik
yapma hakkını saklı tutar.
reserves the right to make any
modifications on technical
documents.

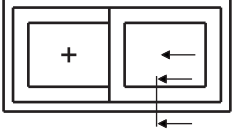

**S-623 SÜRME KASA & SÜRME KANAT &
30mm ÜÇLÜ CAM ÇITASI BİRLEŞİM DETAYI**
S-623 SLIDING FRAME & SLIDING SASH &
TRIPLE GLASS BEAD 30mm APPLICATION DETAIL

Ölçek 1/1 Scale

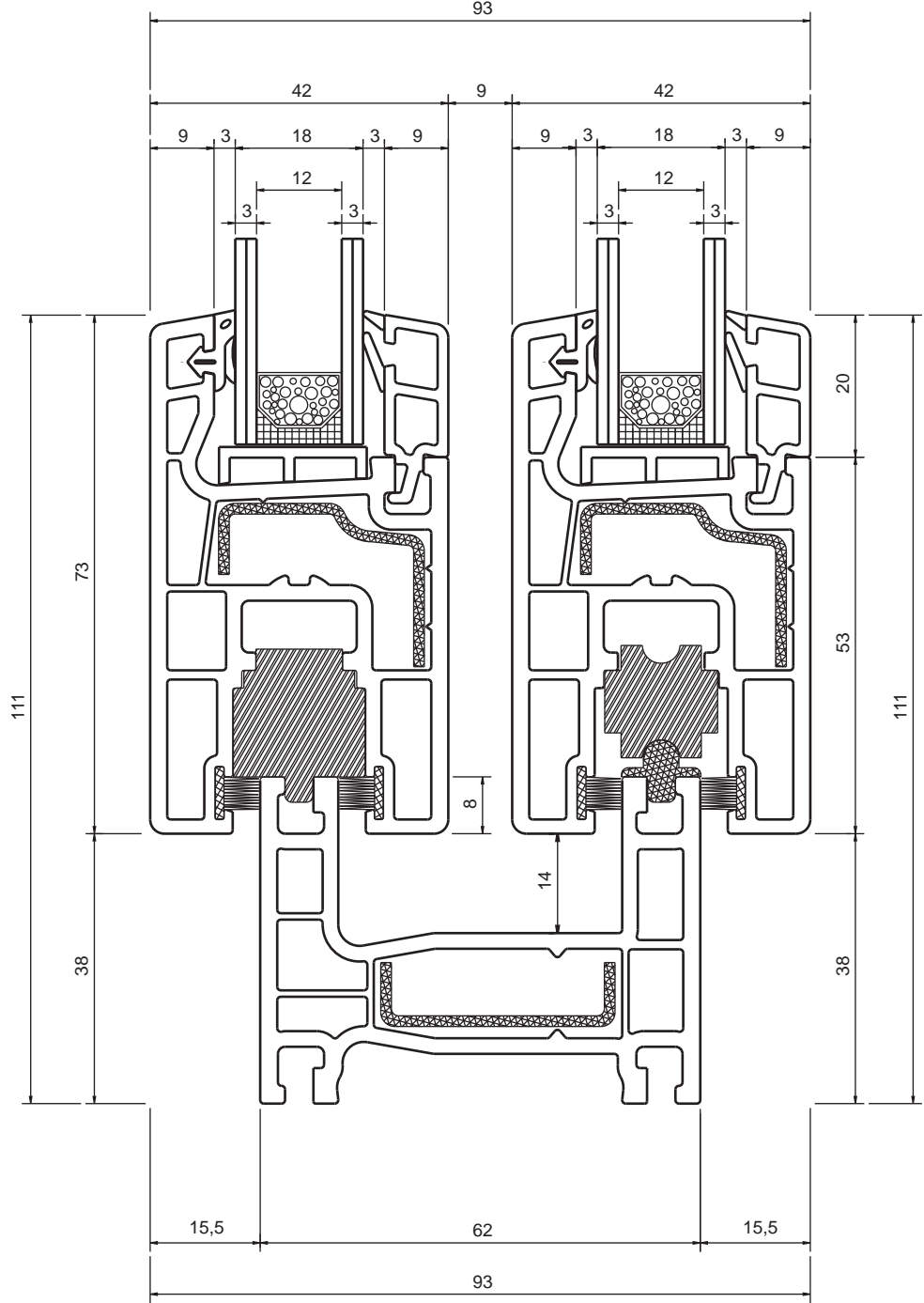

www.mywin.com.tr

BESE METAL ve PLASTİK
teknik dökümanlarda değişiklik
yapma hakkını saklı tutar.
reserves the right to make any
modifications on technical
documents.

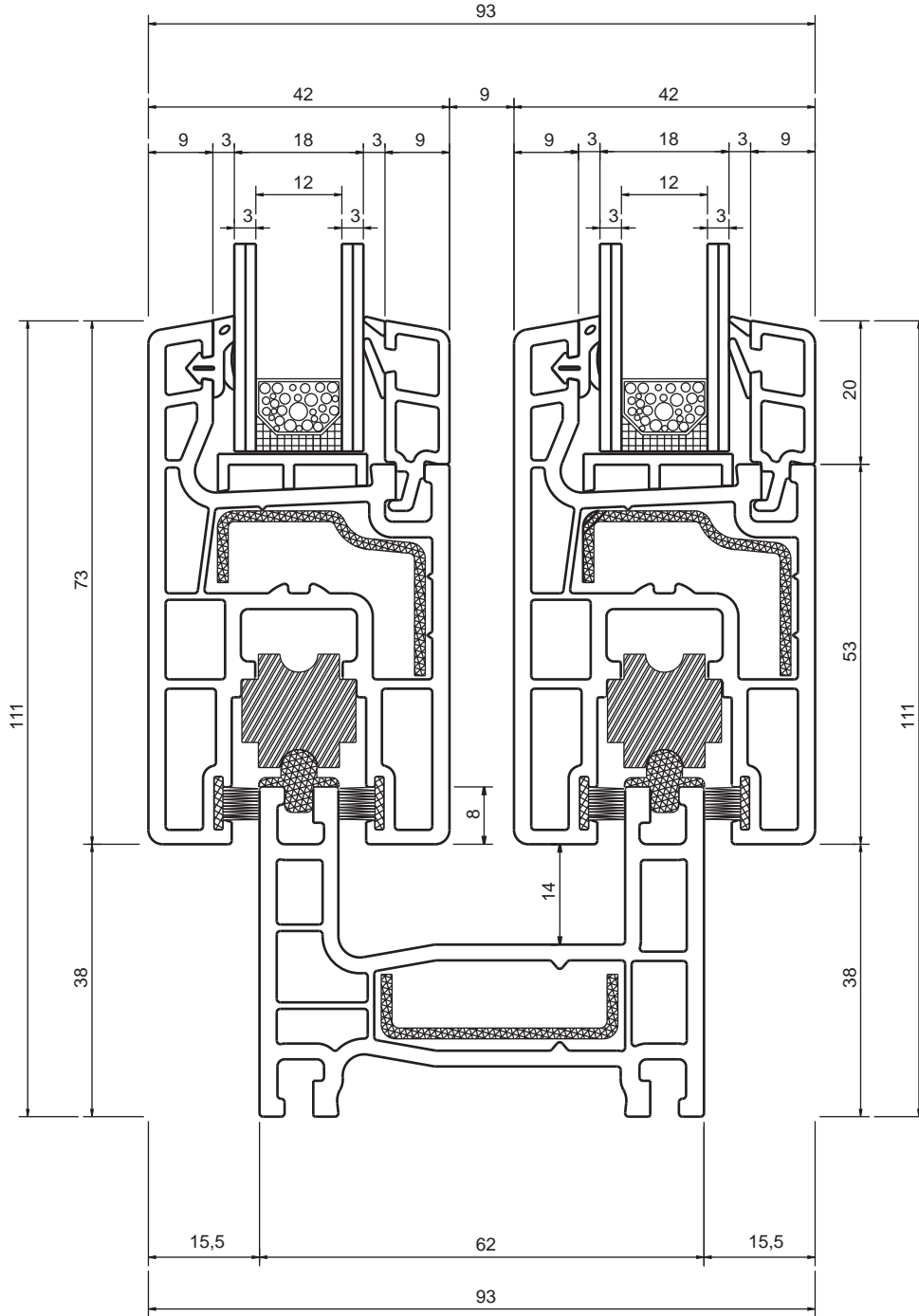
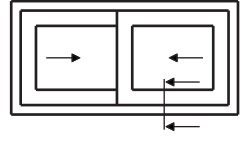

**S-623 SÜRME KASA & SÜRME KANAT &
30mm ÜÇLÜ CAM ÇITASI BİRLEPİM DETAYI**
S-623 SLIDING FRAME & SLIDING SASH &
TRIPLE GLASS BEAD 30mm APPLICATION DETAIL

Ölçek 1/1 Scale



www.mywin.com.tr

BESE METAL ve PLASTİK
teknik dökümanlarda değişiklik
yapma hakkını saklı tutar.
reserves the right to make any
modifications on technical
documents.

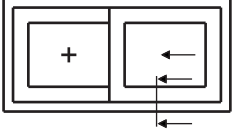

**S-623 SÜRME SABİT KASA & SÜRME KANAT &
20mm ISICAM ÇITASI BİRLEŞİM DETAYI**
S-623 SLIDING FIXED FRAME & SLIDING SASH &
DOUBLE GLASS BEAD 20mm APPLICATION DETAIL

Ölçek 1/1 Scale

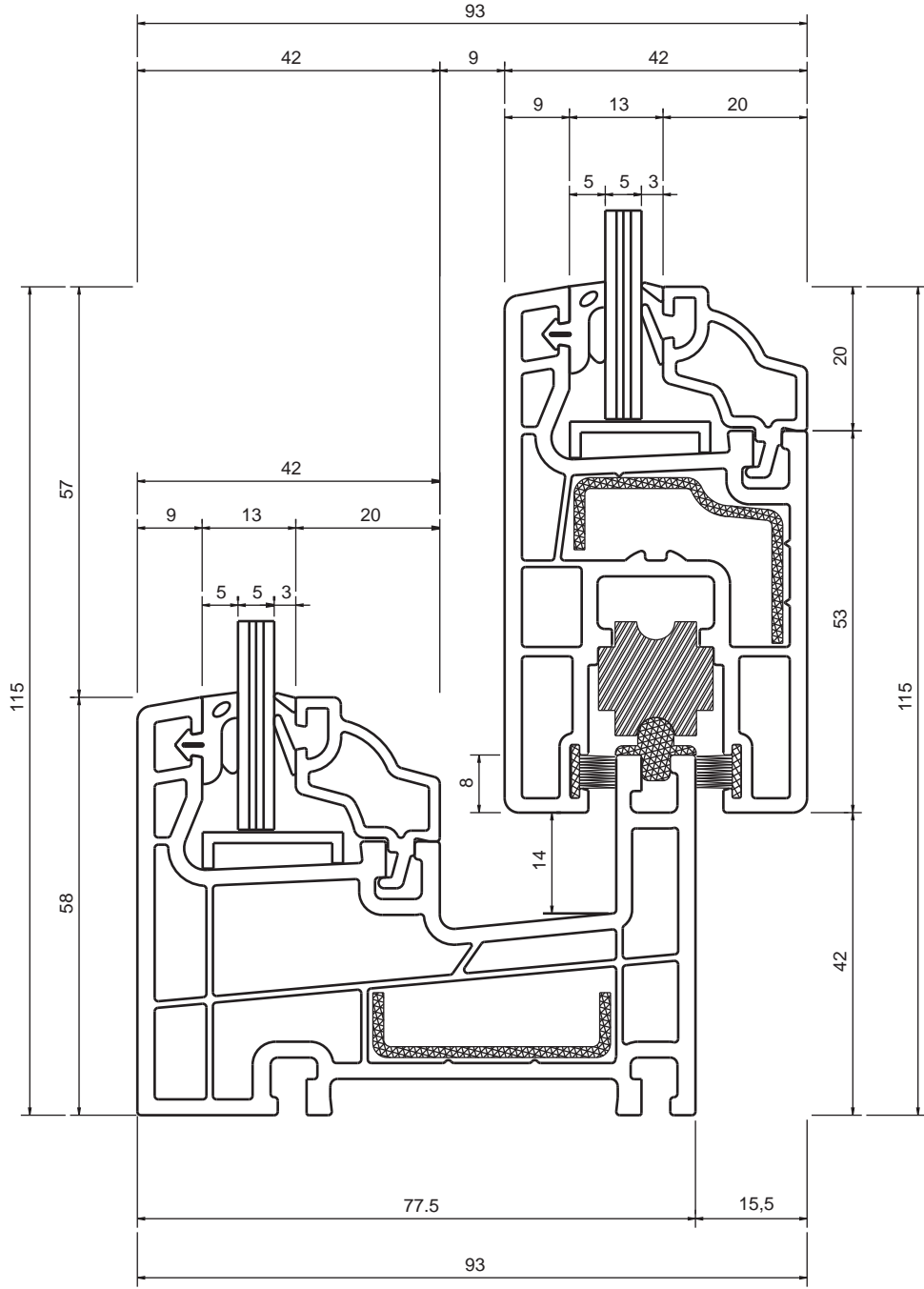

www.mywin.com.tr

BESE METAL ve PLASTİK
teknik dokümanlarda değişiklik
yapma hakkını saklı tutar.
reserves the right to make any
modifications on technical
documents.

S-623 SÜRME KANAT & ALÜMİNYUM KANAT BİRLEŞTİRME & SÜRME KANAT BİRLEŞİM DETAYI
S-623 SLIDING SASH & ALUMINIUM SASH CONNECTER & SLIDING SASH APPLICATION DETAIL

Ölçek 1/1 Scale



www.mywin.com.tr

BESE METAL ve PLASTİK teknik dökümanlarda değişiklik yapma hakkını saklı tutar.
reserves the right to make any modifications on technical documents.

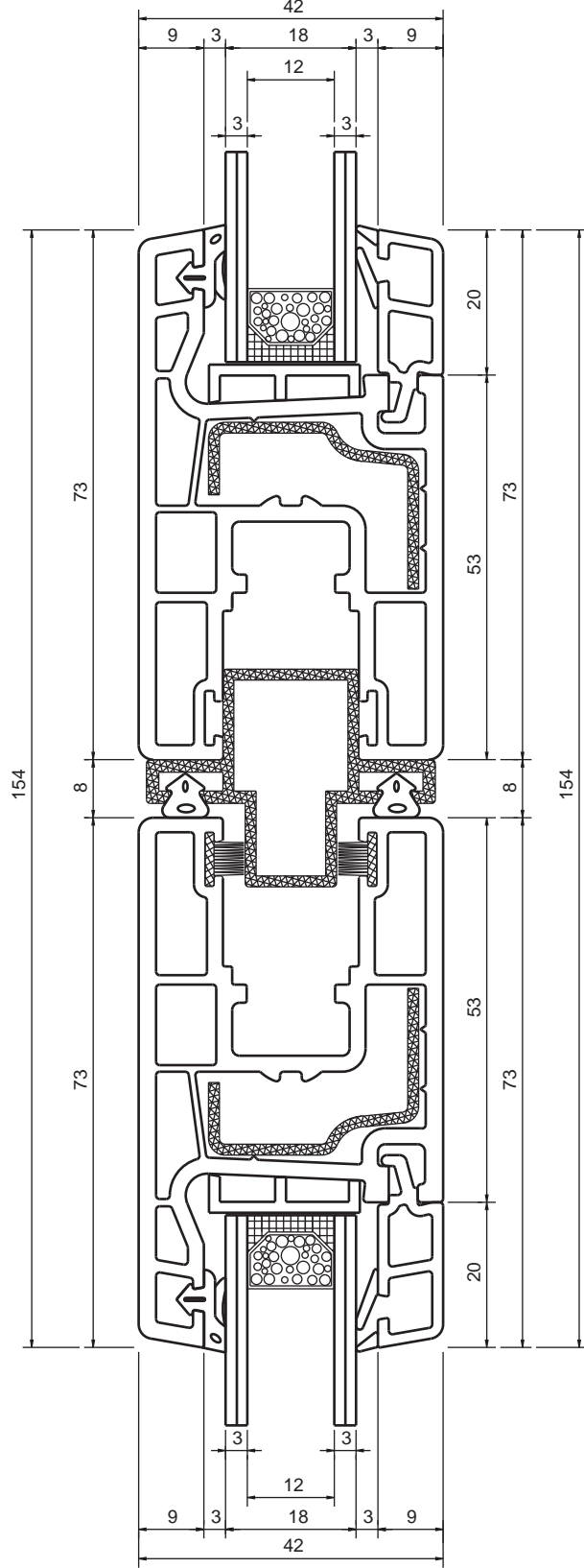
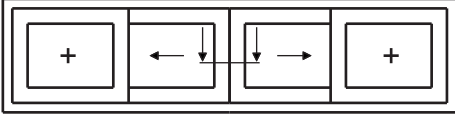

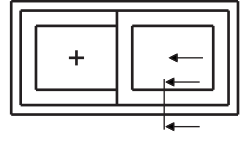
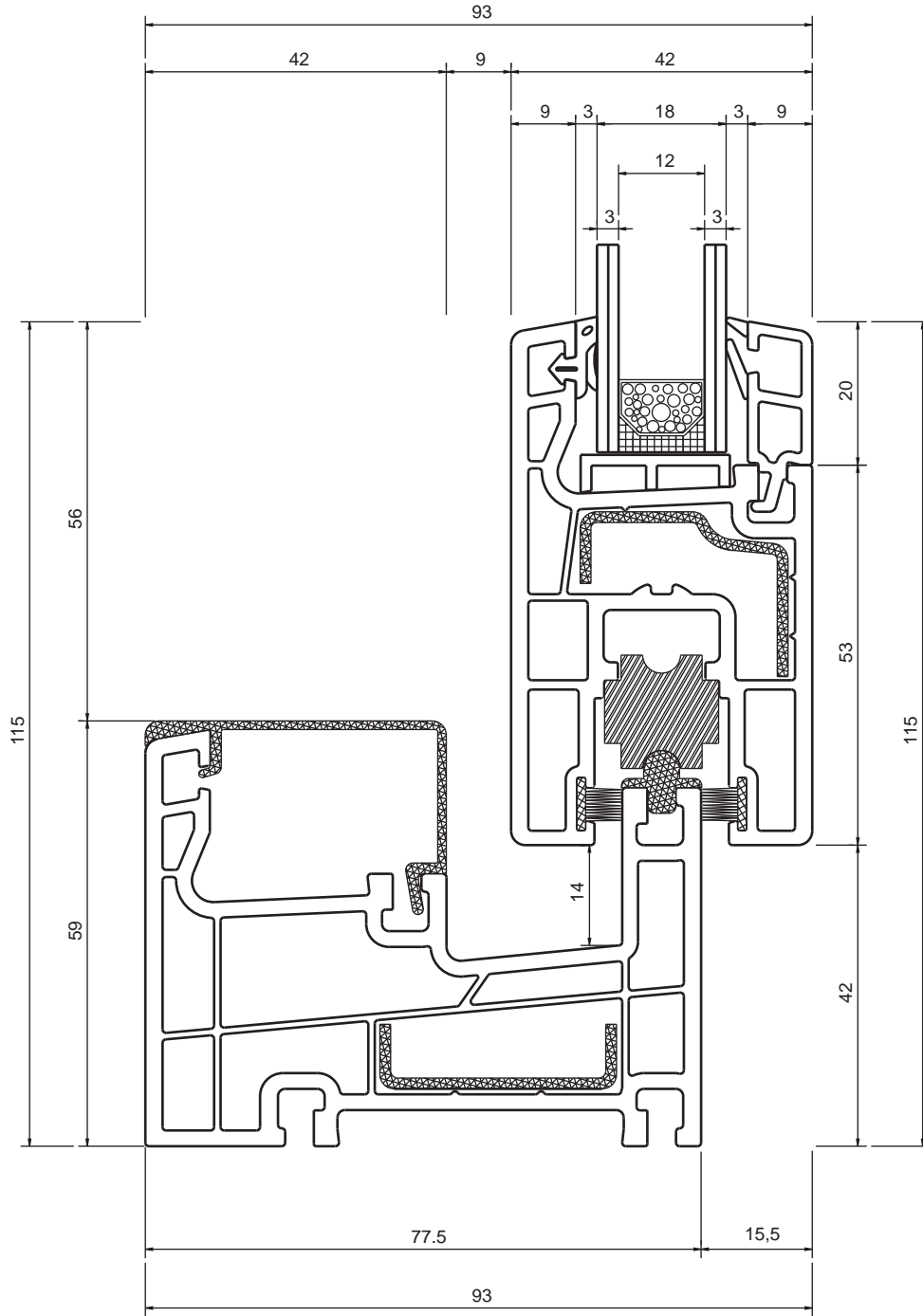

S-623 SÜRME SABİT KASA & ALÜMİNYUM EPİK PROFİLİ &
 S-623 SÜRME KANAT BİRLEŞİM DETAYI
 S-623 SLIDING FIXED FRAME & ALUMINIUM THRESHOLD &
 S-623 SLIDING SASH APPLICATION DETAIL

Ölçek 1/1 Scale

mywin[®]
 PVC Window & Door Systems

www.mywin.com.tr

BESE METAL ve PLASTİK
 teknik dökümanlarda değişiklik
 yapma hakkını saklı tutar.
 reserves the right to make any
 modifications on technical
 documents.

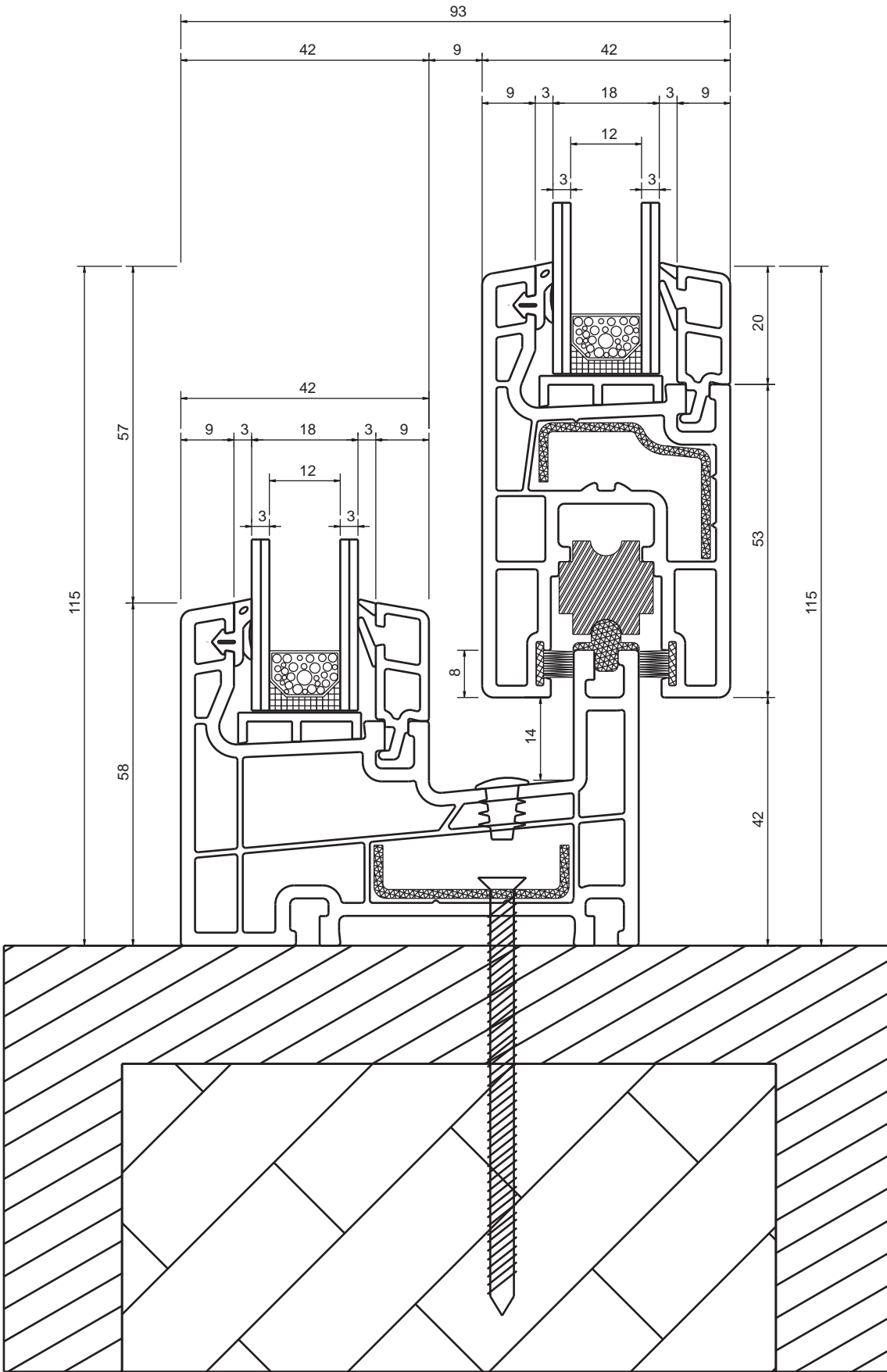
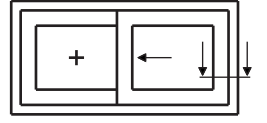

S-623 SÜRME SERİSİ MONTAJ DETAYI

S-623 SLIDING SERIES MOUNTING DETAIL

Ölçek 1/1 Scale



PVC Window & Door Systems

www.mywin.com.tr

BESE METAL ve PLASTİK
teknik dökümanlarda değişiklik
yapma hakkını saklı tutar.
reserves the right to make any
modifications on technical
documents.

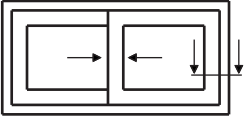

S-623 SÜRME SERİSİ MONTAJ DETAYI

S-623 SLIDING SERIES MOUNTING DETAIL

Ölçek 1/1 Scale



PVC Window & Door Systems

www.mywin.com.tr

BESE METAL ve PLASTİK
teknik dokümanlarda değişiklik
yapma hakkını saklı tutar.
reserves the right to make any
modifications on technical
documents.

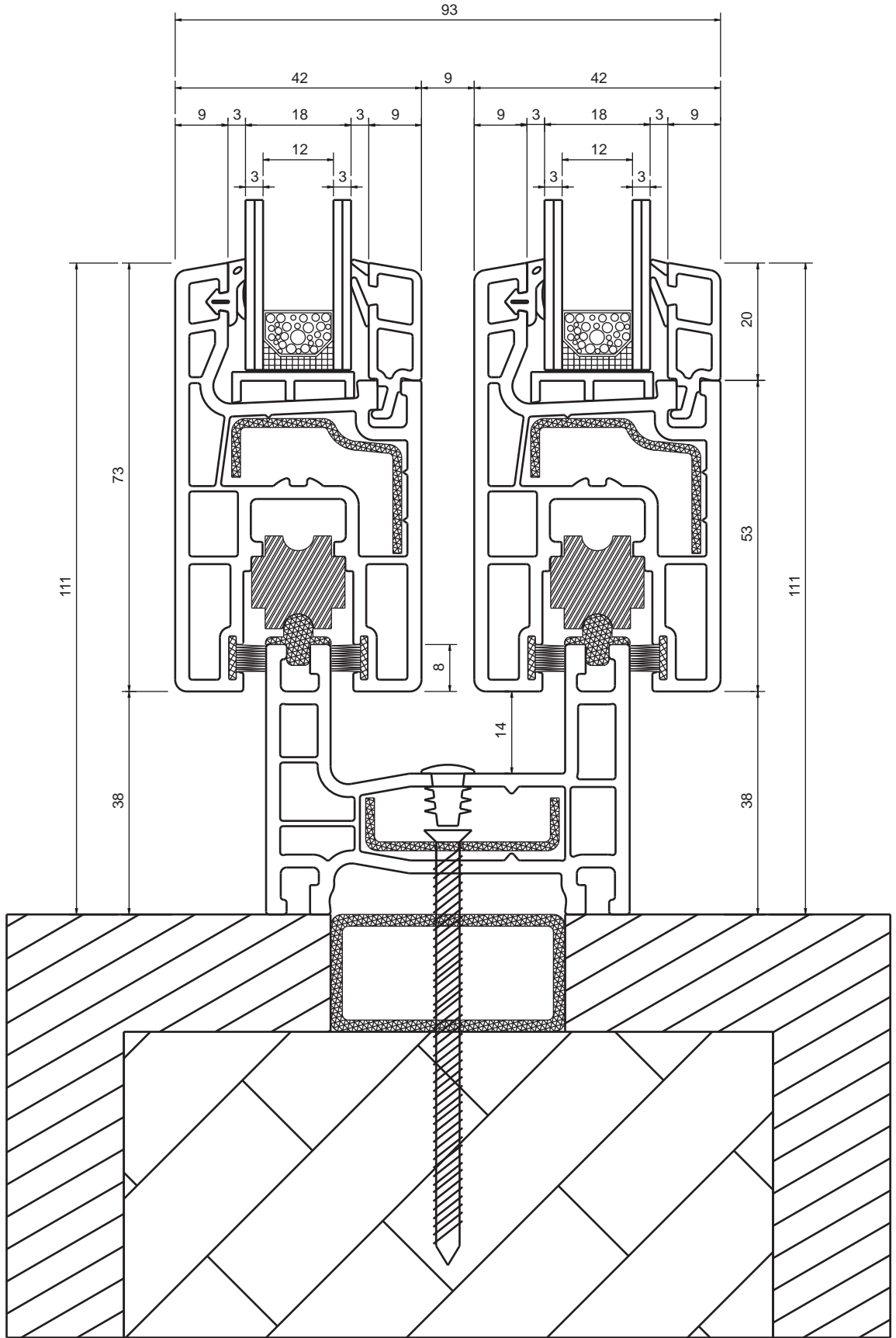

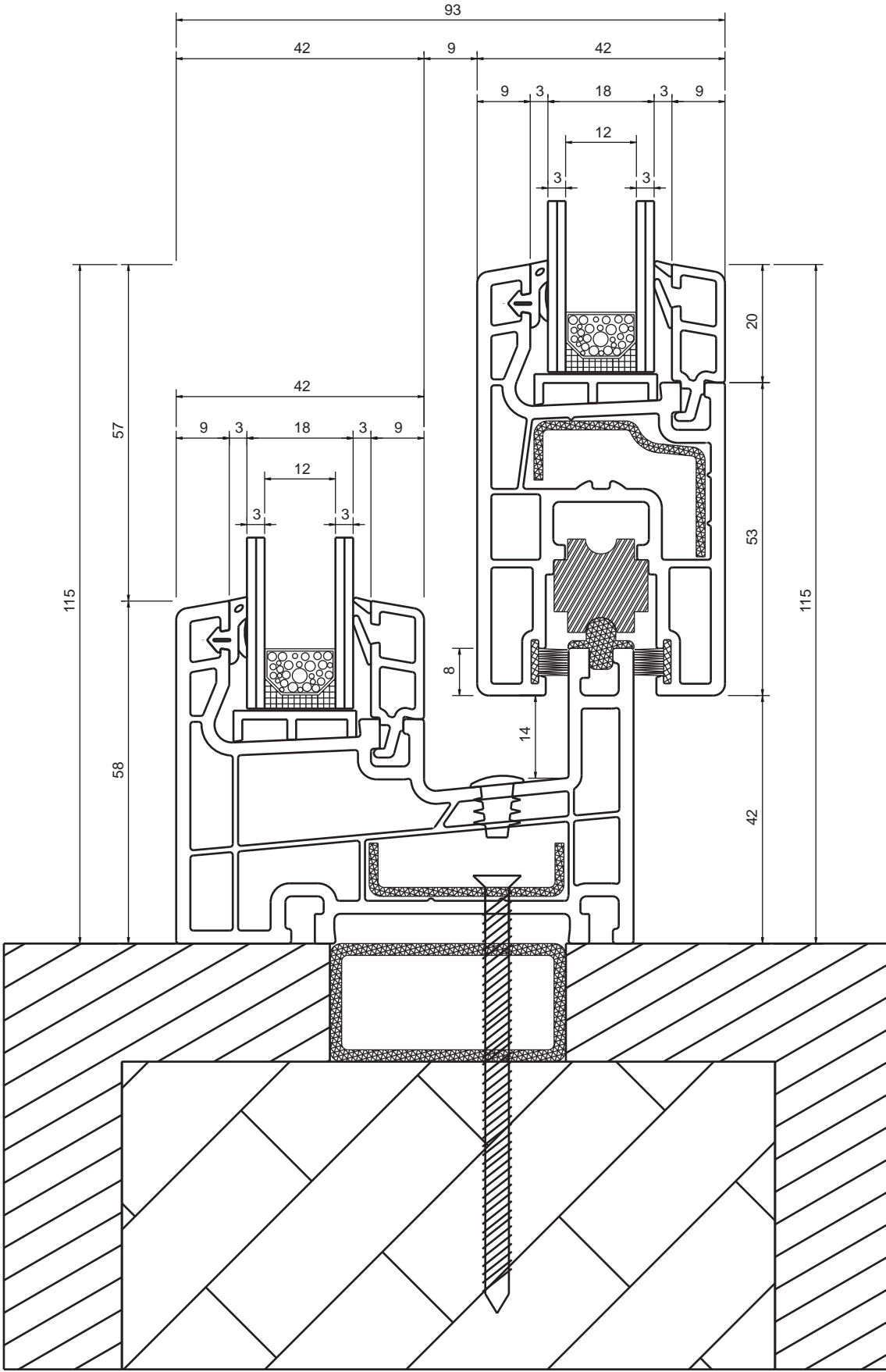
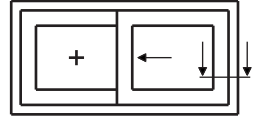

S-623 SÜRME SERİSİ MONTAJ DETAYI

S-623 SLIDING SERIES MOUNTING DETAIL

Ölçek 1/1 Scale



www.mywin.com.tr

BESE METAL ve PLASTİK
teknik dökümanlarda değişiklik
yapma hakkını saklı tutar.
reserves the right to make any
modifications on technical
documents.

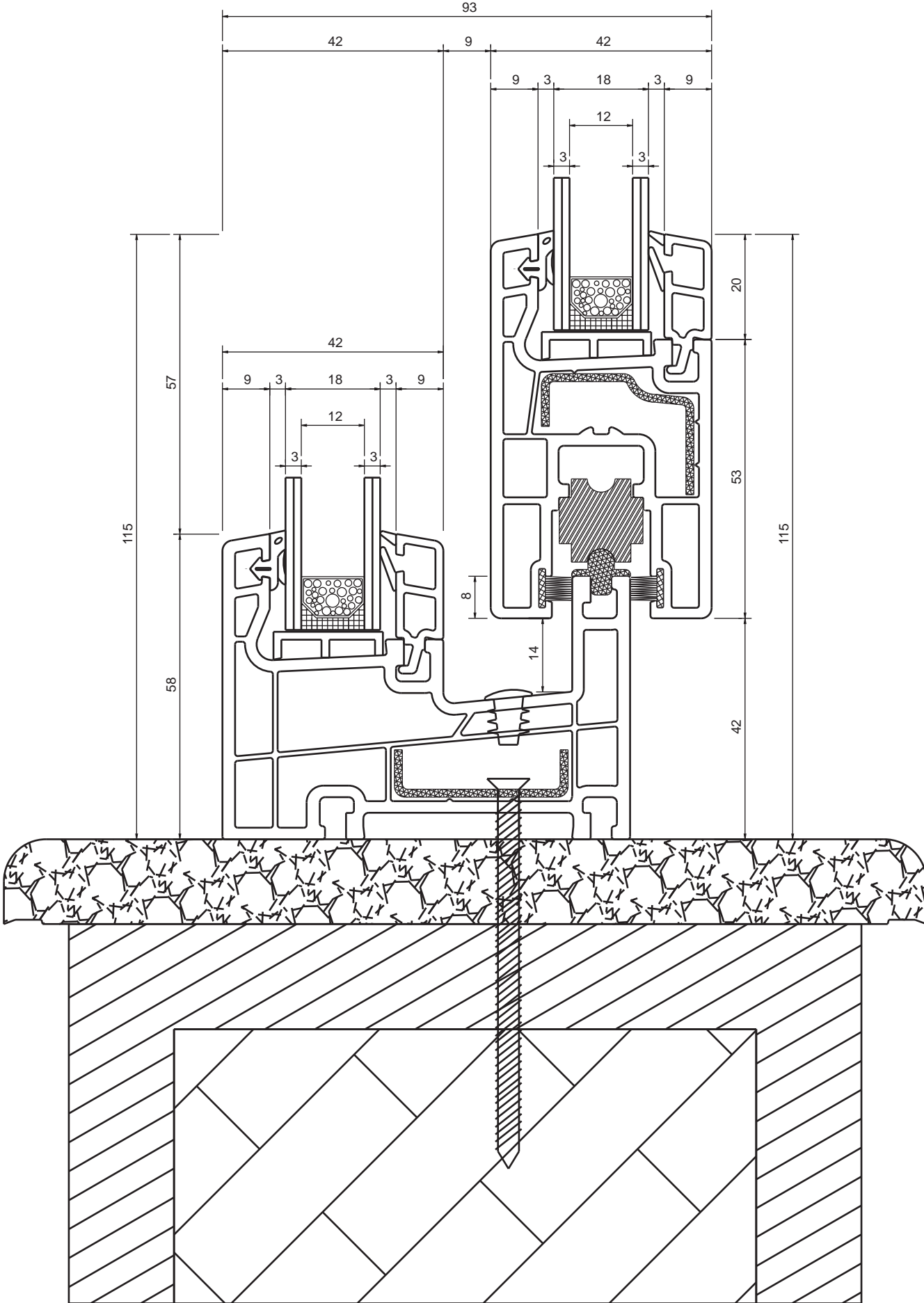
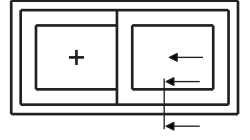

S-623 SÜRME SERİSİ MONTAJ DETAYI

S-623 SLIDING SERIES MOUNTING DETAIL

Ölçek 1/1 Scale



www.mywin.com.tr

BESE METAL ve PLASTİK
teknik dökümanlarda değişiklik
yapma hakkını saklı tutar.
reserves the right to make any
modifications on technical
documents.

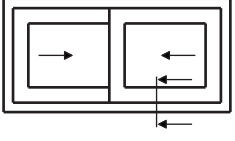

S-623 SÜRME SERİSİ SU TAHLİYE DETAYI

S-623 SLIDING SERIES WATER DRAINAGE DETAIL

Ölçek 1/1 Scale



PVC Window & Door Systems

www.mywin.com.tr

BESE METAL ve PLASTİK
teknik dökümanlarda değişiklik
yapma hakkını saklı tutar.
reserves the right to make any
modifications on technical
documents.

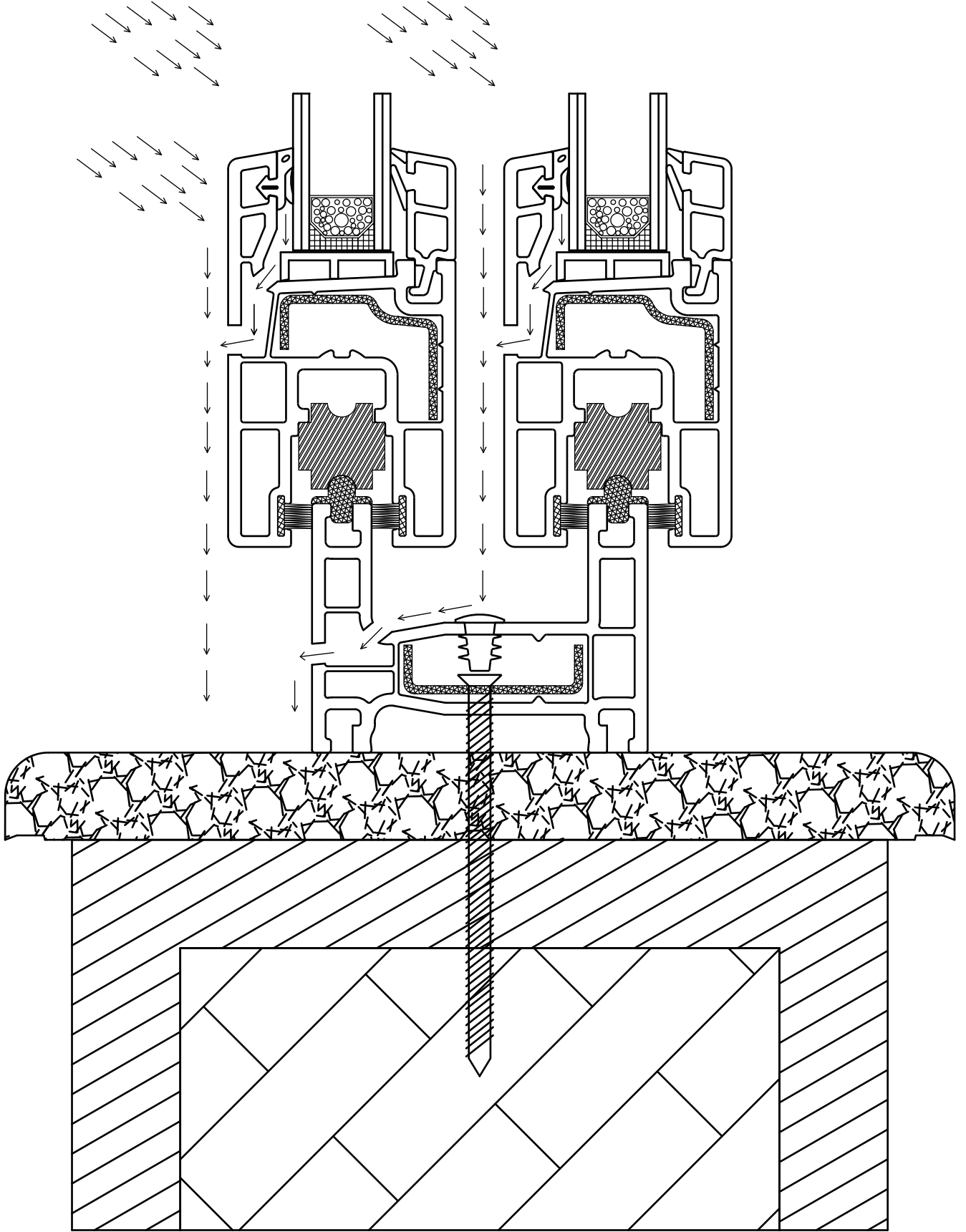

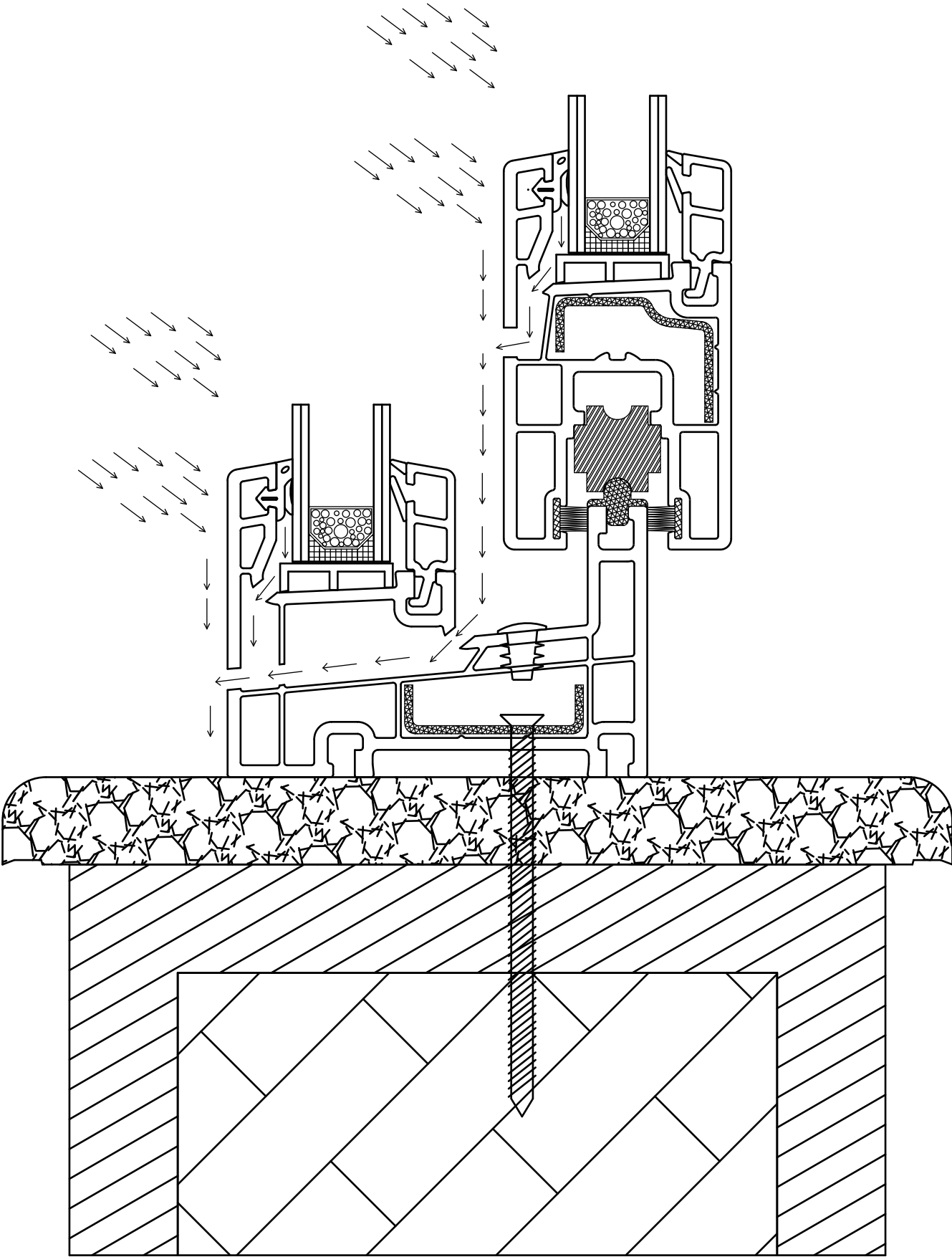
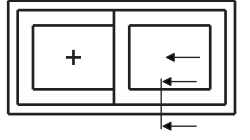

S-623 SÜRME SERİSİ SU TAHLİYE DETAYI
S-623 SLIDING SERIES WATER DRAINAGE DETAIL

Ölçek 1/1 Scale



www.mywin.com.tr

BESE METAL ve PLASTİK
teknik dökümanlarda değişiklik
yapma hakkını saklı tutar.
reserves the right to make any
modifications on technical
documents.

DESTEK SACI TÝPLERÝ ve KULLANIM ALANLARI
SUPPORT STEEL TYPES AND FIELDS OF USAGE

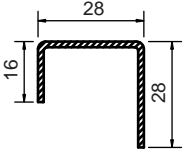
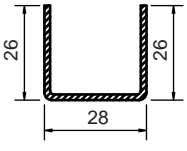
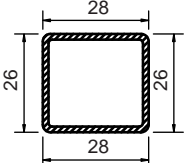
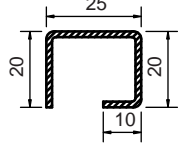
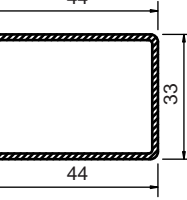
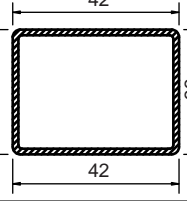
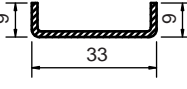
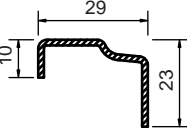
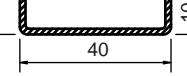
ÜRÜN KODU PRODUCT CODE	DESTEK SACI TÝPÝ SUPPORT STEEL TYPE	KALINLIK mm THICKNESS mm	AĐIRLIK kg/mt WEIGHT kg/mt	KULLANILDIĐI PROFÝLER USED-AT PROFILES
900.S01.12 900.S01.15 900.S01.20		1.20 mm 1.50 mm 2.00 mm	0,631 0,777 1,005	S-624 KANAT / S-624 SASH S-705 DAMLALIKLI KANAT / S-705 DRAINER SASH
900.S02.12 900.S02.15 900.S02.20		1.20 mm 1.50 mm 2.00 mm	0,707 0,871 1,130	S-624 KASA / S-624 FRAME S-624 ORTA KAYIT / S-624 MULLION S-705 KASA / S-705 FRAME S-705 ORTA KAYIT / S-705 MULLION S-863 SÜRME KANAT / S-705 SLIDING SASH
900.S03.12 900.S03.15 900.S03.20		1.20 mm 1.50 mm 2.00 mm	0,923 1,130 1,507	S-624 KASA / S-624 FRAME S-624 ORTA KAYIT / S-624 MULLION S-705 KASA / S-705 FRAME S-705 ORTA KAYIT / S-705 MULLION
900.S04.12 900.S04.15 900.S04.20		1.20 mm 1.50 mm 2.00 mm	0,631 0,777 1,036	S-624 HAREKETLÝ ORTA KAYIT / S-624 MOVING MULLION S-705 SÜRME SABÝT KASA / S-705 SLIDING FIXED FRAME S-705 PERVAZLI KASA / S-705 FRAME WITH BORDER
900.S05.12 900.S05.15 900.S05.20		1.20 mm 1.50 mm 2.00 mm	1,093 1,354 1,774	S-624 ÝÇE AÇILIM KAPI KANAT / S-624 IN SIDE DOOR SASH S-624 DIĐA AÇILIM KAPI KANAT / S-624 OUT SIDE DOOR SASH
900.S06.12 900.S06.15 900.S06.20		1.20 mm 1.50 mm 2.00 mm	1,319 1,625 2,167	S-624 ÝÇE AÇILIM KAPI KANAT / S-624 IN SIDE DOOR SASH S-624 DIĐA AÇILIM KAPI KANAT / S-624 OUT SIDE DOOR SASH
900.S07.12 900.S07.15 900.S07.20		1.20 mm 1.50 mm 2.00 mm	0,433 0,530 0,675	S-623 SÜRME KASA / S-623 SIDING FRAME S-623 SÜRME SABÝT KASA / S-623 SIDING FIXED FRAME
900.S08.12 900.S08.15 900.S08.20		1.20 mm 1.50 mm 2.00 mm	0,659 0,789 1,021	S-623 SÜRME KANAT / S-623 SIDING SASH
900.S09.12 900.S09.15 900.S09.20		1.20 mm 1.50 mm 2.00 mm	0,518 0,648 0,864	S-863 SÜRME KASA / S-863 SIDING FRAME

**Yapmak zorundaysan,
yapabilirsin**

**İstiyorsan,
en iyisini yapabilirsin...**

**You can do it if
you have to**

**If you want it,
you can do it best...**



mywin[®]

PVC Window & Door Systems